

BOTTOM VIEW

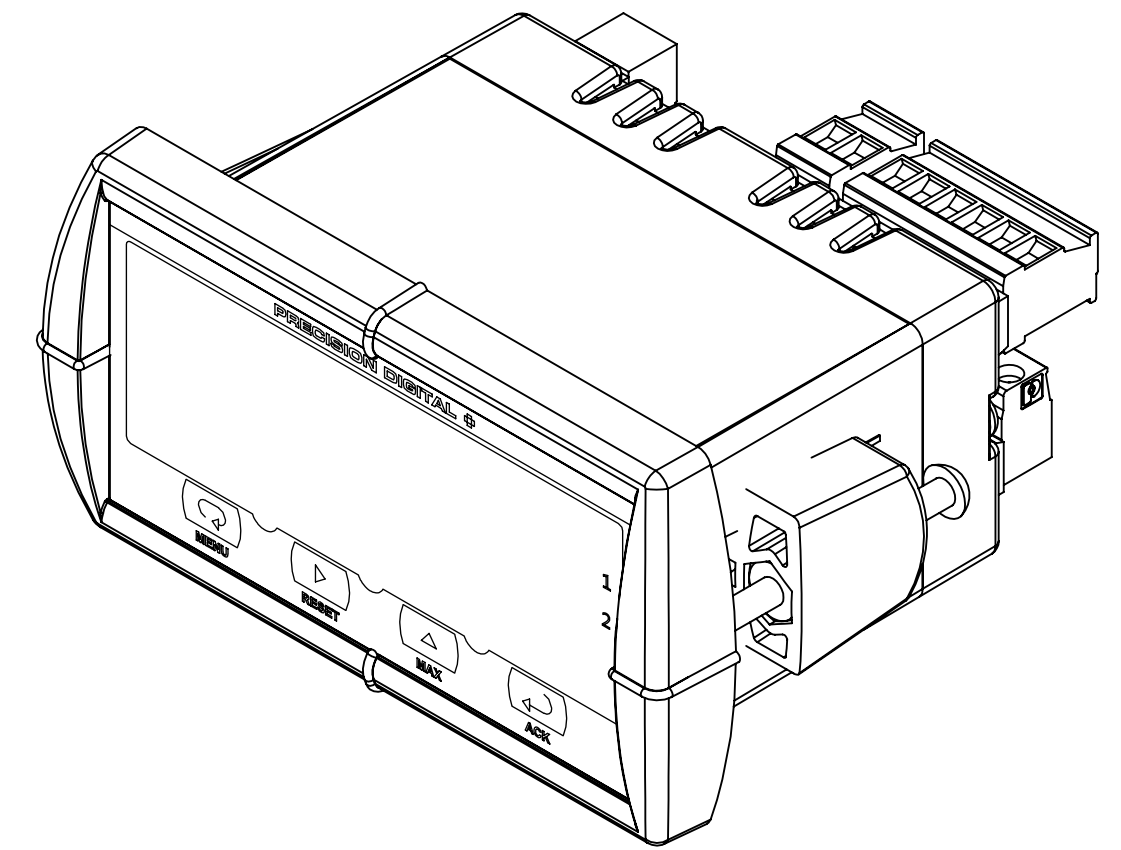

SIDE VIEW

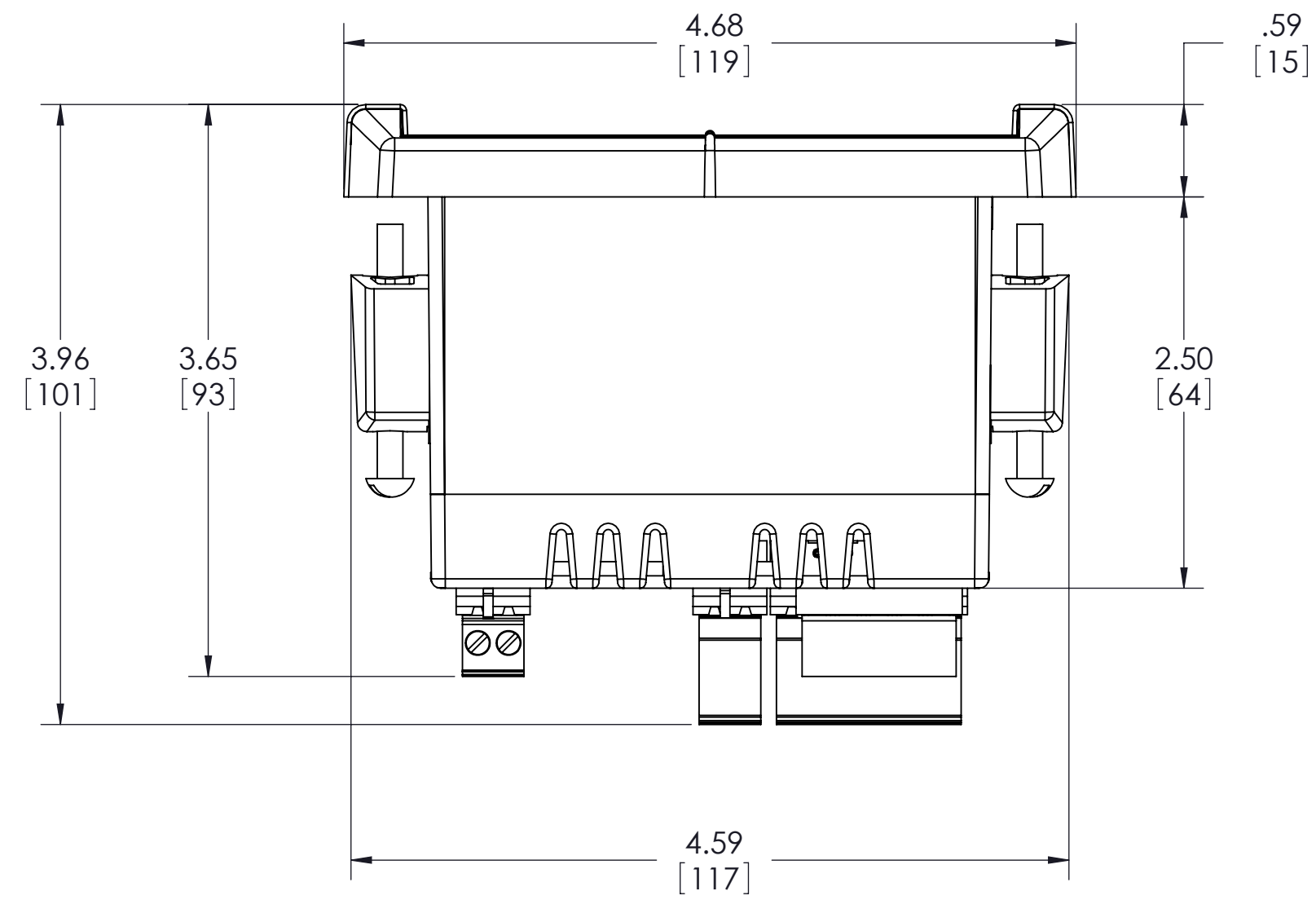
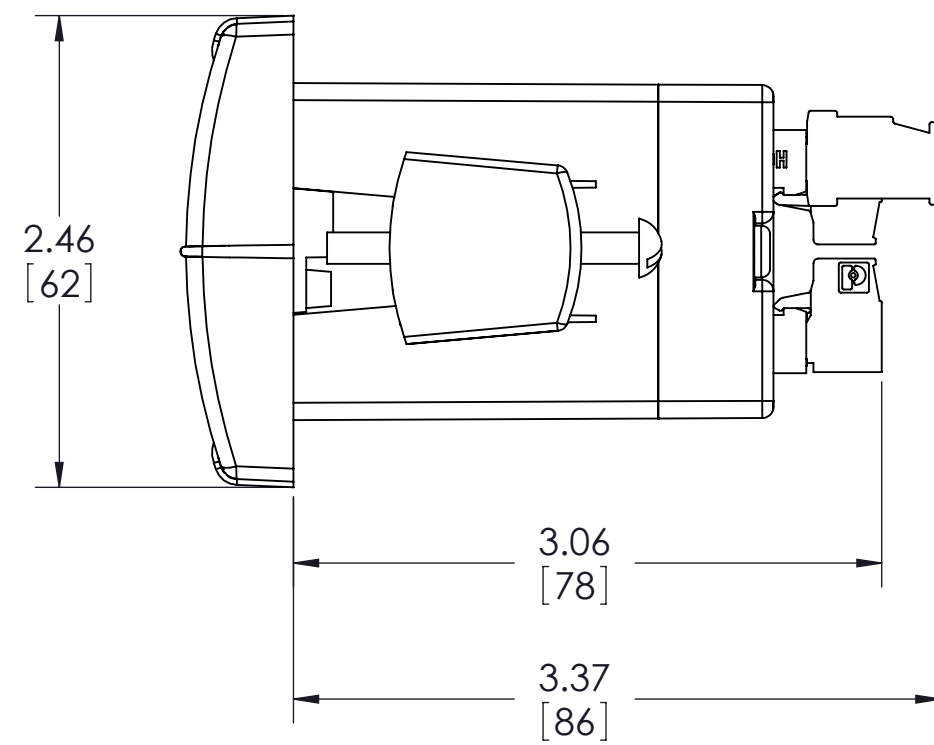

FRONT VIEW

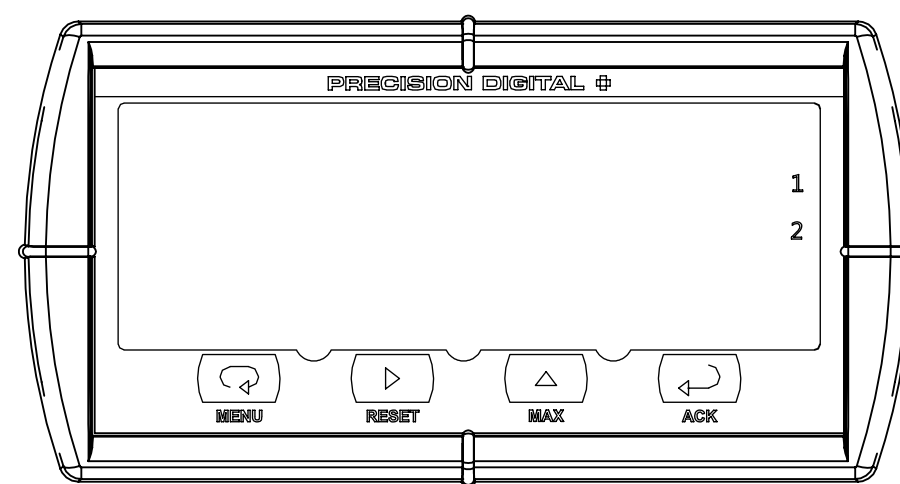

REAR VIEW

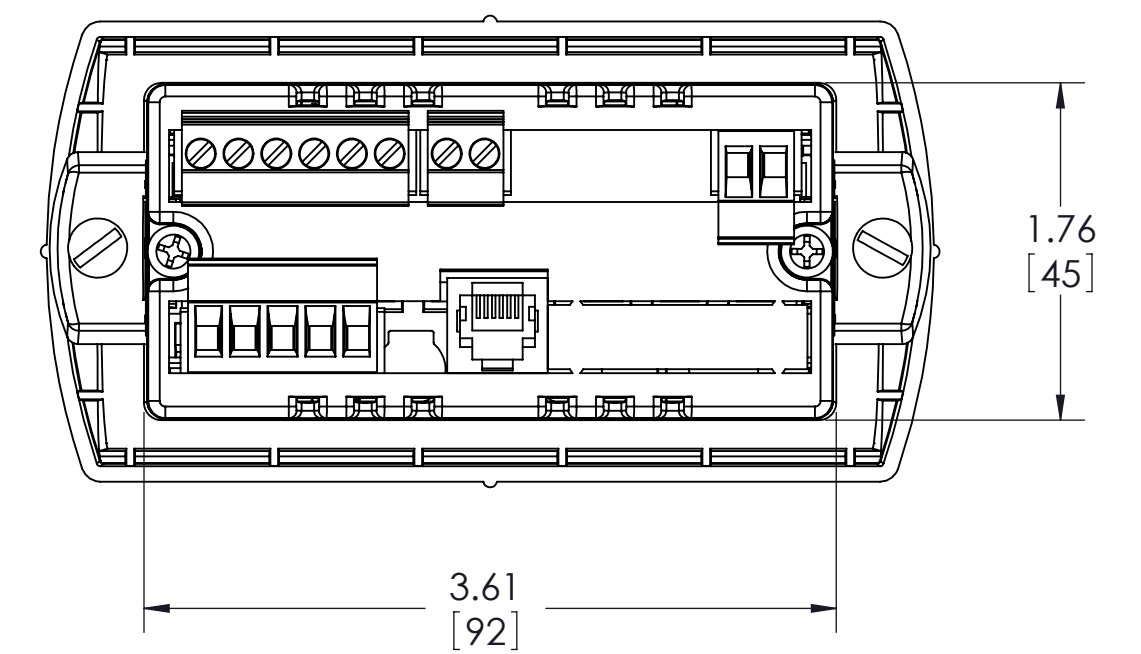

NOTES:

1. DIMENSIONS ARE IN INCHES [mm].
2. PD765-6X2-10 IS SHOWN. REAR TERMINALS MAY VARY WITH MODEL NUMBER.
3. MOUNTING BRACKETS ARE REPRESENTATIVE ONLY, SIZE AND LOCATION MAY VARY BY INSTALLATION.
4. INTERNAL ELECTRONICS AND MOUNTING GASKET NOT SHOWN.
5. RECOMMENDED 1/8 DIN INSTALLATION CUTOUT SIZE OF 3.622" x 1.772" (92 mm x 45 mm) (W x H).
6. ALLOW AT LEAST 4" BEHIND PANEL FOR WIRING.
7. PANEL THICKNESS 0.04" - 0.25" (1.0 mm - 6.4 mm).
8. RECOMMENDED MINIMUM PANEL THICKNESS TO MAINTAIN TYPE 4X:
0.06" (1.5 mm) STEEL PANEL
0.16" (4.1 mm) PLASTIC PANEL

PRECISION DIGITAL CORPORATION
HOLLISTON, MASSACHUSETTS 01746

DRAWN
M. Andrews
06/10/2013

TRIDENT X2 SERIES
METER ASSEMBLY