

PD6938 Ex-Proof & I.S. Pulse Input Flow Rate/Totalizer

Instruction Manual



ProtEX+

UL LISTED SP Ex IECEx CE

CAP TOUCH™

- Fully-Approved Explosion-Proof & Intrinsically Safe Pulse Input Flow Rate/Totalizers
- NPN Open Collector, PNP, TTL, Switch Contact, Sine Wave (Magnetic Pickup Coil), or Active Square Wave Inputs
- Top Display: Five 12-Segment Alphanumeric Characters, 0.7" (17.8 mm)
- Bottom Display: Eight 14-Segment Alphanumeric Characters, 0.4" (10.2 mm)
- Display Mountable at 0°, 90°, 180°, & 270° (No Tools Required)
- CapTouch Through-Glass Button Programming with Normal and Delayed Modes
- Red Backlight for Alarm Conditions, Enable and Disable Backlight from Menu
- 8-Digit Total & Grand Total Display, Up to 13 Digits Using Both Lines
- Display Rate & Total Simultaneously
- Bi-Directional Flow Detection Via Digital Input
- Non-Resettable Grand Total
- Display Previous Total and Previous Grand Total with Time-of-Day Reset Feature
- Reset Total / Grand Total with CapTouch Button, Digital Input, or Time-of-Day Feature
- Automatic or Manual Batch Control
- K-Factor Calibration or Scaling with Up to 32-Point Linearization
- Gate Function for Rate Display of Slow Pulse Rates
- (2) Open Collector Outputs Standard; Assignable to Pulse, Alarm, Timer, or Stopwatch
- (2) Optional Solid-State Relays; Assignable to Alarm, Sample, Timer, Batch Control, or Stopwatch
- Optional Isolated 4-20 mA Analog Output
- Free PC-Based MeterView XL USB Programming Software
- 9-30 VDC, Battery, or 4-20 mA Output Power Options
- Battery-Powered Momentary Backlight & Display Sleep and Off Modes to Extend Battery Life
- Modbus RTU RS-485 Communications Standard on DC & Battery Powered Models
- On-Board Data Logging of up to 2,032 Records and Modbus® Accessible Data
- Password Protection for Settings, Total & Grand Total
- UL Listed as Explosion-Proof / Dust Ignition-Proof / Flame-Proof
- CSA Certified as Explosion-Proof / Dust Ignition-Proof / Flame-Proof
- ATEX and IECEx Certified as Intrinsically Safe and Explosion-Proof
- Operating Temp Range: -40 to 75°C (-40 to 167°F)
- Installation Temp Range: -55 to 75°C (-67 to 167°F)
- Conformal Coated PCBs for Dust & Humidity Protection
- Flange for Wall or Pipe Mounting; Loop for Stainless Steel Tag; Holes for Tamper-Proof Seal
- Explosion-Proof Aluminum & Stainless Steel Enclosures with 1", 3/4", or M20 Connections
- 3-Year Warranty

PRECISION DIGITAL CORPORATION

233 South Street • Hopkinton MA 01748 USA
Tel (800) 343-1001 • (508) 655-7300

www.predig.com

**PRECISION
DIGITAL**

The Complete PD6900 Series

VantageView+

Plastic Enclosures - General Purpose



PD6907-GP-PL
4-20 mA Input
Feet & Inches Meter



PD6908-GP-PL
4-20 mA Input
Process Meter



PD6928-GP-PL
4-20 mA Input
Flow Rate/Totalizer



PD6938-GP-PL
Pulse Input
Flow Rate/Totalizer



Aluminum Enclosures - Hazardous Area Approved



PD6907-HA-AL
4-20 mA Input
Feet & Inches Meter



PD6908-HA-AL
4-20 mA Input
Process Meter



PD6928-HA-AL
4-20 mA Input
Flow Rate/Totalizer



PD6938-XX-AL
Pulse Input
Flow Rate/Totalizer

Stainless Steel Enclosures - Hazardous Area Approved



PD6907-HA-SS
4-20 mA Input
Feet & Inches Meter



PD6908-HA-SS
4-20 mA Input
Process Meter



PD6928-HA-SS
4-20 mA Input
Flow Rate/Totalizer



PD6938-XX-SS
Pulse Input
Flow Rate/Totalizer

Table of Contents

- Introduction..... 6**
- Key Features 7**
- Ordering Information..... 13**
 - HA Models (Dual Hazardous Approved) 13
 - IS Models (Intrinsically Safe Approved) 14
 - EX Models (Explosion-Proof Approved) 15
 - Accessories 17
- Specifications 19**
 - Display 19
 - General..... 19
 - Battery..... 20**
 - IS Models (Options: P & R) 3xAA-Cell 20
 - EX Models (Options: A & M) A-Size 20
 - EX Models (Options: B & N) C-Size..... 20
 - Battery Life with Modbus Continuously On 20
 - Enclosure..... 20**
 - Pulse Input..... 21**
 - Rate/Totalizer..... 21**
 - Batch Control 21**
 - Common Open Collector & Relay Specifications..... 22**
 - Open Collector Outputs..... 22**
 - Solid-State Relays..... 22**
 - 4-20 mA Transmitter Output..... 22**
 - On-Board Digital Input..... 22**
 - Serial Communications 23**
 - MeterView XL Software..... 23**
- General Compliance Information 23**
 - Electromagnetic Compatibility..... 23**
- Hazardous Area Approvals..... 24**
 - HA Models (Dual Hazardous Approved) 24
 - IS Models (Intrinsically Safe Approved) 24
 - EX Models (Explosion-Proof Approved) 24
- EU Declaration of Conformity..... 26**
- Safety Information 26**
- Installation..... 26**
 - Unpacking..... 26
- Mounting 27**
 - Dimensions..... 27
 - Cover Jam Screw 27
- Connections..... 28**
 - Display & Options Modules..... 28
 - Connectors Labeling..... 29**
 - DC Powered Models (-D Option) 29
 - DC Powered with Battery Backup Models (-A, -B, -P Options) 31
 - Loop Output Powered Models (-C Option)..... 33
 - Loop Output Powered with Battery Backup Models (-R, -M, -N Options)... 34
- Wiring Diagrams 35**
 - Intrinsically Safe Wiring (-HA and -IS Models)..... 35**
 - I/O Parameter Table 35
 - Explosion-Proof Wiring (-HA and -EX Models) 36**
 - Pulse Input Connections 36
 - DC Power Connections..... 37
 - Digital Input Connections 37
 - RS-485 Serial Connections..... 37
 - 4-20 mA Output Connections..... 38
 - Solid-State Relay Connections 38
 - Open Collector Output Connections 38
 - Battery Replacement..... 39**
- Setup and Programming..... 40**

- Overview** 40
- CapTouch Buttons** 40
 - CapTouch Buttons Delay 40
 - Turning Off CapTouch Buttons 40
 - CapTouch Button Tips & Troubleshooting 40
- MeterView XL Programming Software**..... 41
- CapTouch Buttons and Status Indicators**..... 42
- Display Functions & Messages**..... 43
- Main Menu**..... 47
 - Setting Numeric Values 48
- Entering the K-Factor (KFACTOR)**..... 49
- Scaling the Pulse Input (SCALE)** 50
 - Available Engineering Units 51
 - Volume Units..... 51
 - Setting Custom Units (CUSTOM)..... 52
- Setting the Display Features (DISPLAY)** 52
 - Changing the Engineering Units (UNITS)..... 52
 - Changing the Decimal Point (DECP) 52
 - Enabling or Disabling Commas on the Bottom Display (COMMA) 53
 - Display Capabilities Optimization (TOP and BOTTOM)..... 53
 - Using 13 Digits to Display Total 53
 - Configuring the Display (TOP and BOTTOM)..... 54
 - Programming the Bargraph (BARGRAPH)..... 55
- Programming the Outputs (OUTPUT)** 55
 - Open Collector Outputs (OPEN COLLECTR) 56
 - Solid-State Relay Outputs (RELAY) 61
 - Isolated 4-20 mA Output (4-20 mA) 68
 - Output Manual Control (CONTROL) 68
- Advanced Features Menu (ADVANCE)**..... 69
 - Advanced Rate Setup (ADV RATE) 69
 - Advanced Total and Grand Total Setup (ADV TOTAL & ADV GTOTAL) ... 72
 - Low-Flow Cutoff (CUTOFF) 74
 - Gate Function (GATE) 74
 - Contact Debounce Filter (FILTER)..... 74
 - Enabling Password Protection (PASSWORD) 76
 - Data Log Menu (DATALOG) 77
 - Serial Communications (COMM)..... 80
 - Programmable Function Keys User Menu (USER) 80
 - Changing System Settings (SYSTEM) 83
- Meter Operation**..... 84
 - CapTouch Buttons Operation** 84
 - CapTouch Buttons** 84
 - Function Keys Operation**..... 85
 - Digital Input Operation**..... 85
 - Maximum/Minimum Readings**..... 85
 - Total Reset Capabilities**..... 85
 - Total Reset via Digital Input 85
 - Total Reset Password Protection 85
 - Runtime & Cycle Count (INFO)**..... 86
 - Changing Engineering Units** 86
- Batch Controller Operation**..... 87
 - Default Batch Control Operation**..... 87
 - Batch Control Operation Example** 87
 - Manual Batch Control** 90
 - Automatic Batch Control** 91
- Troubleshooting** 92
 - Reset Meter to Factory Defaults**..... 92
 - Determining Software Version** 92
 - Factory Default Settings..... 93
 - Troubleshooting Tips**..... 94

Table of Figures

Figure 1. Enclosure Dimensions – Front View.....	27
Figure 2. Enclosure Dimensions – Side View	27
Figure 3. Enclosure Dimensions – Bottom View	27
Figure 4. Connector Labeling for PD6938-##-##-DNM.....	29
Figure 5. Connector Labeling for PD6938-##-##-D2M	29
Figure 6. Connector Labeling for PD6938-##-##-D3M	30
Figure 7. Connector Labeling for PD6938-##-##-D5M	30
Figure 8. Connector Labeling for PD6938-##-##-ANM, -BNM, -PNM	31
Figure 9. Connector Labeling for PD6938-##-##-A2M, -B2M, -P2M	31
Figure 10. Connector Labeling for PD6938-##-##-A3M, -B3M, -P3M	32
Figure 11. Connector Labeling for PD6938-##-##-A5M, -B5M, -P5M	32
Figure 12. Connector Labeling for PD6938-##-##-C3N.....	33
Figure 13. Connector Labeling for PD6938-##-##-C5N.....	33
Figure 14. Connector Labeling for PD6938-##-##-R3N, -M3N, -N3N.....	34
Figure 15. Connector Labeling for PD6938-##-##-R5N, -M5N, -N5N.....	34
Figure 16. Flowmeter Powered by External Supply (Active).....	36
Figure 17. Flowmeter Powered by Internal Sensor Power (5 V @ 5 mA)	36
Figure 18. Self-Powered Magnetic Pickup Flowmeter (Coil).....	36
Figure 19. Bi-Directional Flowmeter Connections.....	36
Figure 20. NPN Open Collector Input.....	36
Figure 21. PNP Sensor with External Power	36
Figure 22. Switch Contact Input (Reed).....	36
Figure 23. DC Power Connections	37
Figure 24. Digital Input Connections	37
Figure 25. RS-485 2-Wire & Ground Serial Connections.....	37
Figure 26. RS-485 4-Wire & Ground Serial Connections.....	37
Figure 27. 4-20 mA Output Connections	38
Figure 28. Solid-State Relay Connections.....	38
Figure 29. Open Collector Output Connections.....	38
Figure 30. Battery Operation	39

Disclaimer

The information contained in this document is subject to change without notice. Precision Digital Corporation makes no representations or warranties with respect to the contents hereof; and specifically disclaims any implied warranties of merchantability or fitness for a particular purpose.

CAUTION

- Read complete instructions prior to installation and operation of the meter.

WARNINGS

- This product is not recommended for life support applications or applications where malfunctioning could result in personal injury or property loss. Anyone using this product for such applications does so at his/her own risk. Precision Digital Corporation shall not be held liable for damages resulting from such improper use.
- Failure to follow installation guidelines could result in death or serious injury. Make sure only qualified personnel perform the installation.

WARNING

Cancer and Reproductive Harm - www.P65Warnings.ca.gov

Limited Warranty

Precision Digital Corporation warrants this product against defects in material or workmanship for the specified period under "Specifications" from the date of shipment from the factory. Precision Digital's liability under this limited warranty shall not exceed the purchase value, repair, or replacement of the defective unit. See Warranty Information and Terms & Conditions on www.prediq.com for complete details.

Registered Trademarks

All trademarks mentioned in this document are the property of their respective owners.

© 2024 Precision Digital Corporation.
All rights reserved.

Introduction

The PD6938 ProtEX+ pulse input flow rate/totalizers can be installed in a variety of areas (hazardous, dirty, wet, corrosive, hot, or cold) to provide convenient and informative display of flow rate and total from any pulse output flowmeter. These instruments will accept a variety of pulse inputs, including slow pulse rates. They can be powered from a battery, 9-30 VDC, or the 4-20 mA output loop, have on-board datalogging capabilities, are available with explosion-proof and intrinsically safe approvals, and can be ordered with optional 4-20 mA output and two relays.

The PD6938, with the addition of its two optional relays, can also be used as a simple batch controller.

The PD6938-IS is ATEX and IECEx Certified as Intrinsically Safe. It can operate down to -40°C and is certified by the agencies to be installed in areas that get as cold as -55°C. The display will cease functioning below -40°C but no damage will be done to the instrument.

One of the most convenient features of these instruments is their dual-line display, which is typically used to display the flow rate on the top display and flow total, flow grand total, or a tag on the bottom display. The top display has five characters and the bottom display has eight characters for clear indication of tags, units, or alarm messages. Further enhancing the display on these instruments is a 20-segment bargraph and backlighting that can turn red during an alarm condition.

The PD6938 ProtEX+ is available in aluminum and stainless steel enclosures that are designed for easy use and installation. The process connection is available in M20, 3/4" NPT and 1" NPT and there are two other conduit holes for field wiring. Field wiring is made to removable screw terminals and the display module can be oriented in 4 different positions to accommodate different mounting configurations and requires no tools to install. The display has been designed to optimize viewing angle.

Free, PC-based, [MeterView XL software](#) that connects to the meter via a micro-USB cable is available for programming and setup of the instruments. Four CapTouch through-glass buttons are available to operate the instrument without removing the cover.

All models come equipped with two open collector outputs and a digital input. There are also models available with Modbus RTU RS-485 communications, two solid-state relays, and isolated 4-20 mA analog output options. The open collector outputs are useful for alarm indication or pulse output. The digital input can be used to reset the total, to start/stop a timer/stopwatch, to start/stop a batch, and more. The relays can be programmed for alarm indication, on/off control, or simple batch control.

Key Features

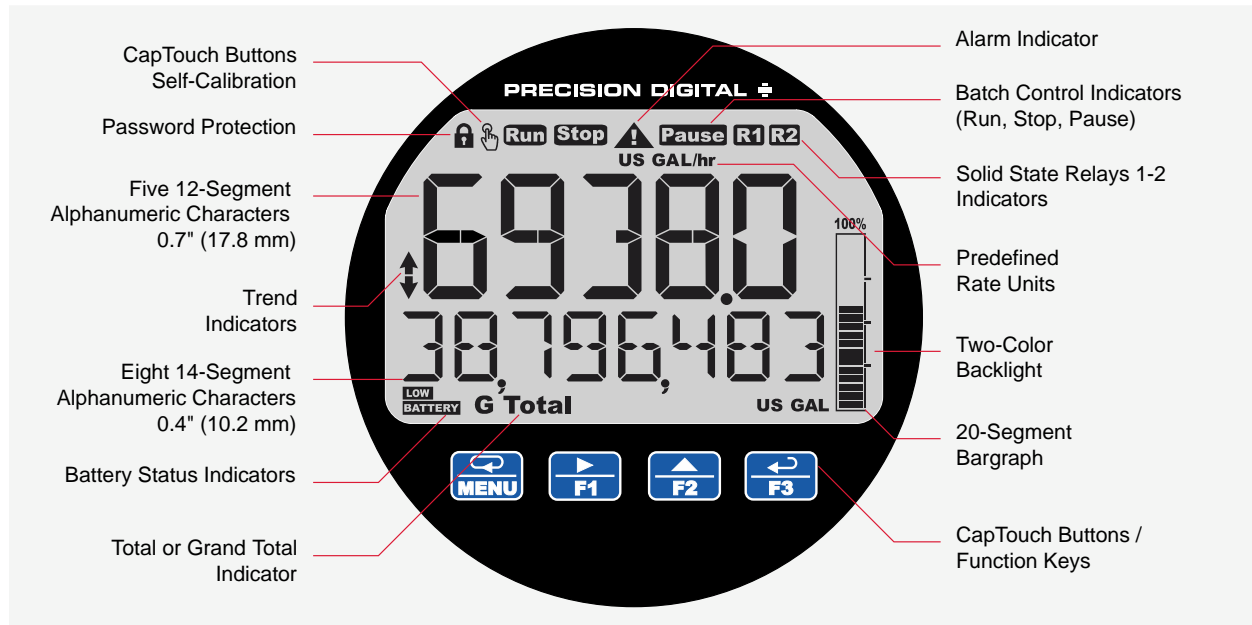

2X More Informative Display

The PD6938 display offers a 50% larger display area and is twice more informative than previous generations of pulse input meters. Featuring an alphanumeric dual-line display and a 20-segment bargraph, reading and understanding process values is easy and intuitive. The addition of status indicators provides a quick glance at alarm conditions, relays, process trends, and more. Predefined display units give users even more display flexibility. Plus, the high contrast backlit LCD display is readable from far away and under various lighting conditions.

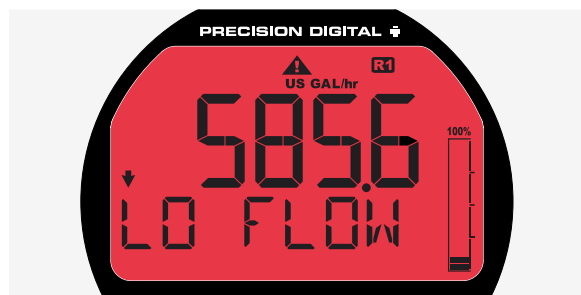

Alarm Indication

When an alarm occurs, the display can be programmed to turn red, flash, and display an alarm indicator . In addition, a unique custom alarm message for each of the two relays and two open collectors can be displayed on the bottom display. These features can be activated even if no relay or open collector is connected.

CapTouch Through-Glass Buttons

The PD6938 is equipped with four capacitive sensors that operate as through-glass buttons so that it can be operated without removing the cover (and exposing the electronics) in a hazardous area. CapTouch buttons are designed to work under any lighting condition and to protect against false triggering. They can be turned off for security via a switch on the display module.



CapTouch buttons have two modes of operation: Normal and Delayed. Delayed mode prevents accidental trigger of the buttons. In the Delayed mode, the buttons enter into a low sensitivity state (sleep) and they ignore quick button presses after 20 seconds of inactivity. To wake up the buttons, press and hold any button for more than 2 seconds, the buttons respond normally.

Commas on 8-Digit Totalizer for Easy Reading

It may seem like a simple thing, but adding commas to an eight-digit number makes it easier to read:

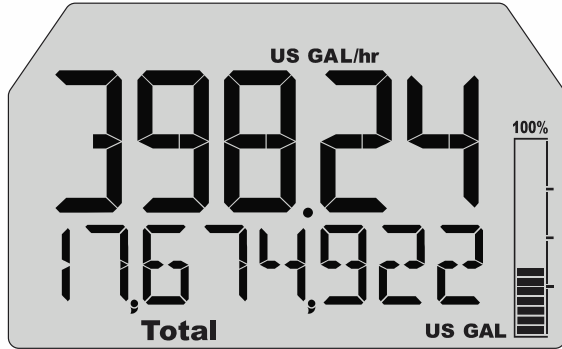

Predefined and Custom Units

The PD6938 flow rate/totalizer has the most common predefined rate and volume units. If the desired unit is not available, the user can program a custom unit.

14-Segment Characters

Notice how much better letters like “T”, “N” and “K” appear as 14-segment characters on the bottom display vs. 7-segment characters found on other meters.



Enable / Disable Backlight

The backlight may be enabled or disabled using the System - Backlight menu. The backlight is enabled by default, and it is set up to timeout after 10 seconds when battery power is used. See *Enabling or Disabling the Backlight (BACKLITE)* on page 83 for details.

Multiple Outputs

- Two open collector outputs (standard)
- Two solid-state relays **31** **32** (optional)
- One 4-20 mA output (optional)

The open collector outputs and relays generally operate in the same manner, with the major exception being the open collectors are not available for batch control and the relays are not available with pulse features. The open collectors and relays can be controlled either automatically or manually.

The isolated analog output signal can be configured to represent the process variable (flow rate, total, or retransmit). It can also be reverse scaled such that the meter’s high calibration value outputs 4 mA and the meter’s low calibration outputs 20 mA.

Password Protection

A password can be set up for programming security to prevent unauthorized changes to the programmed parameter settings.



Free MeterView XL Programming Software

The fastest and easiest way to program the meter is using the free MeterView XL programming software. This software greatly simplifies the programming process and allows the user to save configuration files for later use.

The meter connects to the PC via a provided micro-USB cable and is powered by the USB connection, so no additional power is needed during programming.



Easy Wiring & Service

The PD6938 has been designed for easy wiring and servicing. All connections are made to removable screw terminal blocks. There are no exposed printed circuit boards.



Wide Viewing Angle

The window and display module have been optimized to provide a wide viewing angle of approximately ±40°; nearly twice that of the competition.

Modern and Practical Enclosure

The PD6938 NEMA 4X, IP68 enclosure provides serious protection from the elements, high impact, corrosion, and electrical interference. Plus, the extensive worldwide agency approvals allow it to be installed virtually anywhere.



Aluminum or Stainless Steel Enclosure

The enclosure is available in copper-free (0.3%), die-cast aluminum and type 316 stainless steel.



Direct Mounting

The PD6938 features a bottom threaded conduit opening available in M20, 3/4" NPT and 1" NPT, which allows easy mounting directly to a flowmeter. This image shows a battery powered PD6938 mounted to a turbine flowmeter. Even though it is battery powered, it has a backlight that turns on only when CapTouch buttons are in use.



Built-In Flange for Pipe Mounting

The built-in mounting flange allows easy mounting to walls or pipes.



A slot on the back makes it easy to center the unit on a pipe.



Grounding Screw

A grounding screw is provided on the bottom of the enclosure.



SS Tag Attaching Loop

The enclosure is also equipped with a loop to easily attach a PDA-SSTAG stainless steel tag.



Tamper-Proof Capability

The instrument can be made tamper-proof by inserting a wire through the built-in loop on the base of the enclosure and a hole in the lid in the enclosure and securing this wire with a lead seal.

Rate/Totalizer Features

Display Flow Rate & Total at the Same Time

The PD6938 can display flow rate and total at the same time. In addition, the meter can toggle between the rate and total and their corresponding units as the following example illustrates.

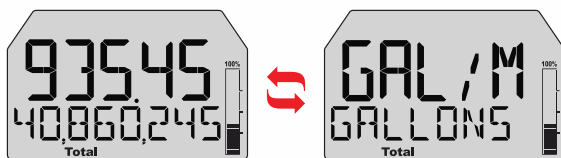

Total Limit & Initial Value

The *Advanced – Total Count* menu allows the digit limit to be selected between 8-digit (bottom display only) and 13-digit (uses top and bottom display to display the full number).

The user can set the initial value at which the total and grand total should start counting.

Using 13 Digits to Display Total

The top and bottom displays can be set up to display a 13-digit total.

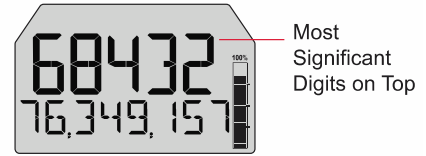

Note: The number above should be read as 6,843,276,349,187

Total & Rate in Different Units

The user can select to display total in different units than the rate. For instance, a customer could measure flow rate in gallons per minute and total in acre-feet by simply selecting AF (acre-feet) units for the total. Additionally the user can enter a custom unit and conversion factor to display the total in any unit of measure.

Rate in Units Per Second, Minute, Hour, or Day

The user may select a rate time base in units per second, minute, hour, or day. The time base is the amount of time over which the rate parameter will totalize. For example, if the rate was 10 gallons/min (and stayed constant for one minute), then the total would increase by 10 every minute.

4-20 mA Output for Rate or Total

The 4-20 mA output can be assigned to the rate or the total.

Total Stored in Non-Volatile Memory

Total and grand total values, and all programmed settings are stored in non-volatile memory for a minimum of ten years if power is lost.

Total Reset Capabilities

The total and grand total can be reset using a CapTouch button, an external contact closure on the digital input, or MeterView XL software. In addition, both total and grand total reset can be password protected to prevent unauthorized resets.

Time of Day Total Reset

The total and grand total can be set up to reset at a time of day every day or any day of the week. The previous total and grand total are saved prior to applying the reset command. The previous totals can be read via the F1 function key and the Modbus registers.

There are four reset times that can be set up, all choices allow specifying the reset day and time.

Total Reset via CapTouch Button

The CapTouch function key F2 is set up to reset the total. If reset grand total is enabled, it is possible for the user to reset either the total or the grand total without removing the cover or the need for external devices.



Total Reset via Digital Input

The PD6938's digital input can also be used to reset the total or grand total.

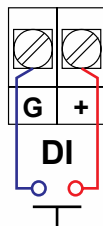

Total Reset Password Protection

Total and grand total passwords can be set to prevent resetting the total or grand total unless a password is entered. Grand total reset can be disabled through the meter interface, and it can also be permanently disabled.

Non-Resettable Grand Total

The user can set up the grand total to be non-resettable by selecting YES at the PERMLOC menu; see page 73 for details. Once this is done, the grand total can never be reset.

Batch Control Capabilities

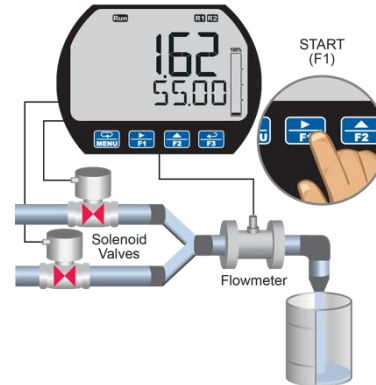

The meter can be equipped with two solid-state relays that may be set up for batch control. Selecting batch control for relay 1 enables the batching features on the meter. The top display changes to show the total and the bottom display changes to show the batch preset. The function keys also change for batch control functions such as F1 starts a batch, F2 opens the preset menu to allow the preset value to be changed, and F3 stops the currently running batch. Enabling batch control for relay 1 allows access to the batch menu under relay 2. The second relay may be programmed as a preclose relay or as another batching relay with its own preset amount.

Manual or Automatic Operation

Batching can be set to either manual or automatic operation.

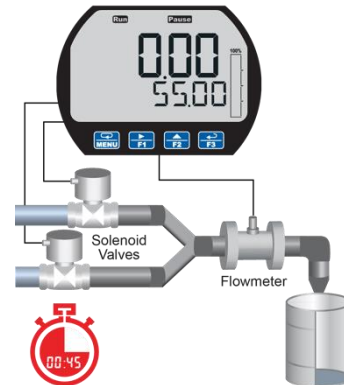

If set to automatic, then a delay before the next batch starts must be programmed.

Count Up or Down Batching

The batch total can be set to count up or down.

Data Logging

The PD6938 is capable of data logging up to 2,032 records, each containing date, time, rate, total, grand total, and relay & open collector states. The user can choose what information to log, when, and how to log it. The log file can be downloaded using the MeterView XL software and it can be saved in .csv file format.

The easiest way to set up the data logger is using the MeterView XL software connected via the micro-USB port or the RS-485 Modbus connection. There are many ways to log data using the on-board memory. Use the MeterView XL software to download the data or a Modbus application.

- Log time: Every day or any day of the week
- Log time interval: Select the logging interval
- Select to log continuously or stop when full



Data Log Example

The log file is saved in .csv file format and it contains all the information selected in the data log setup.

Meter Model	Firmware	MeterView v.1.0	Download Time	April 18 2023 10:59 AM											
Date	Time	Sequence	Source	Rate	Units	Total	Grand Total	OC1	OC2	Relay1	Relay2				
4	Apr/18/2023	10:17:57	1	OC1	100	GAL/sec	6053	GAL	6053	GAL	Alarm On	Alarm On	On	Off	
5	Apr/18/2023	10:17:57	1	OC2	100	GAL/sec	6053	GAL	6053	GAL	Alarm On	Alarm On	On	Off	
6	Apr/18/2023	10:17:57	1	Rly1	100	GAL/sec	6053	GAL	6053	GAL	Alarm On	Alarm On	On	Off	
7	Apr/18/2023	10:18:00	2	Interval	100	GAL/sec	6353	GAL	6353	GAL	Alarm On	Alarm On	On	Off	
8	Apr/18/2023	10:18:07	3	Rly1	44	GAL/sec	6579	GAL	6579	GAL	Alarm On	Alarm On	On	Off	
9	Apr/18/2023	10:18:09	4	OC1	25	GAL/sec	7028	GAL	7028	GAL	Alarm On	OC2 Off	Off	Off	
10	Apr/18/2023	10:18:12	5	OC1	10	GAL/sec	7067	GAL	7067	GAL	OC1 Off	OC2 Off	Off	Off	
11	Apr/18/2023	10:18:25	6	OC1	36	GAL/sec	7367	GAL	7367	GAL	Alarm On	OC2 Off	Off	Off	
12	Apr/18/2023	10:18:36	7	OC2	45	GAL/sec	7396	GAL	7396	GAL	Alarm On	Alarm On	Off	Off	
13	Apr/18/2023	10:18:47	8	Rly1	60	GAL/sec	8022	GAL	8022	GAL	Alarm On	Alarm On	On	On	
14	Apr/18/2023	10:18:47	9	Rly2	60	GAL/sec	8022	GAL	8022	GAL	Alarm On	Alarm On	On	On	
15	Apr/18/2023	10:18:57	9	Rly1	60	GAL/sec	8622	GAL	8622	GAL	Alarm On	Alarm On	Off	Off	
16	Apr/18/2023	10:18:57	9	Rly2	60	GAL/sec	8622	GAL	8622	GAL	Alarm On	Alarm On	Off	Off	
17	Apr/18/2023	10:19:00	10	Interval	60	GAL/sec	8902	GAL	8902	GAL	Alarm On	Alarm On	Off	Off	
18	Apr/18/2023	10:19:21	11	Rly1	60	GAL/sec	10062	GAL	10062	GAL	Alarm On	Alarm On	On	On	
19	Apr/18/2023	10:19:31	12	Rly1	60	GAL/sec	10662	GAL	10662	GAL	Alarm On	Alarm On	On	On	
20	Apr/18/2023	10:19:54	13	Rly1	60	GAL/sec	12041	GAL	12041	GAL	Alarm On	Alarm On	On	On	
21	Apr/18/2023	10:19:54	13	Rly2	60	GAL/sec	12041	GAL	12041	GAL	Alarm On	Alarm On	On	On	
22	Apr/18/2023	10:20:00	14	Interval	60	GAL/sec	12481	GAL	12481	GAL	Alarm On	Alarm On	On	On	
23	Apr/18/2023	10:20:04	15	Rly1	60	GAL/sec	12941	GAL	12941	GAL	Alarm On	Alarm On	Off	Off	
24	Apr/18/2023	10:20:04	15	Rly2	60	GAL/sec	12941	GAL	12941	GAL	Alarm On	Alarm On	Off	Off	
25	Apr/18/2023	10:20:27	16	Rly1	60	GAL/sec	14021	GAL	14021	GAL	Alarm On	Alarm On	On	On	
26	Apr/18/2023	10:20:37	17	Rly1	60	GAL/sec	14621	GAL	14621	GAL	Alarm On	Alarm On	Off	Off	
27	Apr/18/2023	10:21:00	18	Interval	60	GAL/sec	15801	GAL	15801	GAL	Alarm On	Alarm On	On	On	
28	Apr/18/2023	10:21:01	19	Rly1	60	GAL/sec	16061	GAL	16061	GAL	Alarm On	Alarm On	On	On	
29	Apr/18/2023	10:21:01	19	Rly2	60	GAL/sec	16061	GAL	16061	GAL	Alarm On	Alarm On	On	On	
30	Apr/18/2023	10:21:11	20	Rly1	60	GAL/sec	16661	GAL	16661	GAL	Alarm On	Alarm On	On	On	
31	Apr/18/2023	10:21:11	20	Rly2	60	GAL/sec	16661	GAL	16661	GAL	Alarm On	Alarm On	On	On	
32	Apr/18/2023	10:21:34	21	Rly1	60	GAL/sec	18041	GAL	18041	GAL	Alarm On	Alarm On	On	On	
33	Apr/18/2023	10:21:44	22	Rly1	60	GAL/sec	18641	GAL	18641	GAL	Alarm On	Alarm On	Off	Off	
34	Apr/18/2023	10:21:50	23	Interval	60	GAL/sec	19601	GAL	19601	GAL	Alarm On	Alarm On	Off	Off	
35	Apr/18/2023	10:22:07	24	Rly1	60	GAL/sec	20021	GAL	20021	GAL	Alarm On	Alarm On	On	On	
36	Apr/18/2023	10:22:07	24	Rly2	60	GAL/sec	20021	GAL	20021	GAL	Alarm On	Alarm On	On	On	
37	Apr/18/2023	10:22:17	25	Rly1	60	GAL/sec	20621	GAL	20621	GAL	Alarm On	Alarm On	Off	Off	

Power Options

The PD6938 offers a wide range of power options including battery, DC with battery backup, DC only, output loop, or output loop with battery backup. See Specifications for details on each of the power options available. See Ordering Information for details on what power options are available for each hazardous area approval.

Battery Backup

Select models are available with a battery backup power option. For these models, the primary power source is supplied by either DC power or the output loop, depending on the model. The battery is used during battery backup operation. If there is a power failure of the primary power source, the battery will instantly take over powering the meter. There will be no display interruption nor any information loss.

Battery Status Indication

Battery indicators on the display alert users of the power status of the PD6938.

Indicator	State	Description
BATTERY	Flashing	Meter checking battery status
	Steady	Meter using battery power
LOW BATTERY	Flashing	Low battery

Designed for Long Battery Life

The PD6938 is designed with power savings in mind to help extend battery life.

LCD Sleep Mode

LCD sleep mode turns the LCD off after a user programmable amount of time, while all inputs and outputs continue working. Press any button for 2 seconds to wake up the display.

CapTouch Delayed Mode

In Delayed mode, the buttons enter into a low sensitivity state (sleep) after 20 seconds of inactivity. Press any button for 2 seconds to wake up the buttons.

Momentary Backlight

The backlight is enabled by default. If the meter is battery powered, then the backlight is automatically set up to momentarily turn on for 10 seconds when any button is pressed.

Turn Meter Off

To extend battery life even more, the meter can be turned off completely when it is not in use. Press and hold the Menu button for 5 seconds to turn the meter on or off and follow the on-screen instructions.

Ordering Information

-HA Models (Dual Hazardous Approved)

Aluminum Enclosure

Loop Output Powered ⁶	
Model	Description
PD6938-HA-AL-C3N	Pulse Input Explosion-Proof & Intrinsically Safe Flow Rate/Totalizer, 4-20 mA Analog Output
PD6938-HA-AL-C5N	Pulse Input Explosion-Proof & Intrinsically Safe Flow Rate/Totalizer, Two Solid-State Relays & 4-20 mA Analog Output

DC Powered ⁵	
Model	Description
PD6938-HA-AL-DNM	Pulse Input Explosion-Proof & Intrinsically Safe Flow Rate/Totalizer, No Options
PD6938-HA-AL-D2M	Pulse Input Explosion-Proof & Intrinsically Safe Flow Rate/Totalizer, Two Solid-State Relays
PD6938-HA-AL-D3M	Pulse Input Explosion-Proof & Intrinsically Safe Flow Rate/Totalizer, 4-20 mA Analog Output
PD6938-HA-AL-D5M	Pulse Input Explosion-Proof & Intrinsically Safe Flow Rate/Totalizer, Two Solid-State Relays & 4-20 mA Analog Output

Stainless Steel Enclosure

Loop Output Powered ⁶	
Model	Description
PD6938-HA-SS-C3N	Pulse Input Explosion-Proof & Intrinsically Safe Flow Rate/Totalizer, 4-20 mA Analog Output
PD6938-HA-SS-C5N	Pulse Input Explosion-Proof & Intrinsically Safe Flow Rate/Totalizer, Two Solid-State Relays & 4-20 mA Analog Output

DC Powered ⁵	
Model	Description
PD6938-HA-SS-DNM	Pulse Input Explosion-Proof & Intrinsically Safe Flow Rate/Totalizer, No Options
PD6938-HA-SS-D2M	Pulse Input Explosion-Proof & Intrinsically Safe Flow Rate/Totalizer, Two Solid-State Relays
PD6938-HA-SS-D3M	Pulse Input Explosion-Proof & Intrinsically Safe Flow Rate/Totalizer, 4-20 mA Analog Output
PD6938-HA-SS-D5M	Pulse Input Explosion-Proof & Intrinsically Safe Flow Rate/Totalizer, Two Solid-State Relays & 4-20 mA Analog Output

Notes:

- All models come with bargraph, two open collector outputs, and one digital input standard.
- The meter comes standard with three 3/4" NPT conduit holes.
- To order models with different conduit holes, add the following at the end of the part number:
 - 21 for M20 conduit holes (e.g. PD6938-HA-AL-DNM-21)
 - 24 for one 1" bottom and two 3/4" NPT conduit holes (e.g. PD6938-HA-AL-DNM-24)
- Meters with dual hazardous area approval are not available with battery power options.
- Modbus is standard on all DC powered models.
- Modbus is not available with loop-powered models.

-IS Models (Intrinsically Safe Approved)

Aluminum Enclosure

Loop Output Powered ⁶	
Model	Description
PD6938-IS-AL-C3N	Pulse Input Intrinsically Safe Flow Rate/Totalizer, 4-20 mA Analog Output
PD6938-IS-AL-C5N	Pulse Input Intrinsically Safe Flow Rate/Totalizer, Two Solid-State Relays & 4-20 mA Analog Output

DC Powered ⁵	
Model	Description
PD6938-IS-AL-DNM	Pulse Input Intrinsically Safe Flow Rate/Totalizer, No Options
PD6938-IS-AL-D2M	Pulse Input Intrinsically Safe Flow Rate/Totalizer, Two Solid-State Relays
PD6938-IS-AL-D3M	Pulse Input Intrinsically Safe Flow Rate/Totalizer, 4-20 mA Analog Output
PD6938-IS-AL-D5M	Pulse Input Intrinsically Safe Flow Rate/Totalizer, Two Solid-State Relays & 4-20 mA Analog Output

DC Powered with 3xAA Battery Pack (Primary or Backup) ⁵	
Model	Description
PD6938-IS-AL-PNM	Pulse Input Intrinsically Safe Flow Rate/Totalizer, No Options
PD6938-IS-AL-P2M	Pulse Input Intrinsically Safe Flow Rate/Totalizer, Two Solid-State Relays
PD6938-IS-AL-P3M	Pulse Input Intrinsically Safe Flow Rate/Totalizer, 4-20 mA Analog Output
PD6938-IS-AL-P5M	Pulse Input Intrinsically Safe Flow Rate/Totalizer, Two Solid-State Relays & 4-20 mA Analog Output

Loop Output Powered with 3xAA Battery Pack (Backup) ⁶	
Model	Description
PD6938-IS-AL-R3N	Pulse Input Intrinsically Safe Flow Rate/Totalizer, 4-20 mA Analog Output
PD6938-IS-AL-R5N	Pulse Input Intrinsically Safe Flow Rate/Totalizer, Two Solid-State Relays & 4-20 mA Analog Output

Stainless Steel Enclosure

Loop Output Powered ⁶	
Model	Description
PD6938-IS-SS-C3N	Pulse Input Intrinsically Safe Flow Rate/Totalizer, 4-20 mA Analog Output
PD6938-IS-SS-C5N	Pulse Input Intrinsically Safe Flow Rate/Totalizer, Two Solid-State Relays & 4-20 mA Analog Output

DC Powered ⁵	
Model	Description
PD6938-IS-SS-DNM	Pulse Input Intrinsically Safe Flow Rate/Totalizer, No Options
PD6938-IS-SS-D2M	Pulse Input Intrinsically Safe Flow Rate/Totalizer, Two Solid-State Relays
PD6938-IS-SS-D3M	Pulse Input Intrinsically Safe Flow Rate/Totalizer, 4-20 mA Analog Output
PD6938-IS-SS-D5M	Pulse Input Intrinsically Safe Flow Rate/Totalizer, Two Solid-State Relays & 4-20 mA Analog Output

DC Powered with 3xAA Battery Pack (Primary or Backup) ⁵	
Model	Description
PD6938-IS-SS-PNM	Pulse Input Intrinsically Safe Flow Rate/Totalizer, No Options
PD6938-IS-SS-P2M	Pulse Input Intrinsically Safe Flow Rate/Totalizer, Two Solid-State Relays
PD6938-IS-SS-P3M	Pulse Input Intrinsically Safe Flow Rate/Totalizer, 4-20 mA Analog Output
PD6938-IS-SS-P5M	Pulse Input Intrinsically Safe Flow Rate/Totalizer, Two Solid-State Relays & 4-20 mA Analog Output

Loop Output Powered with 3xAA Battery Pack (Backup) ⁶	
Model	Description
PD6938-IS-SS-R3N	Pulse Input Intrinsically Safe Flow Rate/Totalizer, 4-20 mA Analog Output
PD6938-IS-SS-R5N	Pulse Input Intrinsically Safe Flow Rate/Totalizer, Two Solid-State Relays & 4-20 mA Analog Output

Notes:

- All models come with bargraph, two open collector outputs, and one digital input standard.
- The meter comes standard with three 3/4" NPT conduit holes.
- To order models with different conduit holes, add the following at the end of the part number:
 - 21 for M20 conduit holes (e.g. PD6938-IS-AL-PNM-21)
 - 24 for one 1" bottom and two 3/4" NPT conduit holes (e.g. PD6938-IS-AL-PNM-24)
- Battery powered meters with Intrinsically Safe approval are available only with 3xAA battery power option.
- Modbus is standard on all DC powered models.
- Modbus is not available with loop-powered models.

-EX Models (Explosion-Proof Approved)

Aluminum Enclosure

DC Powered with A Cell Battery Pack (Primary or Backup) ⁵	
Model	Description
PD6938-EX-AL-ANM	Pulse Input Explosion-Proof Flow Rate/Totalizer, No Options
PD6938-EX-AL-A2M	Pulse Input Explosion-Proof Flow Rate/Totalizer, Two Solid-State Relays
PD6938-EX-AL-A3M	Pulse Input Explosion-Proof Flow Rate/Totalizer, 4-20 mA Analog Output
PD6938-EX-AL-A5M	Pulse Input Explosion-Proof Flow Rate/Totalizer, Two Solid-State Relays & 4-20 mA Analog Output

DC Powered with C Cell Battery Pack (Primary or Backup) ⁵	
Model	Description
PD6938-EX-AL-BNM	Pulse Input Explosion-Proof Flow Rate/Totalizer, No Options
PD6938-EX-AL-B2M	Pulse Input Explosion-Proof Flow Rate/Totalizer, Two Solid-State Relays
PD6938-EX-AL-B3M	Pulse Input Explosion-Proof Flow Rate/Totalizer, 4-20 mA Analog Output
PD6938-EX-AL-B5M	Pulse Input Explosion-Proof Flow Rate/Totalizer, Two Solid-State Relays & 4-20 mA Analog Output

Loop Output Powered ⁶	
Model	Description
PD6938-EX-AL-C3N	Pulse Input Explosion-Proof Flow Rate/Totalizer, 4-20 mA Analog Output
PD6938-EX-AL-C5N	Pulse Input Explosion-Proof Flow Rate/Totalizer, Two Solid-State Relays & 4-20 mA Analog Output

DC Powered ⁵	
Model	Description
PD6938-EX-AL-DNM	Pulse Input Explosion-Proof Flow Rate/Totalizer, No Options
PD6938-EX-AL-D2M	Pulse Input Explosion-Proof Flow Rate/Totalizer, Two Solid-State Relays
PD6938-EX-AL-D3M	Pulse Input Explosion-Proof Flow Rate/Totalizer, 4-20 mA Analog Output
PD6938-EX-AL-D5M	Pulse Input Explosion-Proof Flow Rate/Totalizer, Two Solid-State Relays & 4-20 mA Analog Output

Loop Output Powered with A Cell Battery Pack (Backup) ⁶	
Model	Description
PD6938-EX-AL-M3N	Pulse Input Explosion-Proof Flow Rate/Totalizer, 4-20 mA Analog Output
PD6938-EX-AL-M5N	Pulse Input Explosion-Proof Flow Rate/Totalizer, Two Solid-State Relays & 4-20 mA Analog Output

Loop Output Powered with C Cell Battery Pack (Backup) ⁶	
Model	Description
PD6938-EX-AL-N3N	Pulse Input Explosion-Proof Flow Rate/Totalizer, 4-20 mA Analog Output
PD6938-EX-AL-N5N	Pulse Input Explosion-Proof Flow Rate/Totalizer, Two Solid-State Relays & 4-20 mA Analog Output

Notes:

- All models come with bargraph, two open collector outputs, and one digital input standard.
- The meter comes standard with three 3/4" NPT conduit holes.
- To order models with different conduit holes, add the following at the end of the part number:
 - 21 for M20 conduit holes (e.g. PD6938-EX-AL-ANM-21)
 - 24 for one 1" bottom and two 3/4" NPT conduit holes (e.g. PD6938-EX-AL-ANM-24)
- Battery powered meters with Explosion-Proof approval are available only with A and C Cell battery power options.
- Modbus is standard on all DC powered models.
- Modbus is not available with loop-powered models.

Stainless Steel Enclosure

DC Powered with A Cell Battery Pack (Primary or Backup) ⁵	
Model	Description
PD6938-EX-SS-ANM	Pulse Input Explosion-Proof Flow Rate/Totalizer, No Options
PD6938-EX-SS-A2M	Pulse Input Explosion-Proof Flow Rate/Totalizer, Two Solid-State Relays
PD6938-EX-SS-A3M	Pulse Input Explosion-Proof Flow Rate/Totalizer, 4-20 mA Analog Output
PD6938-EX-SS-A5M	Pulse Input Explosion-Proof Flow Rate/Totalizer, Two Solid-State Relays & 4-20 mA Analog Output

DC Powered with C Cell Battery Pack (Primary or Backup) ⁵	
Model	Description
PD6938-EX-SS-BNM	Pulse Input Explosion-Proof Flow Rate/Totalizer, No Options
PD6938-EX-SS-B2M	Pulse Input Explosion-Proof Flow Rate/Totalizer, Two Solid-State Relays
PD6938-EX-SS-B3M	Pulse Input Explosion-Proof Flow Rate/Totalizer, 4-20 mA Analog Output
PD6938-EX-SS-B5M	Pulse Input Explosion-Proof Flow Rate/Totalizer, Two Solid-State Relays & 4-20 mA Analog Output

Loop Output Powered ⁶	
Model	Description
PD6938-EX-SS-C3N	Pulse Input Explosion-Proof Flow Rate/Totalizer, 4-20 mA Analog Output
PD6938-EX-SS-C5N	Pulse Input Explosion-Proof Flow Rate/Totalizer, Two Solid-State Relays & 4-20 mA Analog Output

DC Powered ⁵	
Model	Description
PD6938-EX-SS-DNM	Pulse Input Explosion-Proof Flow Rate/Totalizer, No Options
PD6938-EX-SS-D2M	Pulse Input Explosion-Proof Flow Rate/Totalizer, Two Solid-State Relays
PD6938-EX-SS-D3M	Pulse Input Explosion-Proof Flow Rate/Totalizer, 4-20 mA Analog Output
PD6938-EX-SS-D5M	Pulse Input Explosion-Proof Flow Rate/Totalizer, Two Solid-State Relays & 4-20 mA Analog Output

Loop Output Powered with A Cell Battery Pack (Backup) ⁶	
Model	Description
PD6938-EX-SS-M3N	Pulse Input Explosion-Proof Flow Rate/Totalizer, 4-20 mA Analog Output
PD6938-EX-SS-M5N	Pulse Input Explosion-Proof Flow Rate/Totalizer, Two Solid-State Relays & 4-20 mA Analog Output

Loop Output Powered with C Cell Battery Pack (Backup) ⁶	
Model	Description
PD6938-EX-SS-N3N	Pulse Input Explosion-Proof Flow Rate/Totalizer, 4-20 mA Analog Output
PD6938-EX-SS-N5N	Pulse Input Explosion-Proof Flow Rate/Totalizer, Two Solid-State Relays & 4-20 mA Analog Output

1. All models come with bargraph, two open collector outputs, and one digital input standard.
2. The meter comes standard with three 3/4" NPT conduit holes.
3. To order models with different conduit holes, add the following at the end of the part number:
 - a. -21 for M20 conduit holes (e.g. PD6938-EX-SS-PNM-21)
 - b. -24 for one 1" bottom and two 3/4" NPT conduit holes (e.g. PD6938-EX-SS-PNM-24)
4. Battery powered meters with Explosion-Proof approval are available only with A and C Cell battery power options.
5. Modbus is standard on all DC powered models.
6. Modbus is not available with loop-powered models.

Accessories

Model	Description
PDABAT36C1-PACK	3.6 V Lithium Battery, C-Size
PDABAT36A1-PACK	3.6 V Lithium Battery, A-Size
PDABAT36AA3-PACK	3.6 V Lithium Battery Pack, 3xAA-Cell
PDAPLUG75	3/4" NPT 316 Stainless Steel Conduit Plug with Approvals
PDAPLUGM20	M20 316 Stainless Steel Conduit Plug with Approvals
PDAREDUCER-75M-50F	M-3/4" NPT to F-1/2" NPT Reducer with Approvals
PDAREDUCER-75M-M20F	M-3/4" NPT to F-M20 Reducer with Approvals
PDA8485-I	USB to RS-485 Isolated Converter
PDA6846-SS	Stainless Steel 2" U-Bolt Kit. All Material: Stainless Steel; (1) U-Bolt for 2" Pipe with (2) Washers, (2) Lock Washers, and (2) Nuts
PDA-MICROUSB	Micro-USB PC Programming Cable (supplied)
PDA-SSTAG	Custom Stainless Steel Tag (see website for convenient ordering form)

WARNING

- Accessories do not carry hazardous area approvals unless otherwise specified and are thus not suitable for location in hazardous areas.

PDA6846-SS 2" U-Bolt Kit



The PDA6846-SS Stainless Steel U-Bolt Kit provides a convenient way to mount the meter to 1.5" or 2" pipes.

PDA-SSTAG Stainless Steel Tag



The PDA-SSTAG is a laser etched stainless steel tag that can be customized with three lines of text. Each tag comes with a stainless steel wire and lead seal for easy mounting wherever you need.

Specifications

Except where noted all specifications apply to operation at +25°C.

Display

Display	Dual-line LCD with backlight. Both lines: alphanumeric Top: 0.7" (17.8 mm) 5 digits, 12-segment Bottom: 0.4" (10.2 mm) 8 characters, 14-segment Display may be programmed to turn red and flash a user-defined message on alarm condition.
LCD Sleep	Never, 1, 2, 5, 10, 20, 60 min Default: 10 min when battery powered; press any key for 2 sec to wake up the display. All inputs and outputs continue working.
Turn Meter Off/On	Press & hold the Menu key for 5 sec and follow the on-screen instructions. This feature helps extend battery life.
On-Screen Indicators	See <i>CapTouch Buttons and Status Indicators</i> on page 42 for details.
Top Display	5 digits (-9999 to 99999) or 5 characters (all capital & most lower-case letters)
Bottom Display	8 digits (-9,999,999 to 99,999,999; separated by commas) or 8 characters (all capital & most lower-case letters)
Backlight	Normal: white LED (enabled by default) Alarm: red LED (default) DC powered: steady on Battery powered: momentary (default: 10 sec) Output loop powered: varying intensity based on 4-20 mA output current
Bargraph	20 segments (100% label at top fixed) Assignable to rate, total, or off Scale: 0 to 100%
Display Assignment	Top & bottom displays can be assigned to rate, total, grand total, etc. See <i>Configuring the Display</i> (TOP and BOTTOM) on page 54 for a complete list of assignable parameters.
Decimal Point	Up to four decimal places on top display and up to seven decimal places on bottom display
Commas	Commas to indicate 1000s (e.g. 88,987,628) on the bottom display
Alarm Indication	Programmable: red backlight, flashing display, alarm symbol ▲, bargraph segment flashes on alarm.
Custom Alarm Messages	Programmable for each relay/open collector: 8 characters maximum; displayed every 10 sec for 1 sec on bottom display. May be turned off.
Display Update Rate	Ambient > -10°C: 4 updates/second Ambient = -20°C: 1 update/2 seconds From -20°C to -40°C the update rate slows down 1 second for every -2°C (e.g. at -24°C, 1 update/4 seconds). Below -40°C the display is not readable, but all the inputs and outputs work correctly.
Overrange	Top: 99999; Bottom: 99,999,999 (flashing)
Underrange	Top: -9999; Bottom: -9,999,999 (flashing)

General

Programming Method	Four CapTouch through-glass buttons when cover is installed. The CapTouch buttons can be used with the cover removed. Free PC-based USB MeterView XL programming software.
Recalibration	Recommended at least every 12 months.
Environmental	Operating temperature range: -40 to 75°C (-40 to 167°F) Storage temperature range: -55 to 85°C (-67 to 185°F) Installation temperature range: -55 to 75°C (-67 to 167°F) (The display ceases to function, however inputs and outputs continue to operate) Relative humidity: 0 to 90% non-condensing Printed circuit boards are conformally coated
Max / Min Display	Max / min readings reached by the process are stored until reset by the user or until power to the meter is turned off.
Password	There are three separate passwords available that can be set independently of each other: Main, Total, and Grand Total. The Main password prevents access to the meter Programming Mode. Total and Grand Total passwords prevent resetting the total and grand total, respectively.
Non-Volatile Memory	Total and Grand Total values, and all programmed settings are stored in non-volatile memory for a minimum of ten years if power is lost.
Power Options	9-30 VDC Powered, 2 W max Battery Powered or 9-30 VDC Powered with Battery Backup Loop Output Powered (30 VDC max) Loop Output Powered with Battery Backup
Data Logging	Up to 2,032 records, recorded 4/day at specific times or at defined time intervals. Record contains date, time, rate, total, grand total, and open collectors & relays states.
Data Logging Modes	Continuous: The log data will wrap around, erasing the oldest records to save the new records. Banks of 16 records will be erased at a time. Stop when full: The log will stop recording when full and "LOG FULL" is displayed every 10 sec.
Connections	Removable screw terminal blocks Display terminals: accept 16 to 30 AWG wire Relay terminals: accept 12 to 26 AWG wire 4-20 mA output: accept 16 to 30 AWG wire
Tightening Torque	Display terminals: 2.5 lb-in (0.28 Nm) Relay terminals: 4.5 lb-in (0.5 Nm) 4-20 mA output terminals: 2.5 lb-in (0.28 Nm)
Overall Dimensions	5.25" x 5.65" x 4.80" (133 x 144 x 122 mm) (W x H x D)
Weight	Aluminum: 5.1 lbs (2.3 kg) Stainless Steel: 9.4 lbs (4.3 kg)
Warranty	3 years parts and labor. See Warranty Information and Terms & Conditions on www.prediq.com for complete details.

Battery

Battery life is dependent on how the meter is used. Backlight should only be used momentarily (10 sec on). Modbus should rarely be used on battery-power, it requires approximately 26 mA. See battery life tables below for details.

-IS Models (Options: P & R) 3xAA-Cell

Battery Type	3.6 V Lithium (Li-SOCl ₂), non-rechargeable P/N: PDABAT36AA3-PACK		
Battery Life	Operating Condition @ 2,000 Hz	Estimated Service Life	Suggested Replacement Interval
	Monitoring only, backlight off	35 months	30 months
	LCD sleep*, minimal CapTouch use, backlight off	57 months	50 months
	100 Hz open collector 1&2 outputs, minimal backlight use	24 months	20 months
Battery Replacement	Replace only with a Precision Digital original Model PDABAT36AA3-PACK		

-EX Models (Options: A & M) A-Size

Battery Type	3.6 V Lithium (Li-SOCl ₂), non-rechargeable P/N: PDABAT36A1-PACK		
Battery Life	Operating Condition @ 2,000 Hz	Estimated Service Life	Suggested Replacement Interval
	Monitoring only, backlight off	17 months	15 months
	LCD sleep*, minimal CapTouch use, backlight off	28 months	25 months
	100 Hz open collector 1&2 outputs, minimal backlight use	12 months	10 months
Battery Replacement	Replace only with a Precision Digital original Model PDABAT36A1-PACK		

-EX Models (Options: B & N) C-Size

Battery Type	3.6 V Lithium (Li-SOCl ₂), non-rechargeable P/N: PDABAT36C1-PACK		
Battery Life	Operating Condition @ 2,000 Hz	Estimated Service Life	Suggested Replacement Interval
	Monitoring only, backlight off	37 months	32 months
	LCD sleep*, minimal CapTouch use, backlight off	61 months	53 months
	100 Hz open collector 1&2 outputs, minimal backlight use	26 months	21 months
Battery Replacement	Replace only with a Precision Digital original Model PDABAT36C1-PACK		

Battery Life with Modbus Continuously On

3XAA-Cell	277 hours
A-Size	138 hours
C-Size	296 hours

*LCD sleep: Press any key to wake up the display. All input & outputs continue working in LCD Sleep mode.

Enclosure

Material	-AL Models: ASTM A413 LM6 die-cast aluminum, copper-free, enamel coated. -SS Models: ASTM A743 CF8M investment-cast 316 stainless steel
Gasket	Fluoroelastomer
Rating	NEMA 4X, IP68 Explosion-Proof
Color	-AL: Blue; -SS: Silver
Window	Borosilicate glass
Conduits	Three 3/4" NPT or M20 threaded conduit openings. Optionally, the bottom opening can be supplied with 1" NPT opening. See <i>Ordering Information</i> on page 13 for details.
Conduit Stopping Plug	Sold separately. See <i>Ordering Information</i> on page 13 for details.
Flange	Built-in flange for wall and pipe mounting.
Tamper-Proof Seal	Enclosure lid may be secured with tamper-proof seal.
Instrument Tag Loop	Built-in loop for securing stainless steel tag
Overall Dimensions	5.25" x 5.65" x 4.80" (133 x 144 x 122 mm) (W x H x D)
Weight	Aluminum: 4.8 lbs (2.18 kg) Stainless Steel: 9.0 lbs (4.08 kg)

Pulse Input

Pulse, Transistor, Contact Closure	Pulse or square wave: 0-5 V, 0-12 V, or 0-24 V; TTL; NPN or PNP Open collector: 100 kΩ pull-up to 2.8 V Switch contact: 100 kΩ pull-up to 2.8 V PNP transistor: 100 kΩ pull-down to ground Active input: 100 kΩ pull-up to 2.8 V NPN strong: 10 kΩ pull-up to 2.8 V (Do not use with battery power) Maximum Frequency: 100 kHz Minimum Pulse Width: 5 μs <table border="1"> <thead> <tr> <th>Threshold Setting</th> <th>Low (V)</th> <th>High (V)</th> </tr> </thead> <tbody> <tr> <td>Active/NPN</td> <td>0.5</td> <td>1.8</td> </tr> <tr> <td>Active/NPN High</td> <td>2.8</td> <td>4.8</td> </tr> </tbody> </table>	Threshold Setting	Low (V)	High (V)	Active/NPN	0.5	1.8	Active/NPN High	2.8	4.8
Threshold Setting	Low (V)	High (V)								
Active/NPN	0.5	1.8								
Active/NPN High	2.8	4.8								
Magnetic Pickup Coil	Sensitivity: 10 mVp-p to 24 Vp-p Maximum Frequency: 40 kHz Note: 10 mVp-p @ 300 Hz max									
Sensor Power	5 VDC @ 5 mA Enabled in the Advanced – System menu									
Minimum Input Frequency	0.0001 Hz Minimum frequency is dependent on high gate setting (rate display)									
Input Impedance	Pulse input: Greater than 75 kΩ @ 1 kHz. Open collector/switch: 100 kΩ pull-up to 2.8 V									
Contact Debounce Filter	Programmable contact debounce filter. Input signal frequency speed selections: Disable: Greater than 100 kHz (no filter) Fast: 1,000 Hz Medium: 240 Hz Slow: 100 Hz									
Accuracy	Rate: ±0.02% of calibrated span ±1 count Total: Every input pulse is counted									
Temperature Drift	2 PPM/°C from -40 to 75°C ambient									
Function	K-Factor: 0.000001 to 9,999,999 Rate: Linear (2-32 points)									
Low-Flow Cutoff	0.1 to 999,999 or disable. Point below at which the display always shows zero.									
HART Transparency	The 4-20 mA output does not interfere with existing HART communications.									

Rate/Totalizer

Rate Display	Top display: -9999 to 99999; Bottom display: -9,999,999 to 99,999,999 (with commas)
Total & Grand Total Display	Top display: 0 to 99999; Bottom display: 0 to 99,999,999 (with commas)
13-Digit Total & Grand Total	Up to 9,999,999,999,999 using both lines with 13-digit total feature enabled.
Total Decimal Point	Up to four decimal places on top, up to seven decimal places on bottom. Total decimal point is independent of rate decimal point.
Totalizer	Calculates total based on input pulses and rate units to display total in engineering units. A custom factor must be programmed if using custom defined units.
Time Base	Seconds, Minutes, Hours, Days
Totalizer Rollover	Totalizer rolls over when display exceeds 99,999,999 (9,999,999,999,999 if 13-digit limit enabled). Relay status reflects display.
Total & Grand Total Reset	Via CapTouch button, external contact closure on digital input, automatic based on time of day, or MeterView XL.
Time of Day Total & Grand Total Reset	Four programmable reset times. The total and grand total can be set up to reset at a time of day every day or any day.
Previous Total & Grand Total	Total & grand total are saved prior to applying the reset command. The previous totals can be read via the F1 function key and the Modbus registers.
Total & Grand Total Reset Passwords	Total and grand total passwords may be entered to prevent resetting the total or grand total unless a password is entered.
Non-Resettable Grand Total	Grand total reset may be disabled through the meter interface. Grand total reset may be permanently disabled by selecting YES at the PERMLCK menu.
⚠ CAUTION <ul style="list-style-type: none"> Once the Grand Total has been programmed as "non-resettable" the feature CANNOT be disabled. 	
Non-Volatile Memory	Total and Grand Total values are stored in non-volatile memory for a minimum of ten years if power is lost.

Batch Control

Methods	Automatic or Manual, count up or count down
Manual Batch Start	Pressing F1 function key starts the batch
Manual Batch Pause/Stop	Pressing F3 once pauses the batch, pressing it twice cancels the batch
Automatic Batching	The ProtEX+ can be used as an automatic batch controller where batches run continuously without operator input
Batching Relay Operation	Single or dual-relay batching with optional preclose for dual-stage operation
Batch Preset	Set via F2 function key anywhere between 0.0001 to 99,999 based on batch total decimal point. If batch total is assigned to bottom, the preset can be up to 8 digits.
Batch Preclose	For two-stage batch application, a preclose value can be set to close the main flow line.
Automatic Batch Restart Delay	1 to 9,999 seconds. The batch will automatically restart after completion of the last batch.

Common Open Collector & Relay Specifications

Number	Two open collectors & two relays
High or Low Alarm	User programmable for high or low alarm
Alarm Deadband	0-100% FS, user programmable
Output Assignment	Alarm, Timer, Stopwatch, or Disable
Alarm Output Source	Assign to rate, total, grand total, or digital input
On & Off Time Delay	0 to 9,999 seconds
Fail-Safe Operation	Independent for each open collector and relay. Fail-safe on, the output is on under normal conditions. Fail-safe off, the output is on under alarm conditions.
Alarm Operation	Automatic, automatic with manual override, latching (manual reset anytime), latching with reset after cleared (manual reset only after alarm has cleared)
Alarm Indication	Programmable: loop-powered red backlight, flashing display, alarm symbol ▲, bargraph segment flashes on alarm.
Custom Alarm Messages	Programmable for each relay/open collector: 8 characters maximum; displayed every 10 sec for 1 sec on bottom display. May be turned off.
Alarm Acknowledge	CapTouch ACK button or external digital input resets output and screen indication.
Auto Initialization	When power is applied to the meter, open collectors and relays will reflect the state of the input to the meter.
Timer Output	One-shot or Continuous Off Time Delay: 1 sec to 99:59:59 (hrs:min:sec) On Time: 1 sec to 99:59:59 (hrs:min:sec)
Stopwatch	Output turns on when started and off when stopped.

Open Collector Outputs

Rating	Isolated open collector, sinking NPN 5-30 VDC @ 150 mA maximum
Output Assignment	Pulse, Alarm, Timer, Stopwatch, or Disable
Pulse Output Source	Pulse output based on Rate, Total, Grand Total, or Test Frequency, Alarm, Timer, Total Reset, Stopwatch on/off, or Disable
Pulse Output Factor	0.000001 to 999,999.9
Pulse Width	0.25 ms @ 2 kHz; 500 ms @ 1 Hz; 50% duty cycle
Pulse Output Frequency	2,000 Hz maximum
Quadrature Pulse Output	Available for Output 2 (90° behind Output 1) 1000 Hz max
Alarm Output Source	Assign to Rate, Total, Grand Total or Digital Input

Solid-State Relays

Rating	250 VAC/VDC @ 0.5 A resistive 38 VA; 250 VAC; 0.3 A pilot duty (inductive) 13 VA; 250 VDC; 0.3 A pilot duty (inductive)
Noise Suppression	Metal oxide varistors across outputs
Relay Assignment	Alarm, Sample, Timer, Batch, Stopwatch on/off, or Disable
Alarm Output Source	Assign to Rate, Total, Grand Total, or Digital Input
Relay Runtime	Meter will keep track of how long each relay has operated and display this information.
Relay Cycles	Meter will keep track of how many times the relays have cycled and display this information.

4-20 mA Transmitter Output

Accuracy	±0.05% FS ±0.001mA
Output Source	Rate, total; reverse scaling allowed
Scaling Range	1.00 to 23.0 mA
Disable	High impedance state, less than 1 mA
Calibration	Factory calibrated: 0 to 100 GAL/Sec = 4.00 to 20.00 mA
Underrange	1.0 mA, 3.5 mA, 3.8 mA; or Off; user selectable
Overrange	20.5 mA, 20.8 mA, 23.0 mA, or Off; user selectable
Isolation	500 V input-to-output
Temperature Drift	0.003 mA max from -40 to 75°C ambient
External Loop Power Supply	7.0 VDC to 30.0 VDC maximum
Output Loop Resistance	10-750 Ω @ 24 VDC; 10-1100 Ω @ 30 VDC (External resistance to maintain accuracy)

On-Board Digital Input

Function	Remote operation of front-panel buttons, acknowledge/reset relays, reset total, reset max/min values, start/stop batch, etc. See User section of <i>Display Functions & Messages</i> on page 43 for a complete list of capabilities.
Contacts	2.1 VDC on contact. Connect normally open contacts across G and +
Logic Levels	Logic High: 2.4 to 30 VDC (max) Logic Low: 0 to 0.9 VDC

Serial Communications

Connection	RS-485, 3-wire; Isolation: 500 V. Non-isolated micro-USB.
Protocol	Modbus® RTU
Meter Address / Slave ID	1 - 247
Baud Rate	1,200; 2,400; 4,800; 9,600; 19,200; 38,400; or 57,600 bps.
Transmit Time Delay	Programmable between 0 and 199 ms
Parity/Stop Bit	Even, odd, or none with 1 or 2 stop bits
Byte-to-Byte Timeout	Max of 1.5 character times or 2.25 ms
<i>Note: Refer to the ProtEX+ and VantageView+ PD6938 Modbus® Register Tables located at www.prediq.com for details.</i>	

MeterView XL Software

Availability	Free download from www.prediq.com/meterviewxl
System Requirements	Microsoft® Windows® 10 & 11
Communications	USB 2.0 (Standard USB A to Micro USB B) Cable provided
Configuration	Configure all parameters on the meter. Configure meters one at a time.
Configuration Files	Generate with or without meter connected; Save to file for later use.
USB Power Connection	The meter is powered by the USB connection during programming. There is no need to apply external power. Note: The meter will not be damaged if external power is applied to it during programming.

WARNING

- The meter should only be connected to a computer while it is located in a safe area

Data Logging Report	The on-board data log can be downloaded via the USB or the RS-485 connection. Saved as ".csv" file format.
PC Data Logging	MeterView XL can be used to data log directly to a computer connected to the meter via the USB or the RS-485 connection. The user can select what to log and at what interval. <ul style="list-style-type: none"> • Rate • Total • Grand total • Open collector triggers • Relay triggers • Hold/Unhold outputs
Compatibility	Programs created for VantageView+ and ProtEX+ can be run on either meter. No other program sharing is permissible.

To download the latest MeterView XL programming software and manual, visit prediq.com/meterviewxl.

General Compliance Information

Electromagnetic Compatibility

- | | |
|----------------------|---|
| EMC Emissions | <ul style="list-style-type: none"> • CFR 47 FCC Part 15 Subpart B Class A emissions requirements (USA) • ICES-003 Information Technology emissions requirements (Canada) • AS/NZS CISPR 11 Group 1 Class A ISM emissions requirements (Australia/New Zealand) • EN 55011 Group 1 Class A ISM emissions requirements (EU) • EN 61000-6-4 Emissions requirements for Heavy Industrial Environments - Generic |
|----------------------|---|

- | | |
|-----------------------------------|--|
| EMC Emissions and Immunity | EN 61326-1 EMC requirements for Electrical equipment for measurement, control, and laboratory use – industrial use |
|-----------------------------------|--|

Hazardous Area Approvals

-HA Models (Dual Hazardous Approved)

UL	Explosion-Proof for use in: For Class I, Division 1, Groups B, C, D Class II, Division 1, Groups E, F, G Class III, Division 1; T6 Class I, Zone 1, AEx db IIC T6 Gb Zone 21, AEx tb IIIC T85°C Db Tamb = -55°C to 75°C UL Type 4X, IP66 / IP68 UL File Number: E494837
CSA	Explosion-Proof for use in: Class I, Division 1, Groups B, C and D Dust Ignition-Proof for use in: Class II/III, Division 1, Groups E, F and G; T6 Flame-Proof for use in: Class I, Zone 1, Ex d IIC T6 Ta = -55 to 75°C Enclosure: Type 4X & IP66/IP68 Certificate Number: CSA 11 2325749
ATEX	Intrinsically Safe for use in: ⊕ II 1 G D Ex ia IIC T4 Ga Ex ia IIIC T200°C Da Ta = -55 to 75°C Enclosure: Type 4X & IP66/IP68 Install per Control Drawing DW2636 (contained within LIM6938-2) Certificate Number: CML 18ATEX2089X Explosion-Proof for use in: ⊕ II 2 G D Ex db IIC T6 Gb Ex tb IIIC T85°C Db IP68 Ta = -55 to 75°C Enclosure: Type 4X & IP66/IP68 Certificate Number: Sira 10ATEX1116X
IECEX	Intrinsically Safe for use in: Ex ia IIC T4 Ga Ex ia IIIC T200°C Da Ta = -55 to 75°C Enclosure: Type 4X & IP66/IP68 Install per Control Drawing DW2636 (contained within LIM6938-2) Certificate Number: IECEX CML 18.0050X Explosion-Proof for use in: Ex db IIC T6 Gb Ex tb IIIC T85°C Db IP68 Ta = -55 to 75°C Enclosure: Type 4X & IP66/IP68 Certificate Number: IECEX SIR 10.0056X

-IS Models (Intrinsically Safe Approved)

ATEX	Intrinsically Safe for use in: ⊕ II 1 G D Ex ia IIC T4 Ga Ex ia IIIC T200°C Da Ta = -55 to 75°C Enclosure: Type 4X & IP66/IP68 Install per Control Drawing DW2636 (contained within LIM6938-2) Certificate Number: CML 18ATEX2089X
IECEX	Intrinsically Safe for use in: Ex ia IIC T4 Ga Ex ia IIIC T200°C Da Ta = -55 to 75°C Enclosure: Type 4X & IP66/IP68 Install per Control Drawing DW2636 (contained within LIM6938-2) Certificate Number: IECEX CML 18.0050X

-EX Models (Explosion-Proof Approved)

UL	Explosion-Proof for use in: For Class I, Division 1, Groups B, C, D Class II, Division 1, Groups E, F, G Class III, Division 1; T6 Class I, Zone 1, AEx db IIC T6 Gb Zone 21, AEx tb IIIC T85°C Db Tamb = -55°C to 75°C UL Type 4X, IP66 / IP68 UL File Number: E494837
CSA	Explosion-Proof for use in: Class I, Division 1, Groups B, C and D Dust Ignition-Proof for use in: Class II/III, Division 1, Groups E, F and G; T6 Flame-Proof for use in: Zone 1, Ex d IIC T6 Ta = -55 to 75°C Enclosure: Type 4X & IP66/IP68 Certificate Number: CSA 11 2325749
ATEX	Explosion-Proof for use in: ⊕ II 2 G D Ex db IIC T6 Gb Ex tb IIIC T85°C Db IP68 Ta = -55 to 75°C Enclosure: Type 4X & IP66/IP68 Certificate Number: Sira 10ATEX1116X
IECEX	Explosion-Proof for use in: Ex db IIC T6 Gb Ex tb IIIC T85°C Db IP68 Ta = -55 to 75°C Enclosure: Type 4X & IP66/IP68 Certificate Number: IECEX SIR 10.0056X

ATEX/IECEX Specific Conditions of Use

The following conditions relate to safe installation and/or use of the equipment.

-HA and -IS Models

- The equipment loop/power port shall be connected to an intrinsically safe barrier with $U_o \geq 5.8V$
- The Pulse and Mag inputs shall not both be connected to external equipment simultaneously.
- The PD6938-HA-AL and PD6938-IS-AL enclosure is manufactured from aluminum. In rare cases, ignition sources due to impact and friction sparks could occur. This shall be considered during installation, particularly if the equipment is installed in a Zone 0 location.
- All cable entries into the equipment shall be via cable glands or conduit which provide a minimum degree of protection of IP54.
- The equipment may not have 500V isolation between the circuit and earth. This shall be taken into account when installing the equipment.

-HA and -EX Models

- The equipment label and epoxy coating may generate an ignition-capable level of electrostatic charges under certain extreme conditions. The user should ensure that the equipment is not installed in a location where it may be subjected to external conditions (such as high-pressure steam) which might cause a buildup of electrostatic charges on non-conducting surfaces. Additionally, cleaning of the equipment should be done only with a damp cloth.
- Flameproof joints are not intended to be repaired.
- All entry closure devices shall be suitably certified as "Ex d", "Ex t" and "IP66/68" as applicable. Suitable thread sealing compound (non-setting, non-insulating, non-corrosive, not solvent based, suitable for the ambient rating) must be used at the NPT conduit entries to achieve the IPx8 rating while maintaining the Ex protection concept.

-EX and -IS Models

- The battery shall not be recharged, in addition, it shall only be replaced by a Precision Digital battery with the same part number as the one being replaced. See *Battery* specifications on page 20 for details.

Year of Construction

This information is contained within the serial number with the first four digits representing the year and month in the YYYYMM format.

For European Community:**-HA Models**

The PD69XX Series must be installed in accordance with the ATEX directive 2014/34/EU, the product certificates CML 18ATEX2089X, Sira 10ATEX1116X, IECEx CML 18.0050X, IECEx SIR 10.0056X and the product manual.

-IS Models

The PD69XX Series must be installed in accordance with the ATEX directive 2014/34/EU, the product certificates CML 18ATEX2089X, IECEx CML 18.0050X, and the product manual.

-EX Models

The PD69XX Series must be installed in accordance with the ATEX directive 2014/34/EU, the product certificates Sira 10ATEX1116X, IECEx SIR 10.0056X and the product manual.

UL Specific Conditions of Safe Use

- Flameproof joints are not intended to be repaired.
- "WARNING - Potential Electrostatic Charging Hazard – See Instructions." Anodized or epoxy coated aluminum models must not be installed in locations where they may be subjected to conditions (such as high-pressure steam) which might cause a build-up of electrostatic charges on non-conductive surfaces. Additionally, cleaning of the equipment should only be done with a damp cloth.
- (Only in models with the battery) The battery shall not be recharged. In addition, it shall only be replaced by a Precision Digital battery with the same part number as the one being replaced.
- The equipment has not been evaluated for sealing of process fluids. The final installation shall include suitable sealing of the process fluids.
- The process temperature range shall not exceed the ambient temperature range of the equipment, if attached.

EU Declaration of Conformity

For shipments to the EU and UK, a Declaration of Conformity was printed and included with the product. For reference, a Declaration of Conformity is also available on our website www.predig.com/docs.

Safety Information

CAUTION

- Read complete instructions prior to installation and operation of the meter.

WARNINGS

- Hazardous voltages exist within enclosure. Installation and service should be performed only by trained service personnel.
- The internal grounding terminal shall be used for the equipment grounding connection and that the external terminal is for a supplementary bonding connection where local codes or authorities permit or require such connection.
- If this equipment is used in a manner not specified by Precision Digital, the protection provided by the equipment may be impaired.
- Substitution of components may impair hazardous location safety.
- Service requiring replacement of internal components must be performed at the factory. Entire meter assembly (electronic assembly) may be replaced within the field with a unit supplied from the factory labeled "Field Modification".
- Control room equipment must not use or generate more than 250 VRMS or VDC.
- Hazardous location installation instructions for associated apparatus (barrier) must be followed when installing this equipment.
- For safe installation of an ATEX approved flowmeter with PD6938 rate/totalizers, the hazardous location installation instructions for the flowmeter, PD6938 flow rate/totalizer, and associated apparatus (barrier) must be compatible.
- PD6938 powered by the 4-20 mA output loop do not add capacitance or inductance to the loop under normal or fault conditions.
- Substitution of components may impair hazardous location safety.
- Equipment contains non-metallic materials and therefore special care and consideration should be made to the performance of these materials with respect to chemicals which may be present in a harsh operating environment.

Installation

To access the connectors, remove the enclosure cover and unclip the display module by pulling it from the enclosure. The display module may be disconnected from the options module to facilitate wiring to the options module.

Refer to Control Drawing DW2636 (contained within [LIM6938-2](#)) for details related to intrinsically safe field wiring.

WARNING

Explosion-Proof / Dust Ignition-Proof / Flame-Proof

- Disconnect from supply before opening enclosure.
- Keep cover tight while circuits are live.
- The equipment shall only be connected to a Class 2 power supply.
- All conduit openings must be fitted with suitably certified and dimensioned cable entry devices or stopping plugs.
- Install conduit seals within 18 in. (450 mm) of enclosure.
- Cable must be suitable for 90°C.

Unpacking

Remove the meter from box. Inspect the packaging and contents for damage. Report damages, if any, to the carrier.

If any part is missing or the meter malfunctions, please contact your supplier or the factory for assistance.

Mounting

The PD6938 has a slotted mounting flange that may be used for pipe mounting or wall mounting. Alternatively, the unit may be supported by the conduit using the conduit holes provided. Refer to *Figure 1* and *Figure 2*.

⚠ WARNING

- Do not attempt to loosen or remove flange bolts while the meter is in service.

Dimensions

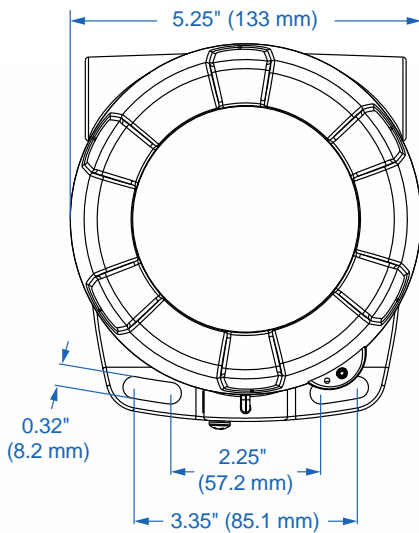

Figure 1. Enclosure Dimensions – Front View

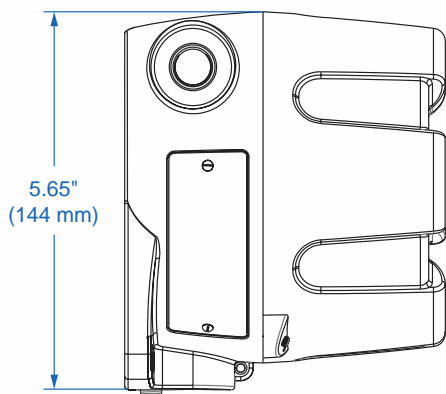

Figure 2. Enclosure Dimensions – Side View

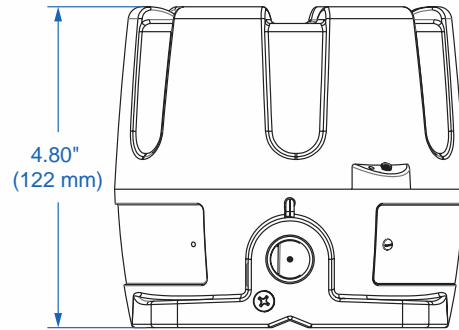

Figure 3. Enclosure Dimensions – Bottom View



Download free 3-D CAD files of these instruments to simplify your drawings!

predig.com/documentation-cad

Cover Jam Screw

The cover jam screw should be properly installed once the meter has been wired and tested in a safe environment. The cover jam screw is intended to prevent the removal of the meter cover in a flame-proof environment without the use of tools. Using a M2 hex wrench, turn the screw clockwise until the screw contacts the enclosure's base. Turn the screw an additional 1/4 to 1/2 turn to secure the cover.



⚠ CAUTION

- Excess torque may damage the threads, screw head, and/or wrench.

Connections

To access the connectors, remove the enclosure cover and unclip the display module by pulling it from the enclosure. Signal, backlight, open collector, and digital input connections are made to removable connectors on the display module. Relays and 4-20 mA output connections (if installed) are made to removable connectors on the options module mounted in the base of the enclosure. The display module may be disconnected from the options module to facilitate wiring to the options module. Grounding connections are made to the two ground screws provided on the base of the enclosure, one internal and one external.

⚠ WARNINGS

- Observe all safety regulations. Electrical wiring should be performed in accordance with all agency requirements and applicable national, state, and local codes to prevent damage to the meter and ensure personnel safety.
- Static electricity can damage sensitive components.
- Observe safe handling precautions for static-sensitive components.
- If the meter is installed in a high voltage environment and a fault or installation error occurs, high voltage may be present on any lead or terminal.

Display & Options Modules

The display module snaps into built-in rails on the enclosure ensuring a secure and perfect fit every time. No tools are needed to install or remove it. The options module is screwed into the base of the enclosure. Both modules completely encase the printed circuit boards.

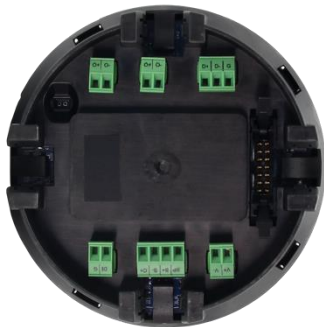

Display Module



Options Module (Left) and Display Module (Right)



Options Module Mounted on the Bottom of Enclosure



Display Module Mounted on Built-In Rails
(No Tools Required)

Connectors Labeling

The following graphics show the locations of the connectors for each available configuration.

DC Powered Models (-D Option)

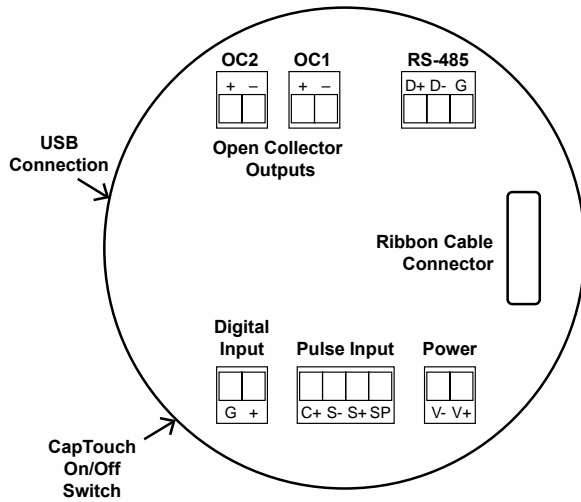

Open Collectors, Digital Input, RS-485, DC Power	
Connector	Description
OC1	Open Collector 1
OC2	Open Collector 2
RS-485	RS-485 Modbus RTU
Digital Input	G, +
Power	V+, V- (9-30 VDC)
Pulse Input	
Connector	Description
C+	Magnetic Pickup Coil
S-	Signal -
S+	Signal +
SP	Sensor Power (5 V @ 5 mA)

Figure 4. Connector Labeling for PD6938-##-##-DNM

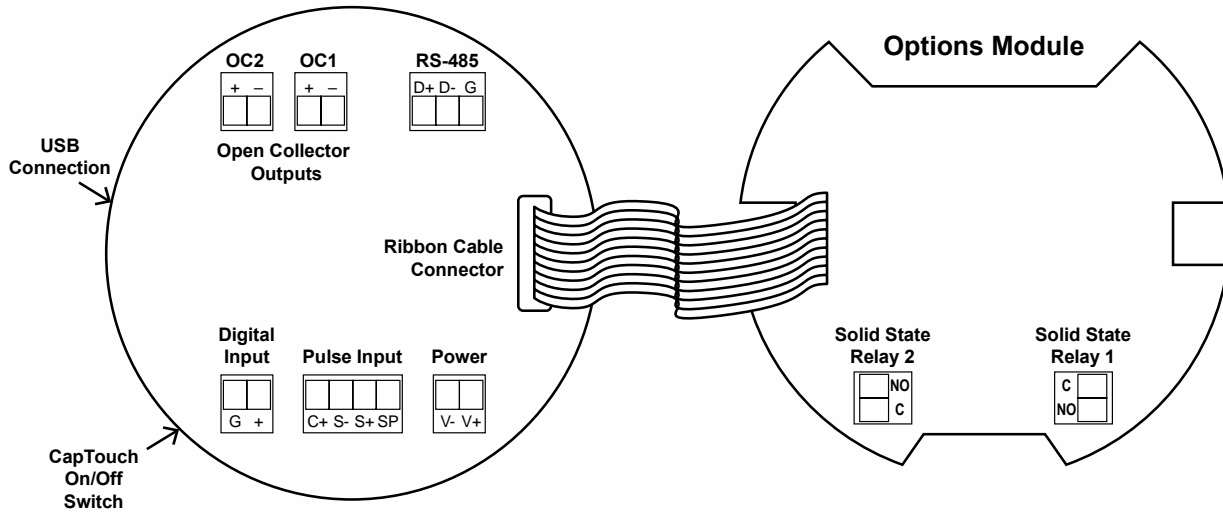

Figure 5. Connector Labeling for PD6938-##-##-D2M

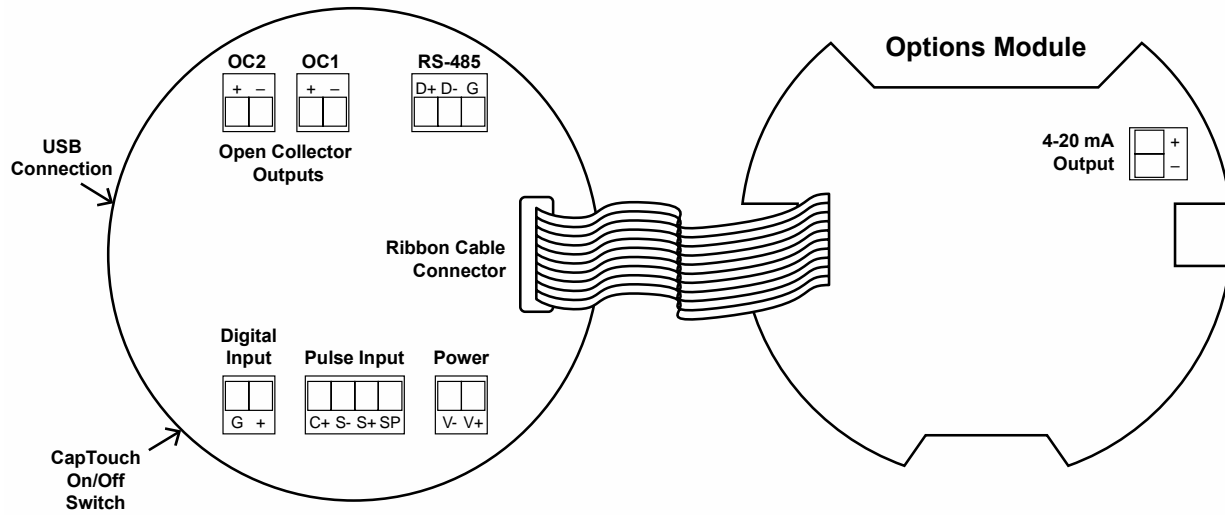

Figure 6. Connector Labeling for PD6938-##-##-D3M

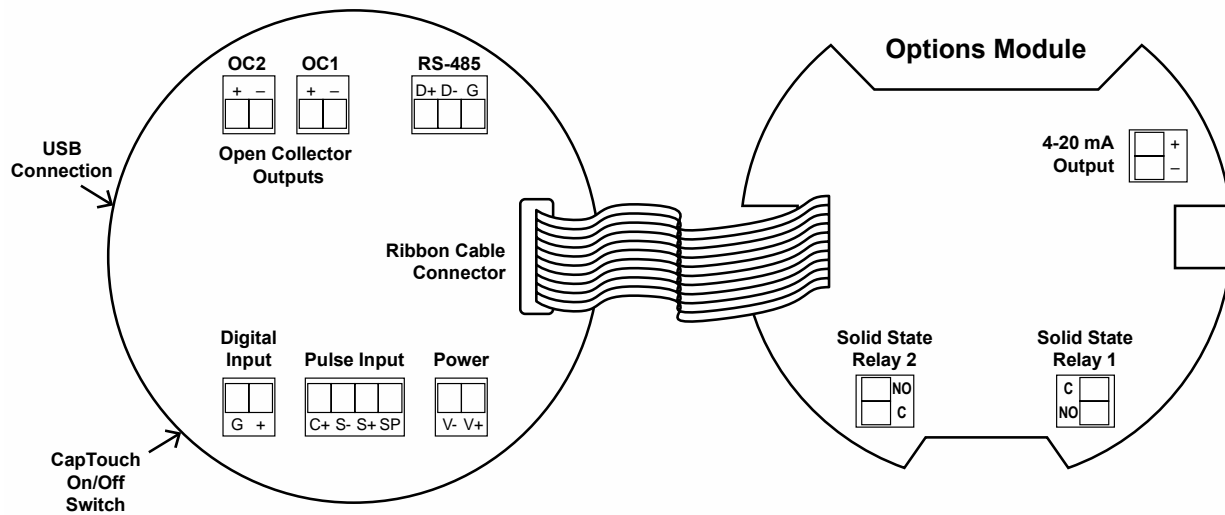

Figure 7. Connector Labeling for PD6938-##-##-D5M

DC Powered with Battery Backup Models (-A, -B, -P Options)

Open Collectors, Digital Input, RS-485, DC Power		Pulse Input	
Connector	Description	Connector	Description
OC1	Open Collector 1	C+	Magnetic Pickup Coil
OC2	Open Collector 2	S-	Signal -
RS-485	RS-485 Modbus RTU	S+	Signal +
Digital Input	G, +	SP	Sensor Power (5 V @ 5 mA)
Power	V+, V- (9-30 VDC)		

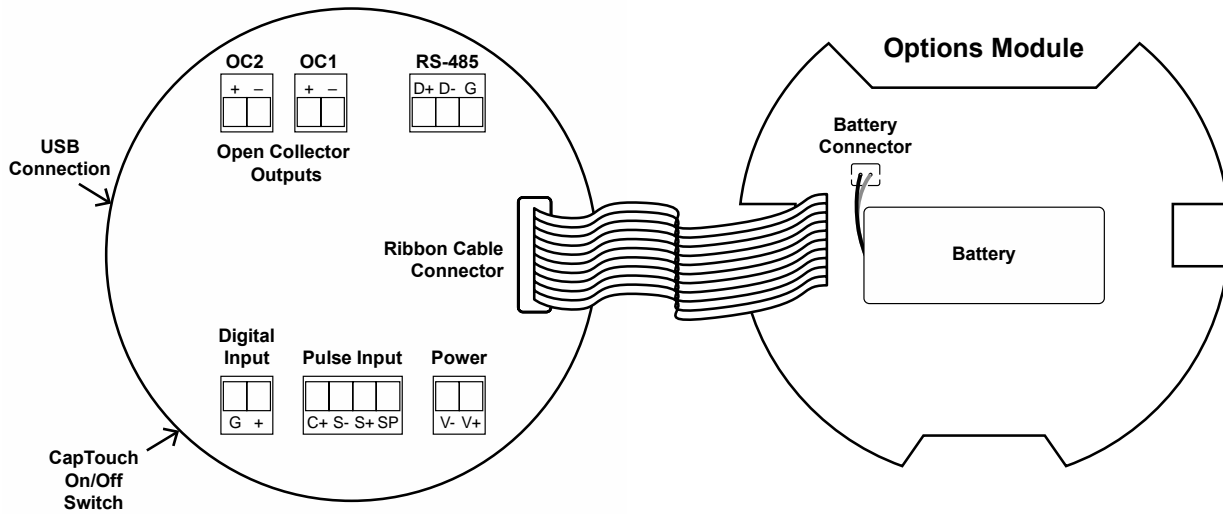

Figure 8. Connector Labeling for PD6938-##-##-ANM, -BNM, -PNM

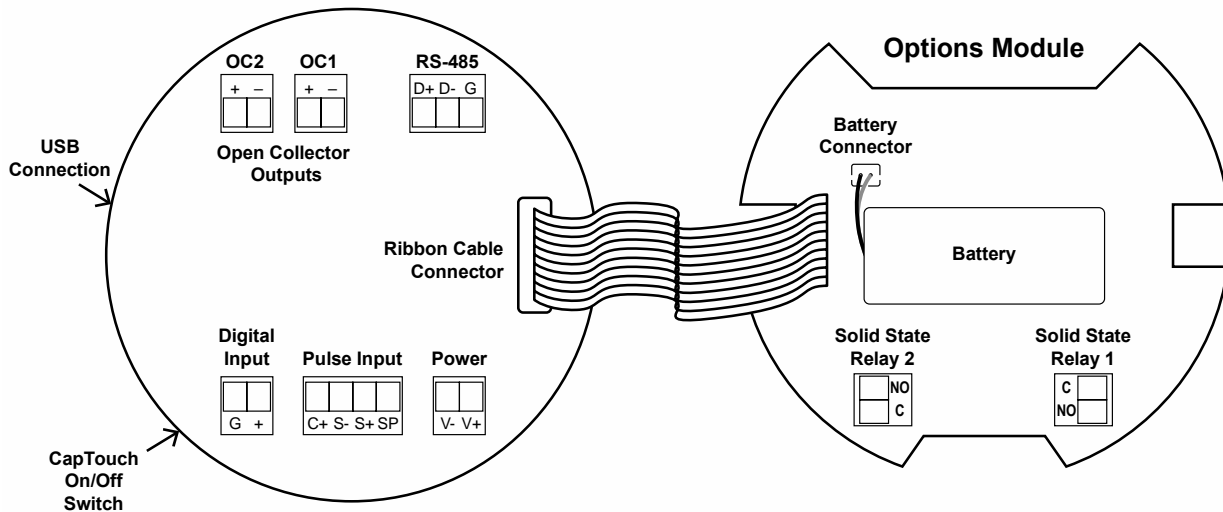

Figure 9. Connector Labeling for PD6938-##-##-A2M, -B2M, -P2M

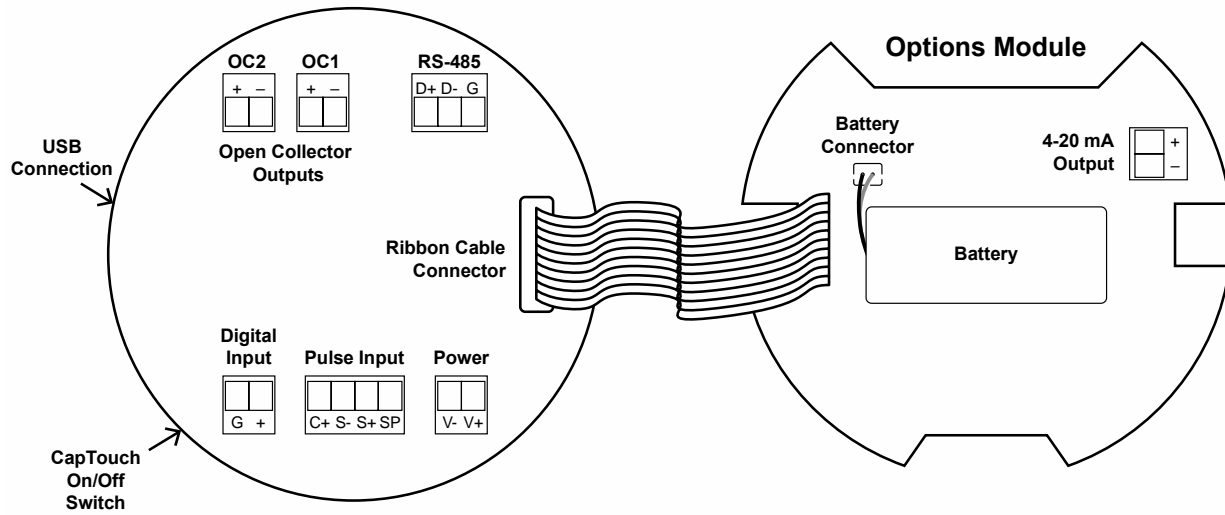

Figure 10. Connector Labeling for PD6938-##-##-A3M, -B3M, -P3M

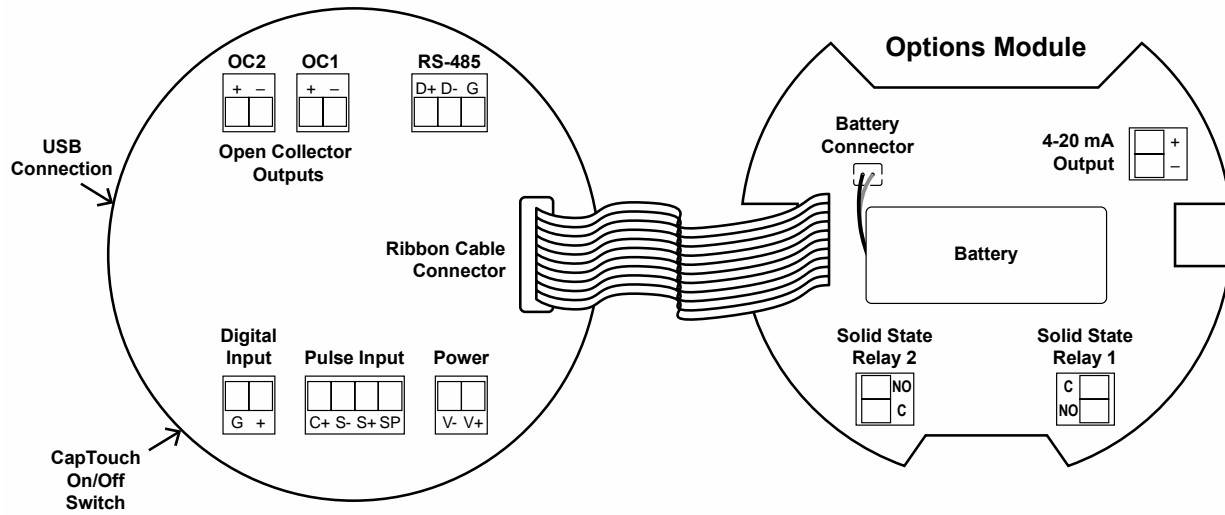

Figure 11. Connector Labeling for PD6938-##-##-A5M, -B5M, -P5M

Loop Output Powered Models (-C Option)

Open Collectors and Digital Input		Pulse Input	
Connector	Description	Connector	Description
OC1	Open Collector 1	C+	Magnetic Pickup Coil
OC2	Open Collector 2	S-	Signal -
Digital Input	G, +	S+	Signal +
		SP	Sensor Power (5 V @ 5 mA)

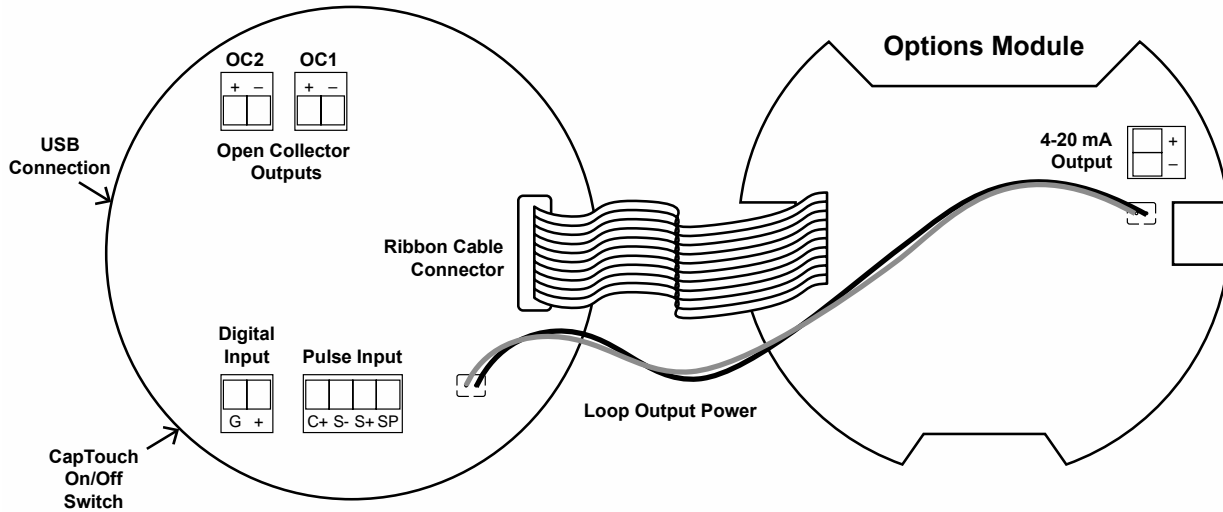

Figure 12. Connector Labeling for PD6938-##-##-C3N

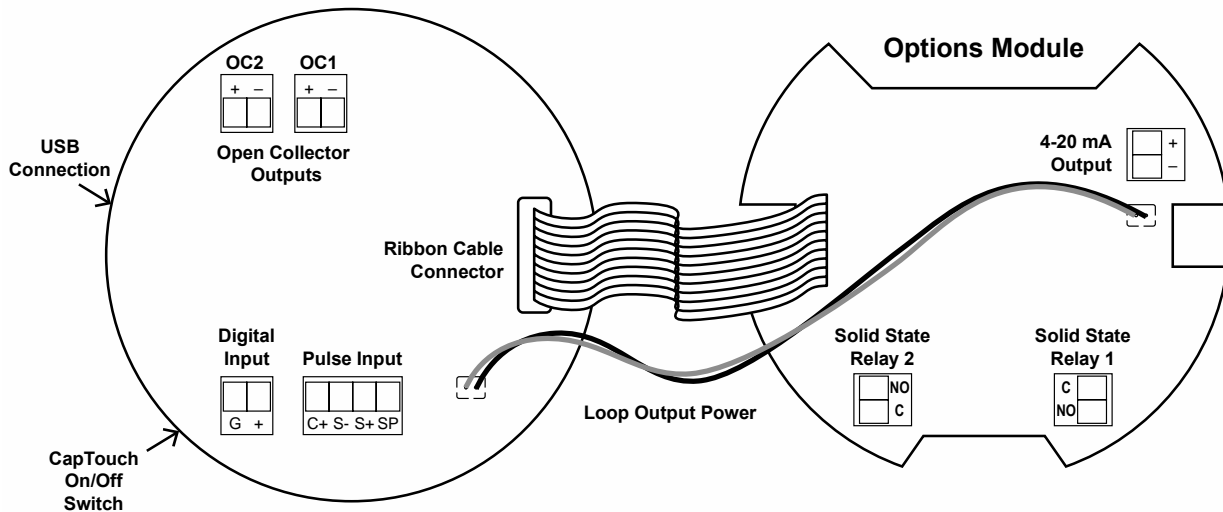

Figure 13. Connector Labeling for PD6938-##-##-C5N

Loop Output Powered with Battery Backup Models (-R, -M, -N Options)

Open Collectors and Digital Input		Pulse Input	
Connector	Description	Connector	Description
OC1	Open Collector 1	C+	Magnetic Pickup Coil
OC2	Open Collector 2	S-	Signal -
Digital Input	G, +	S+	Signal +
		SP	Sensor Power (5 V @ 5 mA)

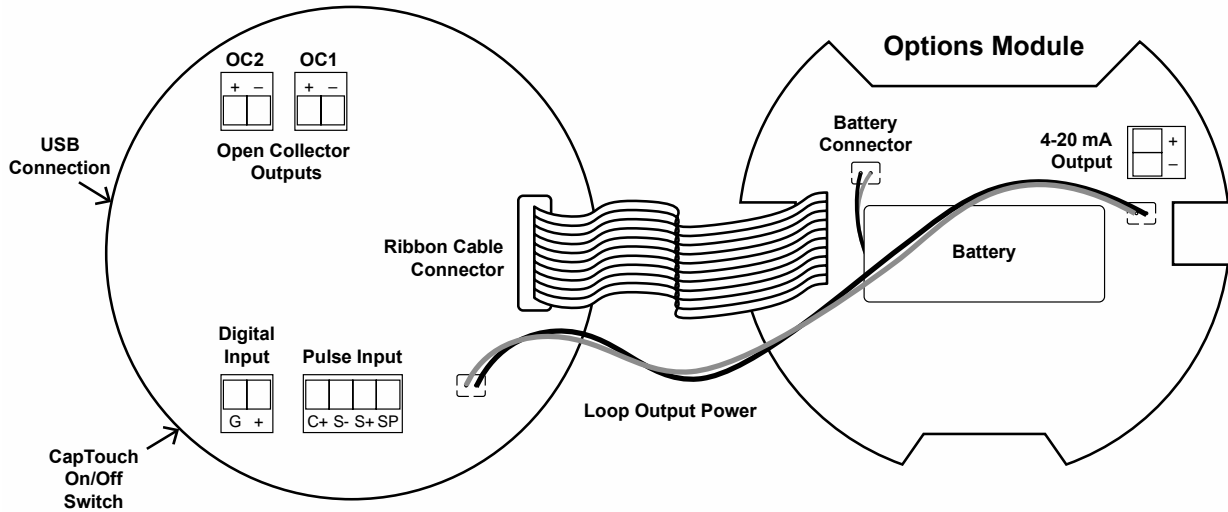

Figure 14. Connector Labeling for PD6938-##-##-R3N, -M3N, -N3N

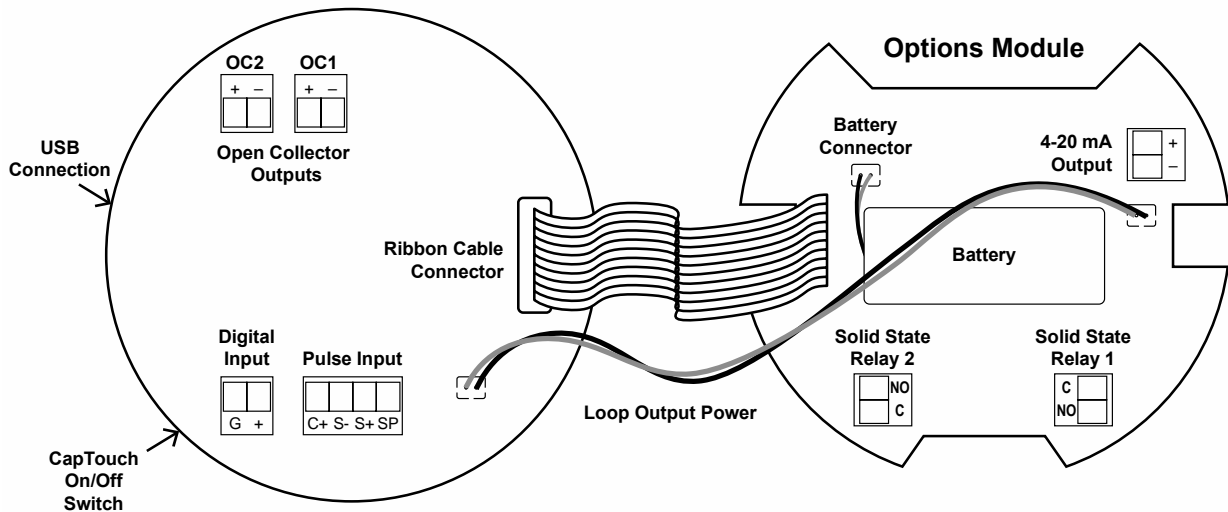

Figure 15. Connector Labeling for PD6938-##-##-R5N, -M5N, -N5N

Wiring Diagrams

Intrinsically Safe Wiring (-HA and -IS Models)

⚠ WARNING

- PD6938 installation must be performed in accordance with control drawings included in [LIM6938-2](#), in order to meet agency approval ratings.
- For ATEX certification, barrier and transmitter must be ATEX Certified with Entity Parameters and must be connected per manufacturer's instructions.
- Service requiring replacement of internal components must be performed at the factory.
- Entire meter assembly (electronic assembly) may be replaced in the field with a unit supplied from the factory labeled "Field Modification".

I/O Parameter Table

Pulse Input			Switch Port		
Ui	=	30 V	Ui	=	30 V
li	=	175 mA	li	=	175 mA
Pi	=	1 W	Pi	=	1 W
Ci	=	0	Ci	=	0
Li	=	0	Li	=	0
Open Collector Outputs			Sensor Power Output		
Ui	=	30 V	Ci	=	2.2 uF
li	=	175 mA	Li	=	0
Pi	=	1 W	Uo	=	6.93 V
Ci	=	0	Io	=	132 mA
Li	=	0	Po	=	0.19 W
Power Supply Input			mA Output		
Ui	=	30 V	Ui	=	30 V
li	=	175 mA	li	=	175 mA
Pi	=	1 W	Pi	=	1 W
Ci	=	0	Ci	=	0
Li	=	0	Li	=	0
Relay Outputs			RS-485 Connection		
Ui	=	30 V	Ui	=	5.9 V
li	=	1000 mA	li	=	225 mA
Pi	=	1 W	Pi	=	0.3 W
Ci	=	0.013 uF	Ci	=	0
Li	=	0	Li	=	0
Uo	=	11.55 V	Uo	=	5.88 V
Io	=	1 mA	Io	=	54 mA
Po	=	0.012 W	Po	=	0.08 W

Explosion-Proof Wiring (-HA and -EX Models)

Pulse Input Connections

Signal connections are made to a four-terminal connector. See *Connectors Labeling* on page 29. The following figures show connections to various flowmeter types.

There are no switches or jumpers to set up for the input. Setup and programming are performed through the CapTouch buttons or PC-based software.

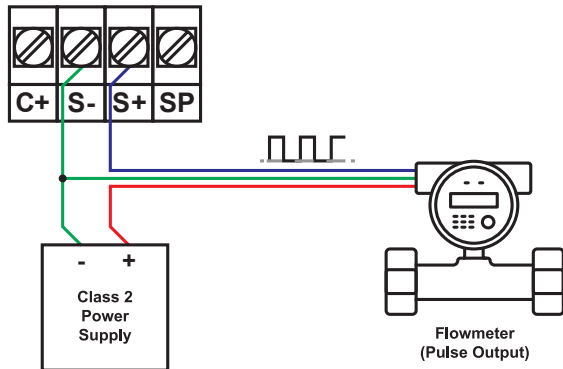

Figure 16. Flowmeter Powered by External Supply (Active)

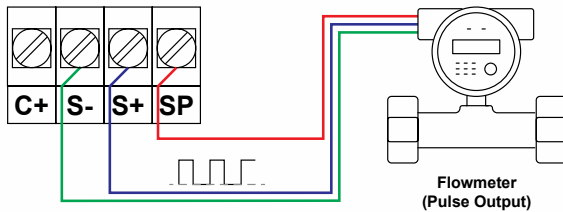

Figure 17. Flowmeter Powered by Internal Sensor Power (5 V @ 5 mA)

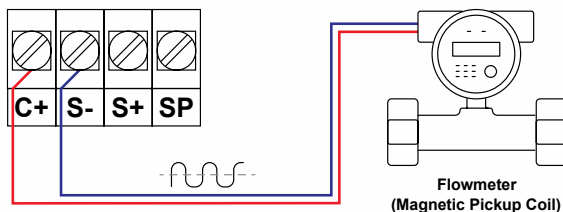

Figure 18. Self-Powered Magnetic Pickup Flowmeter (Coil)

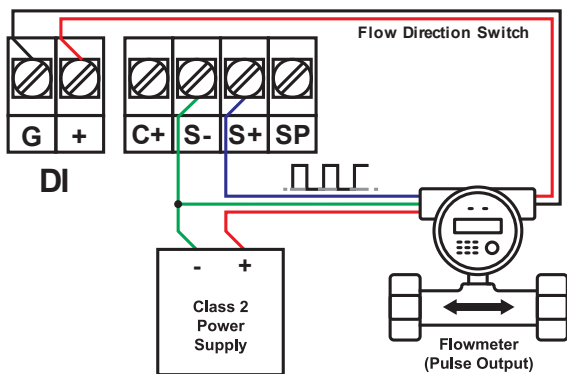

Figure 19. Bi-Directional Flowmeter Connections

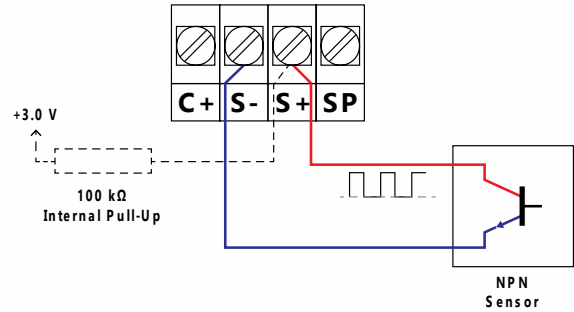

Figure 20. NPN Open Collector Input

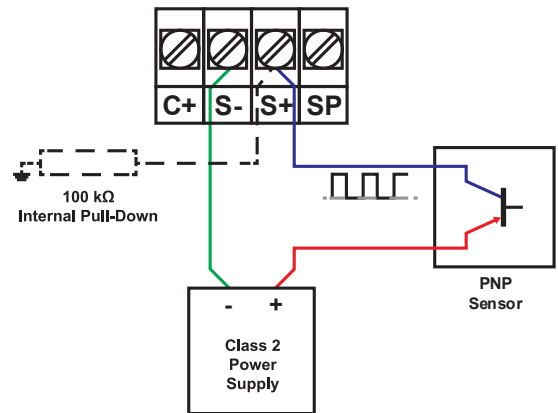

Figure 21. PNP Sensor with External Power

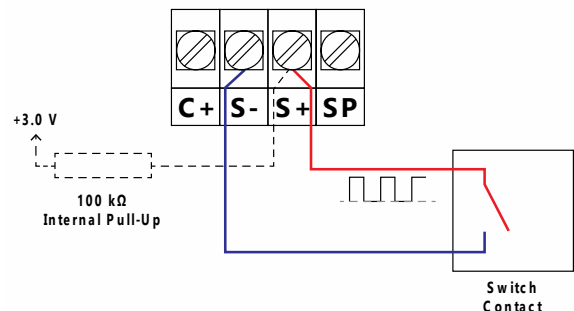

Figure 22. Switch Contact Input (Reed)

DC Power Connections

Models with battery power may optionally be connected to DC power and the battery will function as backup power when DC is lost. The same power supply may be used to power other circuits including a PNP-type sensor, however, to maintain input isolation, a separate power supply must be used to power the isolated 4-20 mA transmitter output.

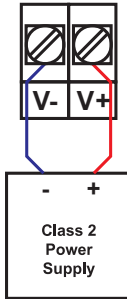

Figure 23. DC Power Connections

Digital Input Connections

A digital input is standard on the meter. This digital input is connected with a normally open contact across G and +, or with an active low signal applied to G and +.

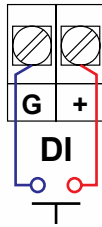

Figure 24. Digital Input Connections

RS-485 Serial Connections

The RS-485 three-wire serial connection is standard. The cabling used for an RS-485 serial communications network should always be a high-quality cable such as Belden 8162 or Alpha 6203C. Signal ground is always recommended.

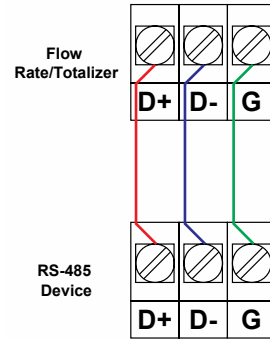

Figure 25. RS-485 2-Wire & Ground Serial Connections

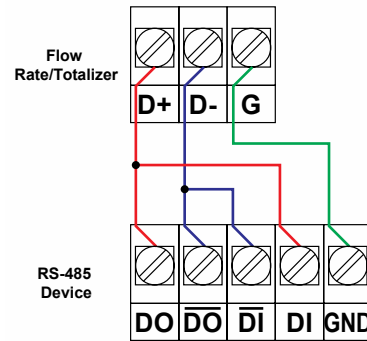

Figure 26. RS-485 4-Wire & Ground Serial Connections

IMPORTANT

- To connect the meter to the MeterView XL software using the RS-485 Modbus connection use a PDA8485 USB to RS-485 converter.

4-20 mA Output Connections

Connections for the 4-20 mA transmitter output are made to the connector terminals labeled 4-20 mA Output on *Figure 12*, page 33. The 4-20 mA output must be powered from an external power supply.

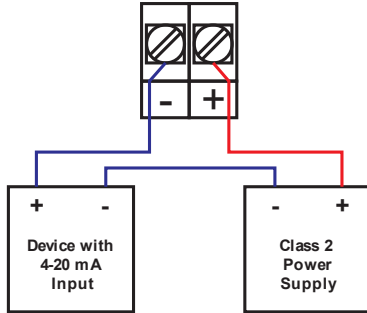

Figure 27. 4-20 mA Output Connections

Solid-State Relay Connections

Relay connections are made to two-terminal connectors. Each relay's C terminal is common only to the normally open (NO) contact of the corresponding relay.

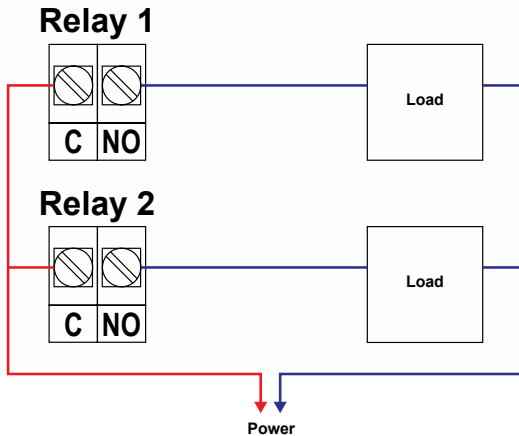

Figure 28. Solid-State Relay Connections

Open Collector Output Connections

Open collector output 1 and 2 connections are made to terminals labeled OC1 and OC2. Connect the alarm or pulse input device as shown below.

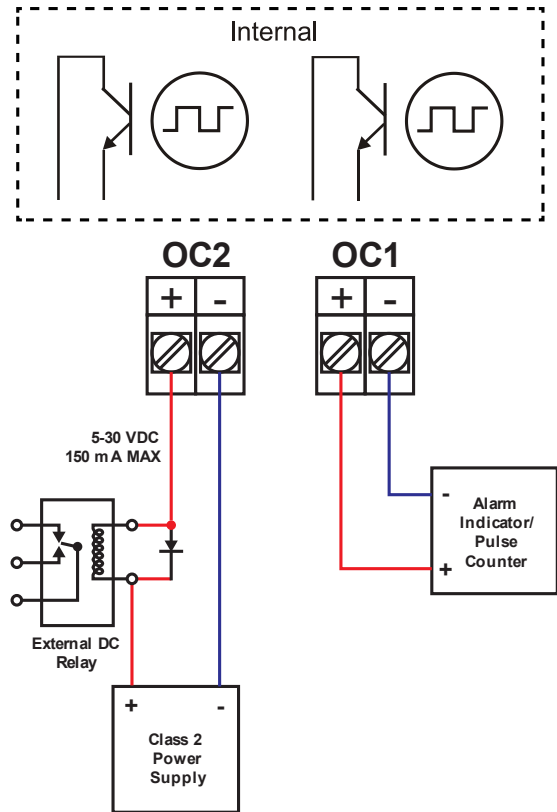

Figure 29. Open Collector Output Connections

Battery Replacement

Battery-equipped models have a battery charge monitor. When the battery is nearing the end of its capacity, the LOW BATTERY indicator on the screen will flash. The recommended replacement interval for models using the battery as a primary power source is determined by the power and feature usage, as shown on *page 20*. The battery should be replaced when the low battery indication is on the screen.

The total is backed up in non-volatile memory however it is recommended that the reading be manually backed up prior to changing out the battery.

WARNINGS

- DO NOT OPEN WHEN AN EXPLOSIVE ATMOSPHERE IS PRESENT.
- The replacement of the battery is intended to be done only when an explosive atmosphere is not present.
- Fire, explosion, and burns may result if not handled properly. Do not recharge, short circuit, crush, disassemble, heat above 100°C (212°F), incinerate, or expose contents to water.
- Battery disposal should be in accordance with applicable regulations, which vary by location. In many locations trashing of used batteries is forbidden and disposal is done through local battery disposal facilities. Spent batteries should be packaged in such a way as to prevent short circuits during handling and transport.



NOTICE: Battery may only be replaced with a new Precision Digital battery that is the same model supplied with the meter. Do not recharge battery. Do not replace with used battery.

- Remove cover of enclosure and disconnect display module from option module using the ribbon cable connector.
- Disconnect the battery connector plug from the socket on the option module.
- Remove the spent battery and prepare it for disposal.
- Install the new battery into the battery compartment and connect the battery connector plug into the socket on the option module as shown in *Figure 30*.
- Reconnect the option module to the display module and install enclosure cover.
- Resume operation.

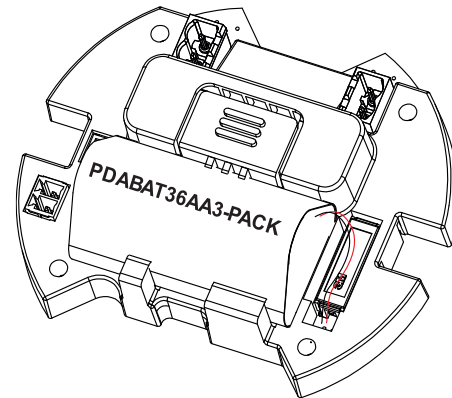

Figure 30. Battery Operation

Setup and Programming

The meter is factory calibrated prior to shipment to display 0.00 to 100.00, which corresponds to the pulse input. The calibration equipment is traceable to NIST standards.

Overview

There are no jumpers to set; setup and programming is done through the CapTouch buttons or the free MeterView XL PC-based software.



The meter may be powered via the micro-USB connection located on the display module for the purpose of programming only. The backlight will not work while the meter is powered via the USB connection.

CapTouch Buttons

The PD6938 is equipped with four capacitive sensors that operate as through-glass buttons so that it can be programmed and operated without removing the cover (and exposing the electronics) in a hazardous area.



These buttons can be turned off for security by selecting the *Off* setting on the switch located on the side of the display module, close to the Menu button.

To actuate a button, press one finger to the window directly over the marked button area. When the cover is removed, the CapTouch buttons can be used after the meter completes a self-calibrating routine (hand symbol  flashes). The sensors are disabled when more than one button is pressed, and they will automatically re-enable after a few seconds (hand symbol  off).

CapTouch Buttons Delay

The CapTouch have two modes of operation: *Normal* and *Delayed*. Use the Delayed mode to prevent accidental trigger of the buttons. In the Delayed mode, the buttons enter into a low sensitivity state (sleep) and they ignore quick button presses after 20 seconds of inactivity. To wake up the buttons, press and hold any button for more than 2 seconds, the buttons respond normally.

Turning Off CapTouch Buttons

The CapTouch buttons can be turned off for security by moving the slide switch located on the display module to the *Off* position.



CapTouch Button Tips & Troubleshooting

The CapTouch buttons are designed to work under any lighting condition and to protect against false triggering. If the CapTouch buttons are not needed during operation, they can be turned off (slide switch to *Off*).

- To remove cover with power applied (safe area only) or to clean the window, place your hand over the buttons; this will temporarily disable the CapTouch buttons to prevent inadvertent use.
- Keep the window clean.
- Tighten the cover securely.
- Use a password to prevent tampering.

IMPORTANT

- CapTouch buttons will not work if two or more buttons are detected as being pressed simultaneously. Be careful to avoid triggering multiple buttons or reaching across one button location to press another.

MeterView XL Programming Software



The fastest and easiest way to program the meter is using the free MeterView XL programming software. This software greatly simplifies the programming process and allows the user to save configuration files for later use.

The meter connects to the PC via a provided micro-USB cable and is powered by the USB connection, so no additional power is needed during programming.

To download the latest MeterView XL programming software and manual, visit prediq.com/meterviewxl.

⚠ WARNING

- The meter should only be connected to a computer while it is located in a safe area.



CapTouch Buttons and Status Indicators

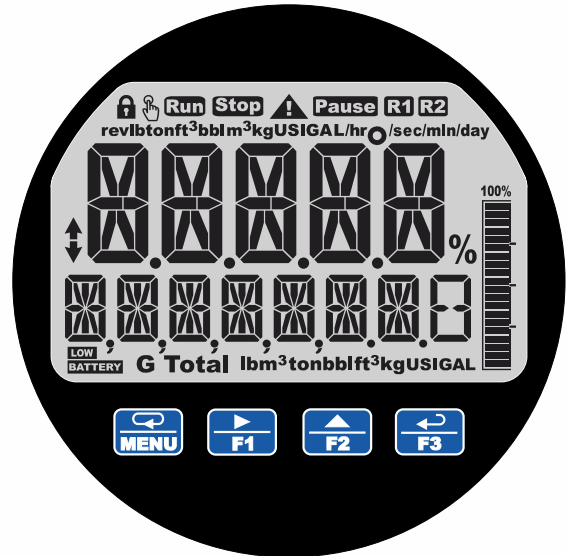

Buttons

Button	Description
	Menu
	Right Arrow/F1
	Up Arrow/F2
	Enter/F3

1. Press the **Menu** button to enter or exit the Programming Mode at any time.
2. Press or hold the **Right-Arrow** button to scroll forward through the menus, select digits during numeric programming, select characters during text programming, or decrement the value of a digit or character selected with the **Up-Arrow** button.
3. Press and hold the **Right-Arrow** button to zero or clear digits/characters while in data-entry mode.
4. Press or hold the **Up-Arrow** button to scroll backwards through the menus or to increment the value of a digit or character.
5. Press the **Enter** button to access a menu or to accept a setting or programmed digit/character value.

CAUTION

- Avoid touching more than one button at a time, otherwise the buttons become unresponsive and enter into a self-calibrating routine. This is indicated by the flashing hand symbol

Indicators

Indicator	State	Description
	Steady	Process trend arrows
	Flashing	Alarm Indicator
	Steady	Password protected
	Steady	Solid-state relay 1
	Steady	Solid-state relay 2
	Flashing	CapTouch buttons self-calibrating (wait)
	Steady	PV Bargraph
	Flashing	Alarm condition: Bargraph segment flashes on alarm
Total	Steady	Displaying Total
G Total	Steady	Displaying Grand Total
	Steady	Batch is running
	Flashing	Automatic batch control: Batch paused or start delayed
	Steady	Batch is stopped
	Steady	Batch is paused
	Flashing	Meter checking battery status
	Steady	Meter using battery power
	Flashing	Low battery

Display Functions & Messages

The meter displays various functions and messages during setup, programming, and operation. The following table shows the main menu functions and messages in the order they appear in the menu.

Display Functions & Messages	
Parameter	Action/Setting Description
INPUT TYPE	Select the input type (Flowmeter)
ACTIVE	Select for square wave
NPN	Select for NPN transistor
PNP	Select for PNP transistor
REED	Select for reed switch
COIL	Select for magnetic pickup coil
ACT HIGH	Select for high threshold square wave (see specs, page 20)
NPN HIGH	Select for high threshold NPN transistor (see specs, page 20)
NPN STRG	Select for stronger pull-up NPN transistor (see specs, page 20)
PNP HIGH	Select for high threshold PNP transistor (see specs, page 20)
KFACTOR	Enter the flowmeter's K-Factor
OUTPUT	Program the meter's available outputs
OPEN COLLECTR	Program the meter's open collector outputs
OUTPUT 1	Open collector 1 setup
OUTPUT2	Open collector 2 setup
DISABLE	Disable the open collector
PULSE	Program the open collector for pulse output
ALARM	Program the open collector for alarm output
TIMER	Program the open collector as a timer
TOT RST	Program the open collector for total reset
STPWATCH	Program the open collector to turn on while the stopwatch is running
MANUAL	Program the open collector to be always On or Off
MESSAGE	Select ON to display a message when open collector is on
RELAY	Program the meter's relay outputs
OUTPUT 1	Relay 1 setup
OUTPUT2	Relay 2 setup
DISABLE	Disable the relay
ALARM	Program relay for alarm functionality
SAMPLE	Program relay for sample functionality
TIMER	Program relay as a timer
ATCH	Program the relay for batch control functionality

Display Functions & Messages	
Parameter	Action/Setting Description
STPWATCH	Program relay to turn on while the stopwatch is running
MANUAL	Program the relay to be always On or Off
MESSAGE	Select ON to display a message when relay is on
RELAY INFO	View relay runtime and cycle count
4-20 mA	Program the meter's 4-20 mA output
RATE	Transmit a value based on the rate display
TOTAL	Transmit a value based on the total display
DISABLE	Disable the 4-20 mA output
CONTROL	Program manual or automatic operation for the outputs
OC 1	Open collector 1
OC2	Open collector 2
RELAY 1	Relay 1
RELAY2	Relay 2
4-20 mA	4-20 mA output
AUTO	Set selected output to automatic operation
MANUAL	Manually control selected output operation
ADVANCE	Program the meter's advanced features
ADV RATE	Advanced rate input programming
KFACTOR	Enter the flowmeter's K-Factor
SCALE	Scale the input frequency and the rate display for up to 32 points
PERCENT	Enter bargraph rate percent values
ADV TOTAL	Advanced total programming
COUNT	Program the totalizer functionality
LIMIT	Set the number of digits used for the total
8-DIGIT	Eight digits max (99,999,999)
13-DIGIT	Thirteen digits max (9,999,999,999,999) Requires top and bottom display to display entire number, total will roll over to zero when it exceeds the limit.
NEGATIVE	Enable counting negative values (Available only via front panel)
INITIAL	Set the total to start at a specific number
RESET	Enable or disable the ability to reset the total
MANUAL	Disable manual total reset (default: enabled)
TIME DAY	Enable total reset based on time of day (Up to 4 times), press Up key to change the day of the week, press Right key to change time.

Display Functions & Messages	
Parameter	Action/Setting Description
ADV GTOTAL	Advanced grand total programming
COUNT	Program the totalizer functionality
LIMIT	Set the number of digits used for the total
8-DIGIT	Eight digits max (99,999,999)
13-DIGIT	Thirteen digits max (9,999,999,999,999) Requires top and bottom display to display entire number, total will roll over to zero when it exceeds the limit.
NEGATIVE	Enable counting negative values (Available only via front panel)
INITIAL	Set the total to start at a specific number
RESET	Enable or disable the ability to reset the grand total
MANUAL	Enable manual grand total reset (default: disabled)
TIME DAY	Enable grand total reset based on time of day (Up to 4 times), press Up key to change the day of the week, press Right key to change time.
PERMLOCK	Set grand total as non-resettable (Once set, it cannot be changed)
CUTOFF	Set low-flow cutoff
DISABLE	Disable low-flow cutoff
ENABLE	Enable low-flow cutoff
GATE	Enter the gate settings
LOW GATE	Set low gate (this determines the rate display update)
HIGH GATE	Set high gate (this is used to display slow pulse rates)
FILTER	Set contact de-bounce filter
DISABLE	No filter, allows max frequency
FAST	Set filter to 1,000 Hz max
MEDIUM	Set filter to 240 Hz max
SLOW	Set filter to 100 Hz max
PASSWD	Set a password for the meter
MAIN	Program the main meter password
TOTAL	Program the total reset password
GTOTAL	Program the grand total reset password
DATALOG	Enter the data logger menu
LOG VIEW	View data logs
LOG SETUP	Set up data logs
HOURLY	Log every hour
DAILY	Log daily
INTERVAL	Set log interval
DAY TIME	Set log based on time of day (up to 4 times), select every day or any day of the week.

Display Functions & Messages	
Parameter	Action/Setting Description
EVENT	Set to log based on events: total reset, grand total reset, hold/unhold function, open collectors, and relays status.
LOG MODE	Select <i>Continue</i> when full (oldest log block replaced with newest logs) or <i>Stop</i> when full
LOG ERASE	Erase all data logs
COMM	Set up Modbus communications
SLAVE ID	Set the server ID (1 to 247)
BAUD RATE	Select the baud rate
TX DELAY	Set the transmit delay
PARITY	Select the parity: Even, Odd, None 1, or None 2
MODBUS TAG	Enter the Modbus tag
USER	Assign function keys / digital input
F1	Assign F1 function key
F2	Assign F2 function key
F3	Assign F3 function key
DI	Assign digital input
DISP FN	Set the function key or digital input to display a value
DISPLAY	Cycle max, min, rate, total, and grand total
RATE	Display the rate
TOTAL	Display the total
DISP GT	Display the grand total
PREV TOT	Display the previous total before the last total reset
PREV GT	Display the previous grand total before the last grand total reset
PERCENT	Display the rate's percentage
R UNITS	Display the rate, total, and grand total units
R TAG	Display the tags
DISPMIN	Display the minimum rate value
DISPMAX	Display the maximum rate value
MIN MAX	Display the minimum and maximum rate value
R FREQ	Display the input frequency
R mAOUT	Display the current mA output value
MENU FN	Set the function key or digital input to access a menu
RLY INFO	Go to relay information menu (INFO)

TIMERFN	Set the function key or digital input to start or stop a timer
STARTALL	Start all timers
STOPALL	Stop all timers
SSTPALL	Start or stop all timers
OC 1	Start/stop open collector 1 timer
OC2	Start/stop open collector 2 timer
RLY 1	Start/stop relay 1 timer
RLY2	Start/stop relay 2 timer
START	Start the selected timer output
STOP	Stop the selected timer output
STR--STP	Start or stop the selected timer output
SHORTCUL	Set a shortcut to timer settings Timer must be set up first
TIMR OC 1	Timer open collector 1 settings
TIMR OC 2	Timer open collector 2 settings
TIMER R 1	Timer relay 1 settings
TIMER R 2	Timer relay 2 settings
BATCHFN	Set the function key or digital input to batch control
START	Start a batch
STOP	Stop a batch
STR--STP	Start or stop a batch
PRESET	Preset batch amount
ALARMFN	Set the function key or digital input to acknowledge an alarm or access set points
ACK ALL	Acknowledge all active alarms
SETPOINL	Access all output set points
OC 1	Access open collector 1
OC2	Access open collector 2
RY 1	Access open relay 1
RY2	Access open relay 2
ACK	Acknowledge selected output active alarm
SETPOINL	Access selected output set point
OC 1 SET	Access open collector 1 set point
OC2 SET	Access open collector 2 set point
RLY 1 SET	Access relay 1 set point
RLY2 SET	Access relay 2 set point
SWATCHFN	Set the function key or digital input to activate stopwatch
START	Start the stopwatch
STOP	Pause/Stop the stopwatch
STR--STP	Start or stop the stopwatch (Resets on start)
DATALOG	Set the function key to a data log function
INTERVAL	Start/stop interval data log
MANUAL	Take a log record
ERASE	Erase all data logs

VIEW	View logs
SHORTCUL	Set a shortcut to log view, log setup, or log erase
HOLD FN	Set the function key or digital input to hold an output
HOLD OUT	Hold all outputs while F1-F3 or DI are active (pressed or on)
UNHOLD	Displayed when hold all outputs key is released
HL UNHLD	Hold/un-hold all outputs Press once to hold, press again to release after confirming with YES
OC 1+2	Hold/un-hold open collector outputs
RLY 1+2	Hold/un-hold relay outputs
mAOUT	Hold/un-hold 4-20 mA output
HOLD	Hold selected output
HL UNHLD	Hold or un-hold selected output
DISABLE	Disable function key or digital input
RST FN	Set the function key or digital input to reset a value
RESET	Reset min, max, or max/min rate value
R MINMAX	Reset max and min rate value
RST T	Reset the total
RST GT	Reset the grand total
RST TGT	Reset the total and grand total
HINT	Display hint text on key press and execute action on next key press
OFF	Turn the hint function off
ON	Turn the hint function on
SYSTEM	Program system settings
ADUTCAL	Calibrate the analog output
DEFAULT	Load factory defaults
BACKLITE	Enable/disable display backlight
ENABLE	Enable the backlight (default)
DISABLE	Disable the backlight
SENSPOW	Enable sensor power
CAPT TOUCH	Select CapTouch buttons mode
NORMAL	CapTouch normal (default)
DELAYED	CapTouch delayed
BATTERY	Access battery menu
DISPLAY	Access battery display settings
BACKLITE	Select backlite timeout
LCD SLEEP	Select LCD sleep timeout
INDICATOR	Display battery indicator
RS-485	Enable/disable RS-485 Modbus or program RS-485 enable interval
INFO	View meter software version and model; change the identifier tag
SFT	The software ID number
VER	The software version
MODEL	The meter model number

IITAG	The meter identifier tag Press <i>Enter</i> to edit tag
TIME	Set the system date & time
DISPLAY	Program the meter's display
UNITS	Change the display units within the selected unit class
RATE	Select the rate units
TOTAL	Select the total units
UMULT	Select the total units multiplier X1, 100 h, 1000 k, 1.0E^6 M
GTOTAL	Select the grand total units
GMULT	Select the grand total multiplier X1, 100 h, 1000 k, 1.0E^6 M
DECP	Change the decimal point location
RATE	Program the rate decimal point
TOTAL	Program the total decimal point
GTOTAL	Program the grand total decimal point
COMMA	Enable or disable the use of a comma on the bottom display
ENABLE	Enable comma (default)
DISABLE	Disable comma
BARGRAPH	Turn off or change the bargraph
RATE	Set the bargraph to display the rate percentage of a user-selected range
TOTAL	Set the bargraph to display the total percentage of a user-selected range
OFF	Turn the bargraph feature off
TOP	Select what to display on the top display
RATE	Display the rate
RATE+U	Display the rate and its units alternating
TOTAL	Display the total
TOTAL+U	Display the total and its units alternating
GTOTAL	Display the grand total
TAG	Display the tag
UNITS	Display the units
PRESET	Display the preset value
STOPWATCH	Display the stopwatch
TIMR OC1	Display open collector 1 timer
TIMR OC2	Display open collector 2 timer
TIMER R1	Display relay 1 timer
TIMER R2	Display relay 2 timer
MIN	Display minimum value
MAX	Display maximum value
MIN MAX	Display alternating min and max
TIME - 12H	Display time 12-hour format
TIME - 24H	Display time 24-hour format
DATE	Display date

BOTTOM	Select what to display on the bottom display
TOTAL	Display the total
TOTAL+U	Display the total and its units alternating
TOT+TAG	Display the total and its tag alternating
T+U+RU	Display the total, its units, and the rate units alternating
GTOTAL	Display the grand total
GT+UNITS	Display the grand total and its units alternating
GT+TAG	Display the grand total and its tag alternating
GT+U+RU	Display the grand total, units, and rate units alternating
RATE	Display the rate
RATE+TU	Display the rate and the total's units alternating
RATE+U	Display the rate and its units alternating
RATE+TAG	Display the rate and its tag alternating
R UNITS	Display the rate units
T UNITS	Display the total units
TAG	Display the tag
UNITS	Display the units
PRESET	Display the preset value
STOPWATCH	Display the stopwatch
TIMR OC1	Display open collector 1 timer
TIMR OC2	Display open collector 2 timer
TIMER R1	Display relay 1 timer
TIMER R2	Display relay 2 timer
MIN	Display minimum value
MAX	Display maximum value
MIN MAX	Display alternating min and max
TAG+RU	Display the tag and rate units alternating
TAG+TU	Display the tag and total units alternating
OFF	Disable the bottom display
R PCT	Display the rate's percentage of full scale
FREQ IN	Display the input frequency
mA OUT	Display the current mA output value
TIME - 12H	Display time 12-hour format
TIME - 24H	Display time 24-hour format
DATE	Display date

Main Menu

The main menu consists of all the meter's programmable functions: *Input*, *Output*, *Advanced*, and *Display*.

- Press **Menu** button to enter *Programming Mode* then press the **Right-Arrow** button to move forward through the menu and the **Up-Arrow** button to move back.
- Press **Menu** at any time to go back one level or press & hold to exit and return to *Run Mode*. Changes made to settings prior to pressing **Enter** are not saved.
- Changes to the settings are saved to memory only after pressing **Enter/F3** to confirm the setting or pressing **Enter/F3** at the **SAVE?** screen when available.

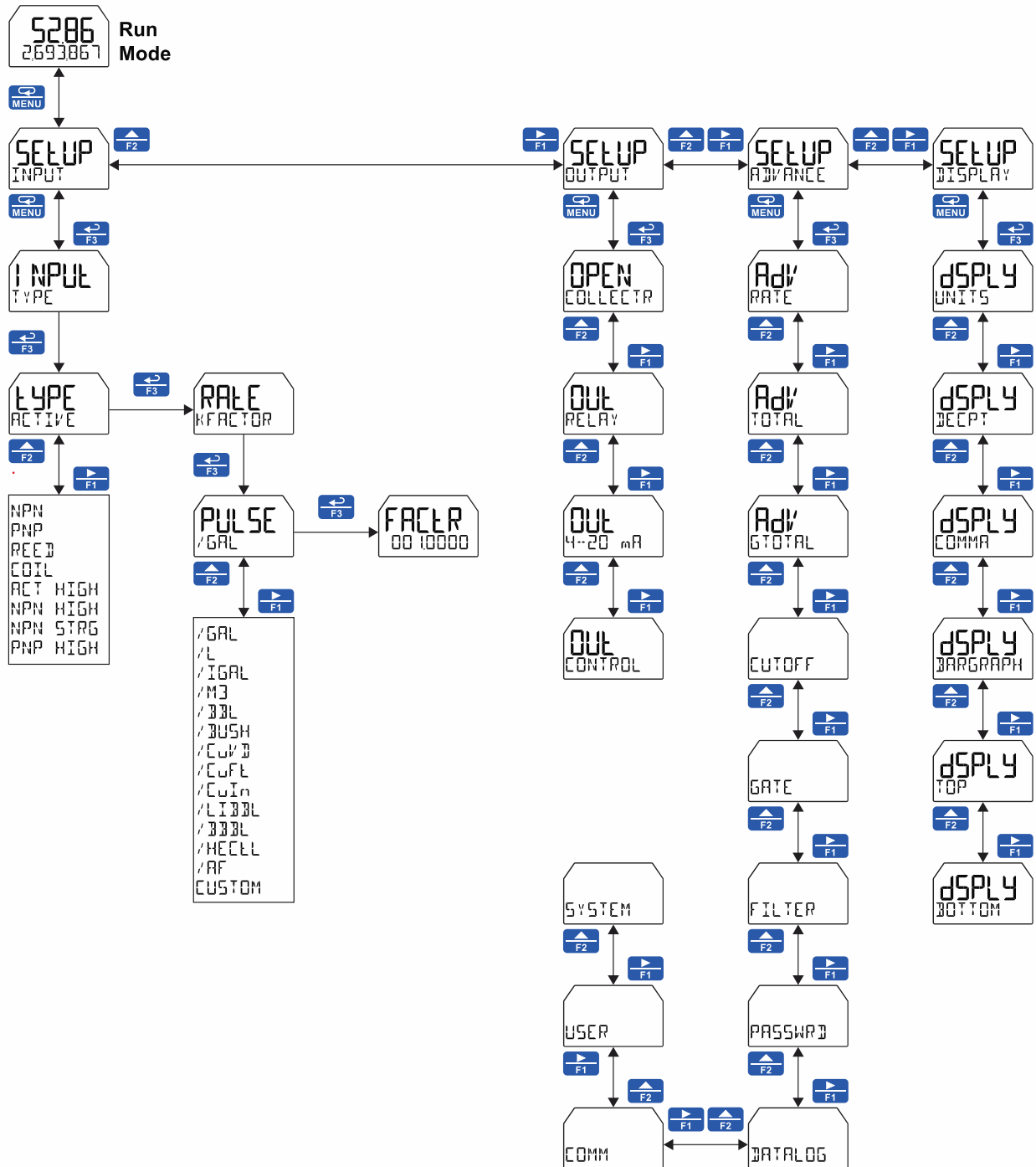

Note: The navigation returns to the top

Setting Numeric Values

The numeric values are set using the **Right** and **Up-Arrow** buttons.

1. Press **Right-Arrow** to select next digit and **Up-Arrow** to increment digit value. The selected digit will flash.
2. Press and hold **Up-Arrow** to auto-increment the display value. If you have made a mistake or would like to enter a new value, select the left-most digit, and press and hold the **Right-Arrow** button until all digits reset to zero.
3. Press the **Enter** button at any time to accept a setting or **Menu** button to exit without saving changes.

Note: the underscore in the graphic below is provided to show which digit would be flashing.

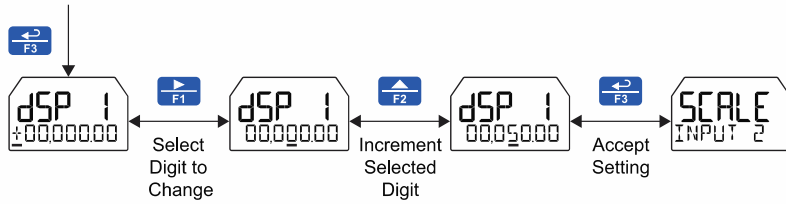

Note: Selected digit flashes. Flashing digit demonstrated using underscore.
Example: 00050000

Entering the K-Factor (KFACTOR)

The meter may be scaled using the *K-Factor*, or conversion factor, function. Most flowmeter manufacturers provide this information with the device. Enter the *K-Factor* (KFACTOR) menu and select the units defined with the K-Factor (example: pulses/gal), the decimal point with highest resolution possible, and program the K-Factor value. The meter automatically calculates the flow rate using the K-Factor value and the units selected. The rate can be displayed in any time-base and decimal point resolution selected in the Display menu.

▲ IMPORTANT

- Performing a K-Factor operation will override any scaling programming. Refer to *Scaling the Pulse Input (SCALE)* on page 50 for more information on these programming methods.

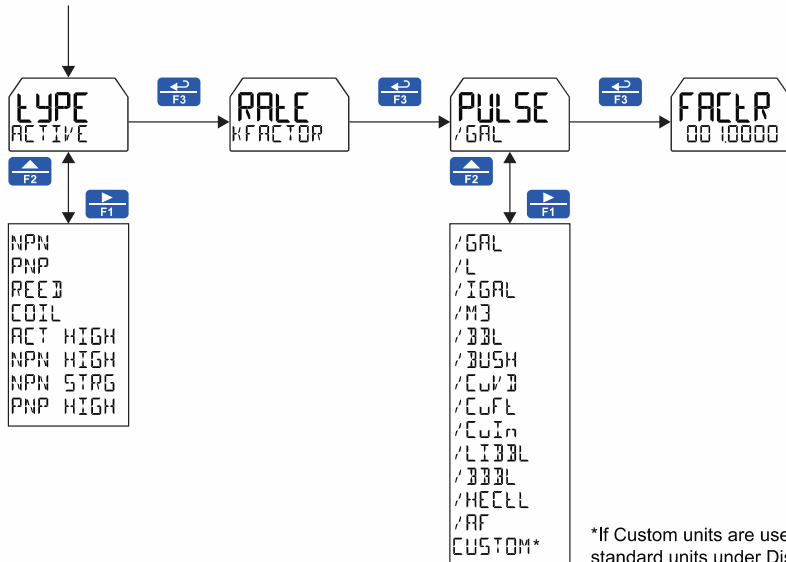

*If Custom units are used, then there is no conversion to standard units under Display menu. Only Custom units are available.

Scaling the Pulse Input (SCALE)

Scaling is an alternative calibration method used instead of K-Factor calibration. The multipoint scaling is a great way of improving the accuracy of a flowmeter application where output frequency and volume are known for various points of the flow rate.

- The meter is set up at the factory with a K-Factor of 1.000 pulses/gal. If it is necessary to use the multipoint scaling function (2-32 points) go to the *Advance* menu and enter the *Adv Rate* menu. After selecting Scale function in the Advance menu, the Scale menu is available in the *Setup Input* menu.
- The meter is factory calibrated prior to shipment to display the rate in gal/sec, which corresponds to the input frequency in pulses/sec. The calibration equipment is traceable to NIST standards.
- A calibrated signal source is not needed to scale the meter.

IMPORTANT

- Performing a *Scale* operation will override any *K-Factor* programming. Refer to Entering the K-Factor (KFACTOR) on page 49 for more information on these programming methods.

Enter the *Rate Scale* menu to scale the meter to display the pulse input.

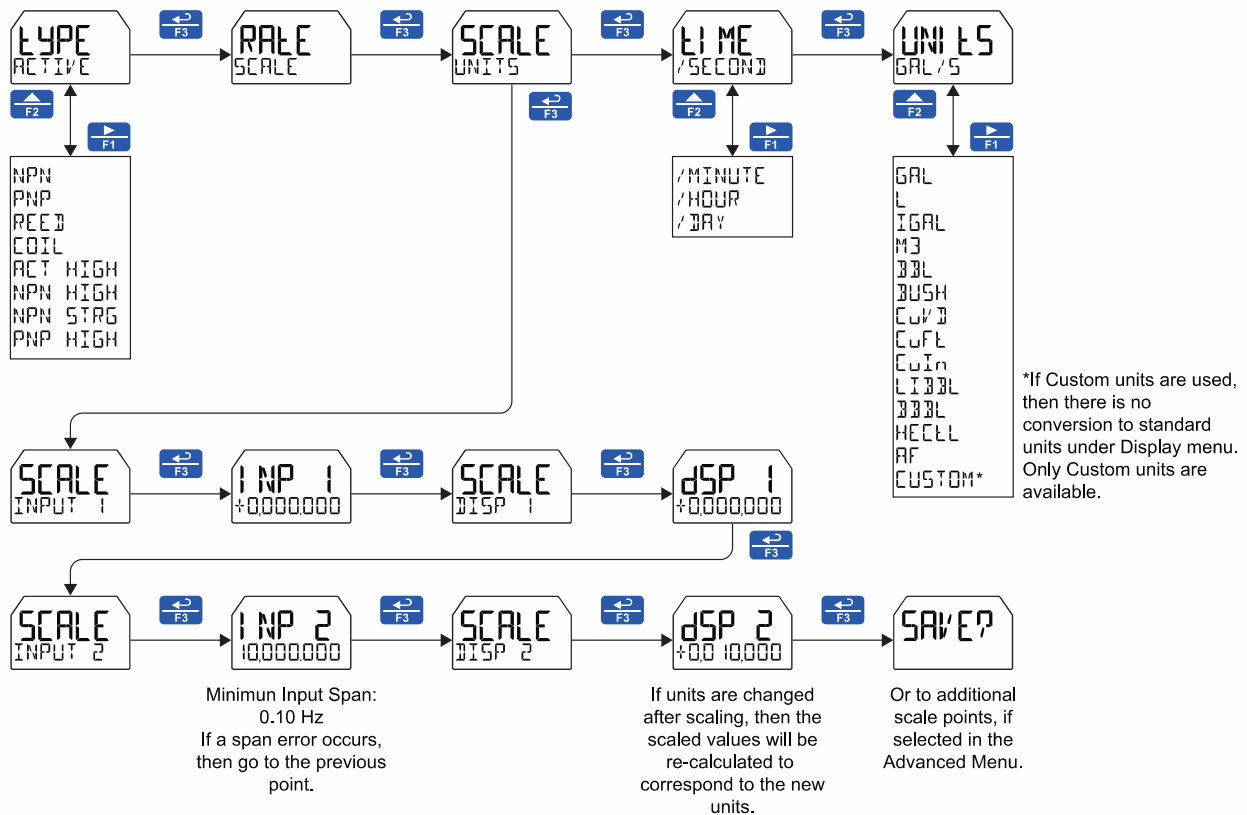

IMPORTANT

- **Bi-Directional Flow**
The meter can be set up to process bi-directional flow, refer to Bi-Directional Flow on page 75 for details.

Available Engineering Units

The meter has preprogrammed rate and time base units. The following are the available units to choose from:

Rate Time Bases (TIME)	
/SECOND	Units per second
/MINUTE	Units per minute
/HOUR	Units per hour
/DAY	Units per day

Rate Units (RATE)	
GAL / (T)	Gallons per time unit (T)
L / (T)	Liters per time unit (T)
IGAL / (T)	Imperial gallons per time unit (T)
M3 / (T)	Cubic meters per time unit (T)
BBL / (T)	Barrels per time unit (T)
BUSH / (T)	Bushels per time unit (T)
cuyd / (T)	Cubic Yards per time unit (T)
cufL / (T)	Cubic Feet per time unit (T)
cuin / (T)	Cubic Inches per time unit (T)
L, BBL / (T)	Liquid barrels per time unit (T)
BBBL / (T)	Beer barrels per time unit (T)
HECLL / (T)	Hectoliter per time unit (T)
AF / (T)	Acre-Foot per time unit (T)
CUSTOM /	Custom unit per time unit (T)

▲ IMPORTANT

- Use custom units for engineering units not listed or for units in other languages.

Volume Units

Volume Units (VOLUME)	
GAL	Gallons
L	Liters
IGAL	Imperial Gallons
M3	Cubic Meters
BBL	Barrels
BUSH	Bushels
cuyd	Cubic Yards
cufL	Cubic Feet
cuin	Cubic Inches
L, BBL	Liquid barrels
BBBL	Beer barrels
HECLL	Hectoliter
AF	Acre-Foot
CUSTOM	Custom Unit

Setting Custom Units (CUSTOM)

When the desired unit class or unit of measure within a class is not available, a custom unit may be programmed. Select the CUSTOM menu (or CUSTOM unit within a unit class) to enter a custom unit name.

Text values are set using the **Right** and **Up-Arrow** buttons. Press **Right-Arrow** to select next character and **Up-Arrow** to increment character value. The selected character will flash. Press and hold the **Up** or **Right-Arrow** buttons to auto-increment or decrement the character. Press **Enter** to accept the character.

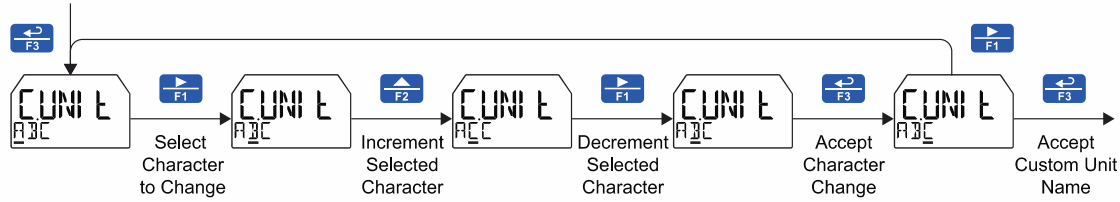

Notes:

- Press and hold the **Right-Arrow** while no character is being edited to erase all characters to the right of the flashing character
- Press and hold **Up** or **Right-Arrow** to auto-increment or decrement a selected character.
- All text values, including tags and alarm messages, are set in a similar fashion.

Setting the Display Features (DISPLAY)

The meter's display functions may be programmed using the *Display* menu. This menu consists of the following submenus: *Units*, *Decimal Point*, *Comma*, *Bargraph*, *Top*, and *Bottom*.

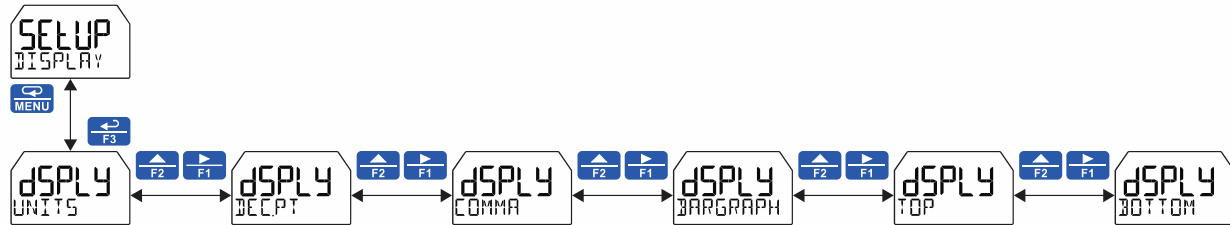

Changing the Engineering Units (UNITS)

It is possible to change the engineering units without the need to re-scale the meter. When selecting a new unit from within the DISPLAY menu (e.g. changing from gallons (GAL) to liters (L)), the meter will automatically convert the display values to display the new unit. Enter the UNITS menu, select a new unit of measure from the list of predefined units, and press the **Enter** button. If entering a custom unit (CUSTOM), a custom conversion factor needs to be entered.

Changing the Decimal Point (DECP T)

The decimal point may be set with up to seven decimal places or with no decimal point at all.

Pressing the **Right-Arrow** moves the decimal point one place to the right until no decimal point is displayed, and then it moves to the left most position. Pressing the **Up-Arrow** moves the decimal point one place to the left.

If the dual-scale level feature is selected, the decimal point selections for PV1 & PV2 are enabled.

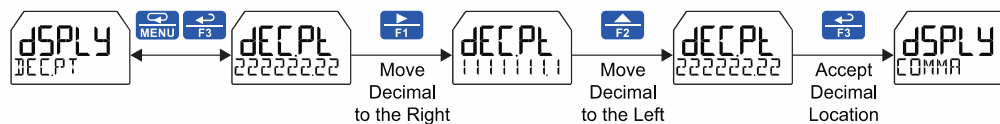

Enabling or Disabling Commas on the Bottom Display (COMMA)

The bottom display is set to show a comma separating the thousands and millions place by default if a numeric value is being displayed. This feature can be disabled or enabled using the *Comma* menu.

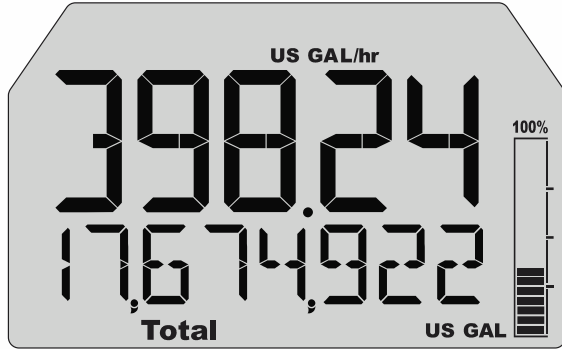

Display Capabilities Optimization (TOP and BOTTOM)

Display Configuration Examples

The meter's dual-line display can be setup in multiple ways to provide an extremely informative view of the process variable being monitored. The following graphics show typical configurations:

Top Display: Toggle Flow Rate and Rate Units
Bottom Display: Toggle Total Flow and Total Units

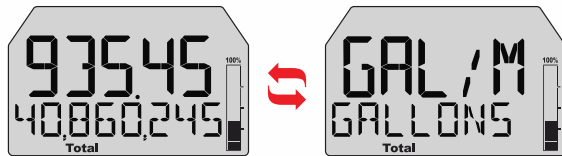

Note: To display units as GALLONS, select custom units and enter the desired text.

Top Display: Flow Rate
Bottom Display: Toggling Between Units and Tag

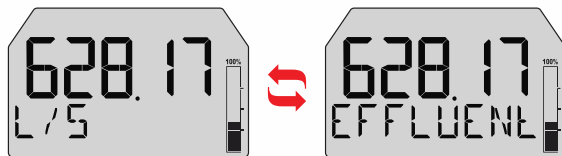

Dual-Scale Mode:

Top Display: Toggle Rate and GPM Units

Bottom Display: Toggle Rate and CFM Units

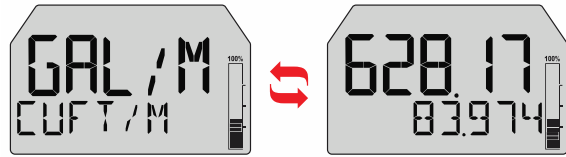

Top Display: Maximum Value
Bottom Display: Process Value

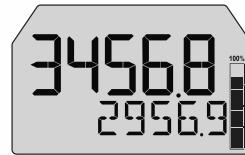

Using 13 Digits to Display Total

The top and bottom displays can be set up to display a 13-digit total.

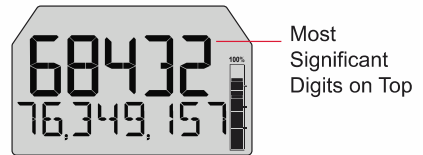

Note: The number above should be read as 6,843,276,349,187

Configuring the Display (TOP and BOTTOM)

The display is configured using the TOP and BOTTOM menus in the DISPLAY menu.

The top display (TOP) can display:

- Rate
- Rate and its units alternating
- Total
- Total and its units alternating
- Grand Total
- Tag
- Units
- Preset batch value
- Stopwatch
- Open Collector 1 or 2 Timer
- Relay 1 or 2 Timer
- Minimum Value, Maximum Value, or Both
- Time 12-hour or 24-hour format
- Date

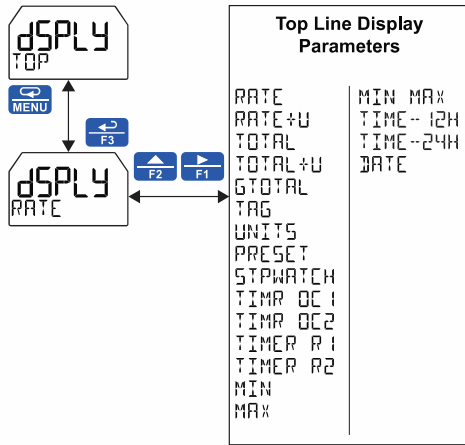

The bottom display (BOTTOM) can display:

- Total
- Total and its units alternating
- Total and tag alternating
- Total, its units, and rate units alternating
- Grand total and its units alternating
- Grand total and tag alternating
- Grand total, units, and rate units alternating
- Rate
- Rate and the total's units alternating
- Rate and its units alternating
- Rate and tag
- Rate units
- Total units
- Tag
- Units
- Preset batch value
- Stopwatch
- Open Collector 1 or 2 Timer
- Relay 1 or 2 Timer
- Minimum Value, Maximum Value, or Both
- Tag and rate units
- Tag and total units
- Off (Blank)
- Rate percent
- Input frequency
- mA output
- Time 12-hour or 24-hour format
- Date

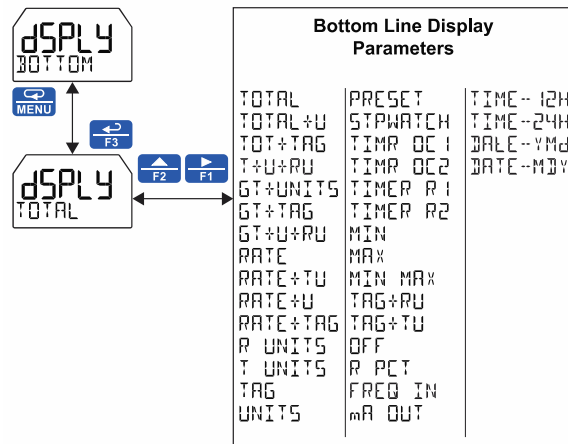

Programming the Bargraph (BARGRAPH)

The ProtEX+ Rate/Totalizers are equipped with a bargraph display for applications where a visual representation of the rate or total's percentage of full scale is desirable. This feature can be changed to represent either rate, a percentage of the rate, total, or it can be disabled, using the *Bargraph* menu (BARGRAPH). If the bargraph is set to represent total, the total full scale will need to be set.

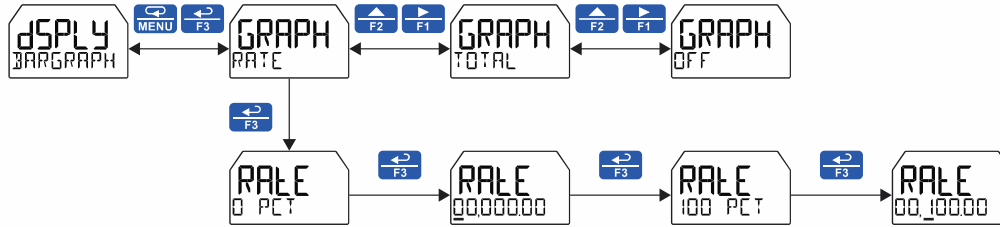

Programming the Outputs (OUTPUT)

All models come with two open collectors. Depending on the model purchased, the meter may include two solid-state relays, and one 4-20 mA output. The *Output* menu will only show options for the available outputs. See *Ordering Information* on page 13 for details.

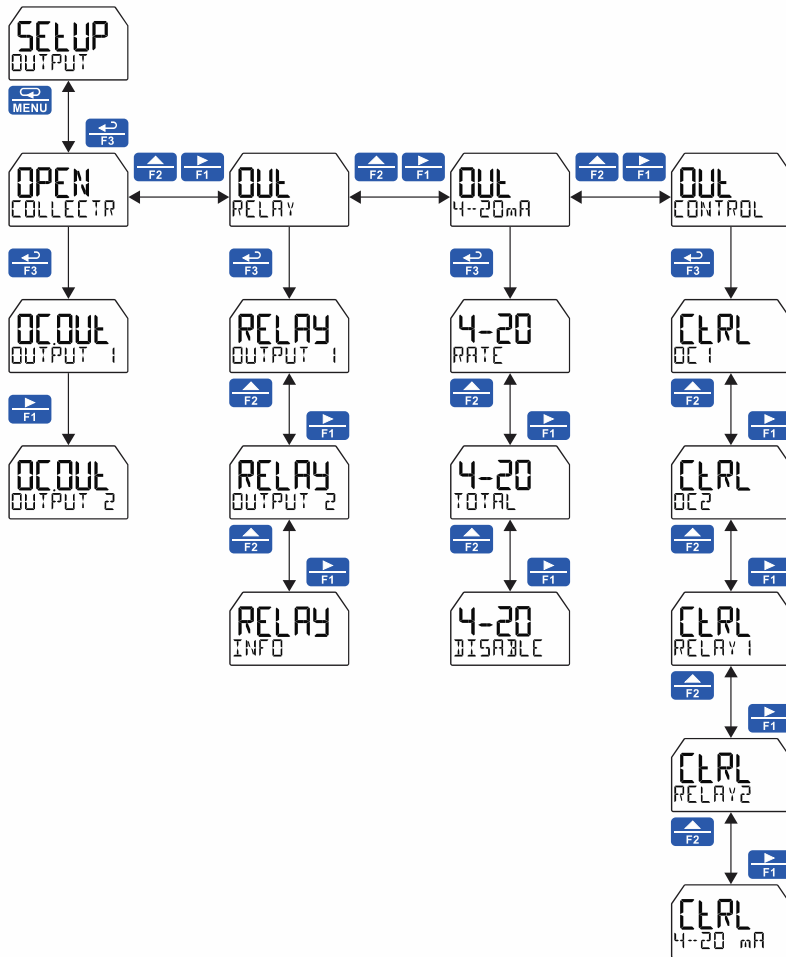

Open Collector Outputs (OPEN COLLECTR)

The meter is equipped with two NPN open collector outputs that may be set up for pulse outputs, alarms, timed pulses, total reset, or disabled.

Pulse outputs can be set to transmit the rate, total, or grand total. Output 2 may be used to generate a quadrature output based on the other open collector output. An output test mode is also selectable to generate pulses at a constant programmable frequency.

Alarms are available based on the rate value or the digital input. The alarm status will show on the display even if the output is not wired.

A timer output (TIMER) turns the open collector on and off at the specified time intervals. The timer can be set as single-shot or continuous timer.

A total reset output generates a pulse whenever the total is reset, regardless of the reset method used. The On time is programmable between 0 and 9,999 seconds.

The stopwatch output (STPWATCH) allows the open collector to be manually activated by starting the stopwatch. The stopwatch count can be displayed on the top or bottom display.

The output may be disabled by selecting **DISABLE**.

The Open Collector Outputs are programmed in the following manner:

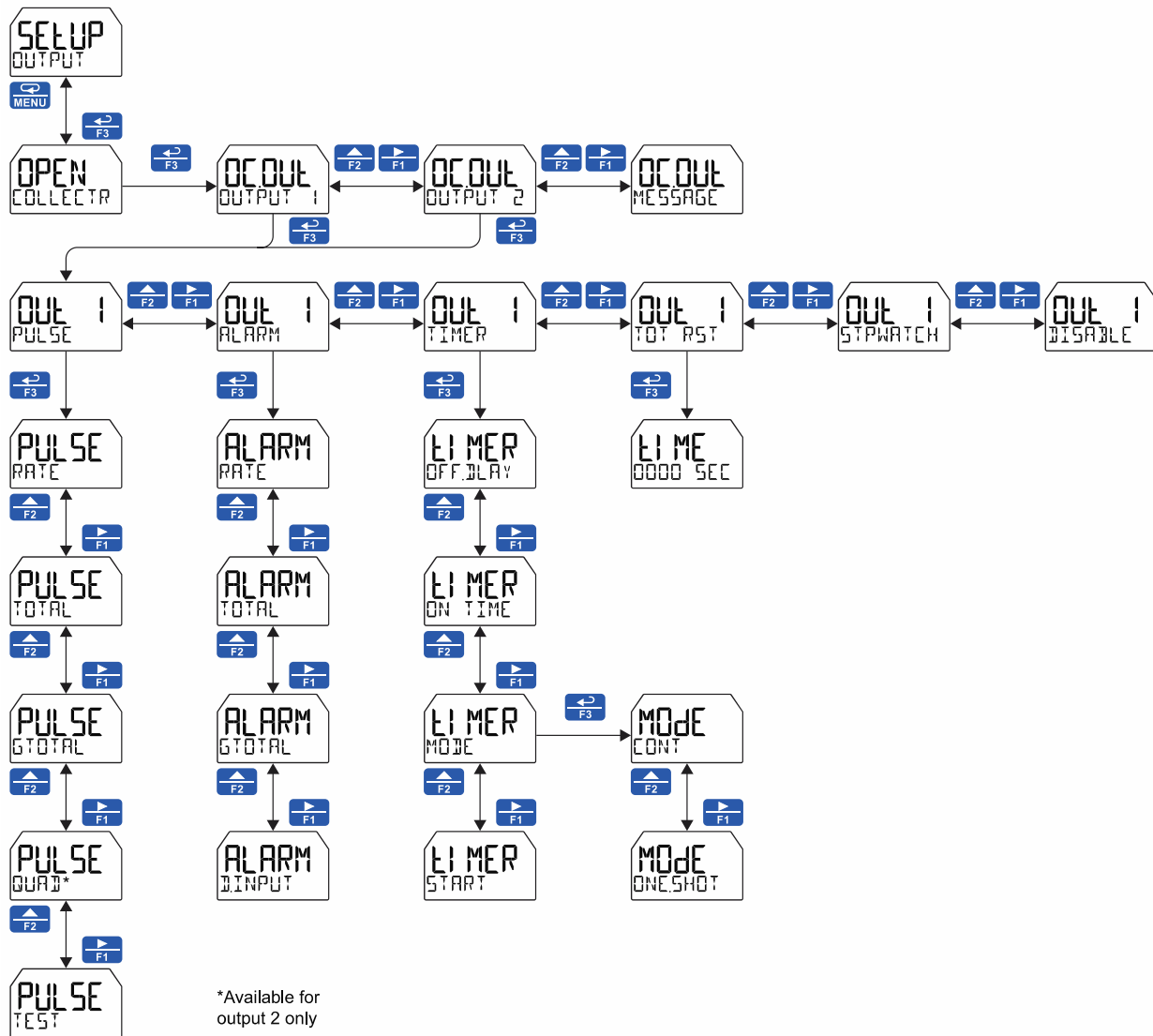

Pulse Output (PULSE)

Pulse outputs may be assigned to output the rate, total, or grand total at a programmable factor. If the output is assigned to rate, the factor is a multiplier that determines the number of pulses generated based on the rate. For example, if the meter display shows 100 gallons/second and the factor is set to 2, the number of pulses generated per second would be 200. If the output is assigned to total or grand total, the k-factor corresponds to the number of pulses generated per unit of measure. For example, if the k-factor is 0.001 and the units are gallons, one pulse will be generated for every 1,000 gallons. The maximum frequency is 2,000 Hz.

Setting output 2 to quadrature will duplicate the other open collector output, but lag by 90 degrees out of phase. The other output should be programmed as desired for the quadrature output function and must be a pulse (PULSE) output selection. The quadrature maximum frequency for both outputs is 1000 Hz.

The TEST option will output a fixed number of pulses per second based on the FREQ value entered.

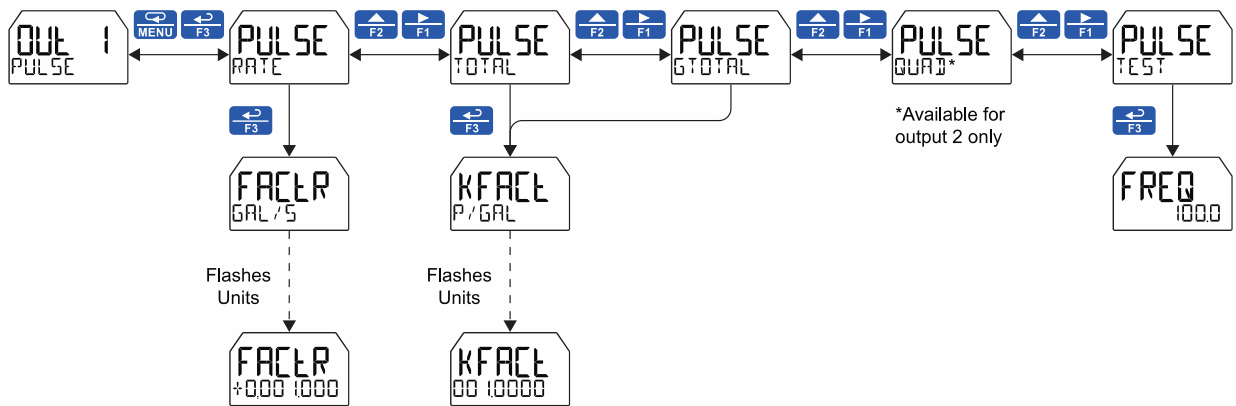

Alarm (ALARM)

Alarm outputs may be assigned to the rate, total, grand total, or the digital input. When assigned to the rate, the alarm may be set as either a high alarm or a low alarm. Alarm actions (AUTO, AUTOMAN, LATCH, L--CLEAR) determine how and when the alarm should be reset. They operate as follows:

- **Automatic (AUTO):** Alarm will reset automatically once the alarm condition has cleared.
- **Automatic/Manual (AUTOMAN):** Alarm will reset automatically once the alarm condition has cleared but can also be reset using the **Enter** (ACK) button (or whichever function key is set to acknowledge) at any time.
- **Latching (LATCH):** Alarm must be reset manually and can be done so at any time. Press the **Enter** (ACK) button at any time to clear the alarm.
- **Latching with Reset after Clear (L--CLEAR):** Alarm must be reset manually and can only be done so after the alarm condition has cleared. Press the **Enter** (ACK) button after the alarm condition has cleared to reset the alarm.

If the alarm is set to rate, a set and reset point must be programmed. The set point is the display value at which the alarm will turn on and the reset point is the display value at which the alarm will turn off. If the set point is lower than the reset point, the alarm will be a low alarm; if the set point is higher than the reset point, the alarm will be a high alarm. The digital input alarm will trigger whenever the digital input is triggered.

For both the rate and digital input alarms, a delay before the alarm is turned on or off may be set, as well as a fail-safe feature which reverses the on/off operation of the open collectors.

Alarm states will be displayed on the meter even if no open collector output is physically connected. These may include a red LED backlight, flashing the rate value (rate alarm only), a programmable alarm message, an alarm indicator ▲, and flashing bargraph segment.

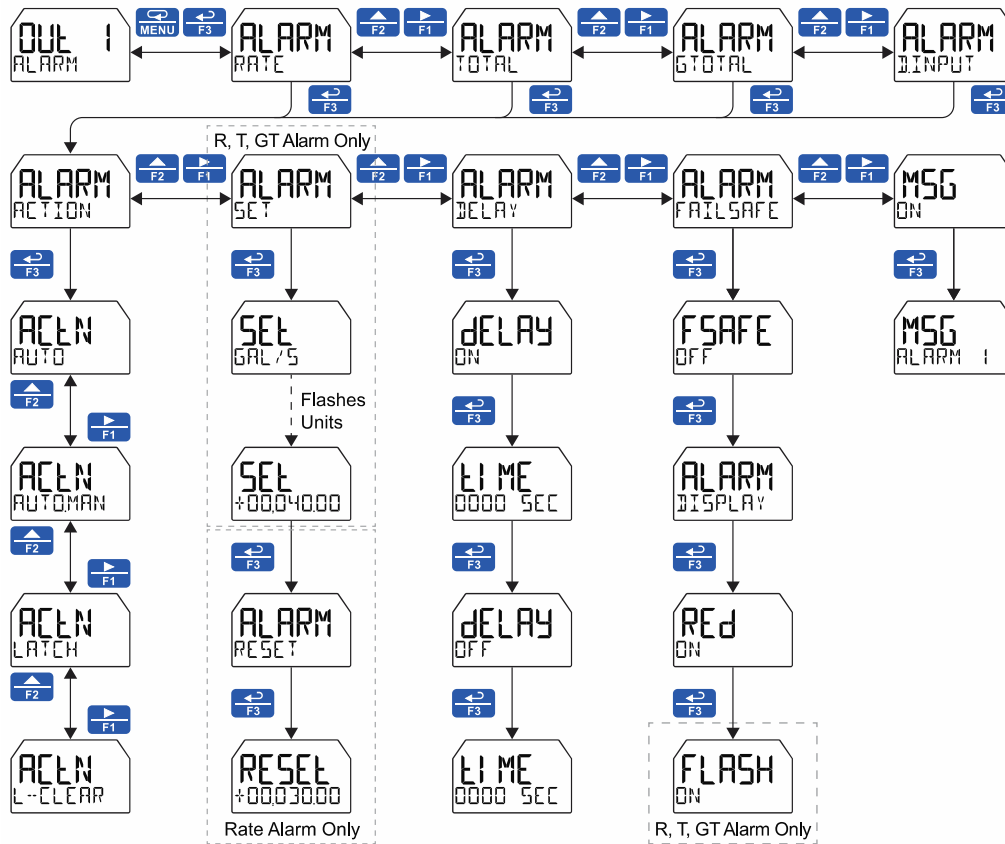

Flashing Red Alarm (RED)

The last two lines in the preceding menu flow chart show how to program the display to turn red, flash, and display a message when an alarm occurs.

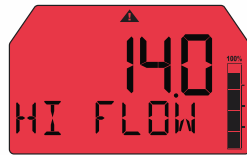

Alarm 1 is High Alarm

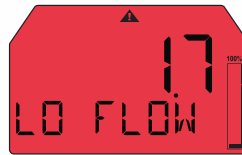

Alarm 2 is Low Alarm

Timer (TIMER)

The timer output may be set to generate the timed pulse only once (ONESHOT) or continuously (CONT).

The timer output produces a constant width pulse at a constant frequency, if set as continuous timer. Program the *Off Delay* (OFF DELAY) from 1 second to 99 hours 59 minutes and 59 seconds. This is the time it takes from selecting START to turning on the output and for how long the output is off in continuous mode.

Program the *On Time* (ON TIME) for the active low pulse from 1 second to 99 hours 59 minutes and 59 seconds (pulse width). This is the period of time for which the output will remain on.

Select *Start* (START) to begin outputting the constant timed pulse.

Select *Stop* (STOP) to end outputting the constant timed pulse.

Function keys or the digital input may be assigned to start and stop timer functions (see the USER menu in the *Advanced Menu*).

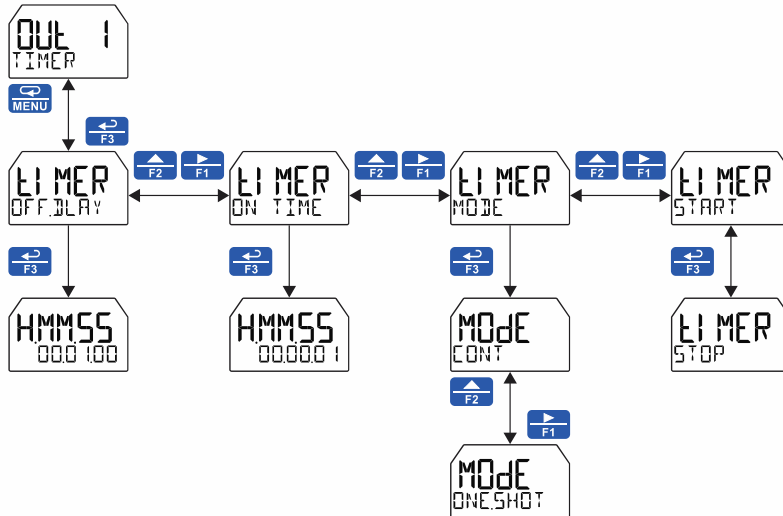

Stopwatch (STPWATCH)

The stopwatch function may be used to manually run and control a process for a specific time interval up to 99 hrs., 59 min, and 59 seconds. The stopwatch function may be assigned to any open collector. There are three settings needed to use the function effectively.

1. Assign stopwatch to either top or bottom display
2. Assign the open collector to control the process (on/off)
3. Assign a function key or digital input to start/stop the stopwatch

Application Example

To maintain consistency of a product, it is necessary to take and test samples at different times throughout the day. The stopwatch function is used to open and close a solenoid valve to know the exact amount of time needed to complete the desired sample. Once this is determined, the timer function can be used to automatically take a sample (batch) based on the time determined using the stopwatch function.

Setup: Assign the following to *Stopwatch Function*

- Bottom display
(see pages 52 & 54 for details how to change the display)
- Relay 1
(see pages 55 & 61 how to change Open Collector and Solid-State Relay functionality)
- F3: Start/Stop
(see pages 77 & 81 for details on how to change the function keys)

Procedure

- Press F3 to start the stopwatch; relay 1 turns on and the process starts running.
- Press F3 to stop the stopwatch; relay 1 turns off and the process stops.
- The bottom display indicates the time it took to complete the sample.

Solid-State Relay Outputs (RELAY)

The meter is optionally equipped with two solid-state relays that may be set up for alarms, sample, timer, batch control, or stopwatch. Alternatively, they may be disabled.

Alarms are available based on the rate, total, grand total, or the digital input. The alarm status will show on the display even if the output is not wired.

Sample will engage the relay for a programmed period of time when either the total or the grand total have reached a programmed amount.

A timer output (TIMER) turns the relay on and off at the specified time intervals. The timer can be set as single-shot or continuous timer.

For use in batch control applications, the meter relays must be set to batch. This will enable the batch control features of the meter.

The stopwatch output (STOPWATCH) allows the relay to be manually activated by starting the stopwatch. The stopwatch count can be displayed on the top or bottom display.

The output may be disabled by selecting **DISABLE**.

CAUTION

- During setup, the relays do not follow the input and they will remain in the state found prior to entering the *Relay* menu.
-

Relay Menu

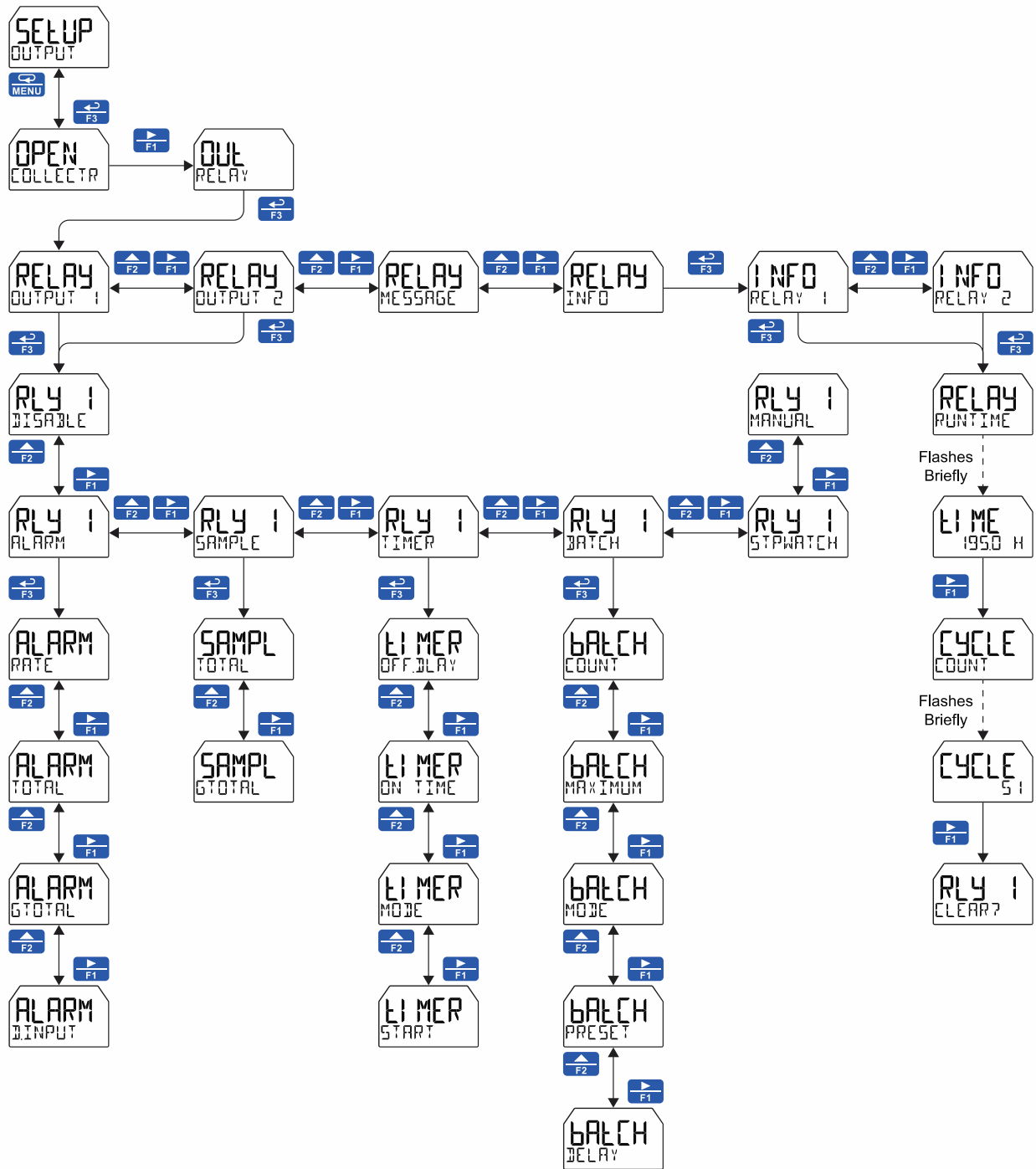

Alarm (ALARM)

Alarm outputs may be assigned to the rate, total, grand total, or the digital input. When assigned to the rate, the alarm may be set as either a high alarm or a low alarm. Alarm actions (AUTO, AUTOMAN, LATCH, L--CLEAR) determine how and when the alarm should be reset. They operate as follows:

- **Automatic (AUTO):** Alarm will reset automatically once the alarm condition has cleared.
- **Automatic/Manual (AUTOMAN):** Alarm will reset automatically once the alarm condition has cleared but can also be reset using the **Enter** button (or whichever function key is set to acknowledge).
- **Latching (LATCH):** Alarm will **not** reset automatically even if the alarm condition has cleared. Press the **Enter** button at any time to acknowledge the alarm.
- **Latching with Reset after Clear (L--CLEAR):** Alarm must be reset manually and can only be done so after the alarm condition has cleared. Press the **Enter** (ACK) button after the alarm condition has cleared to reset the alarm.

If the alarm is set to rate, a set and reset point must be programmed. The set point is the display value at which the alarm will turn on and the reset point is the display value at which the alarm will turn off. If the set point is lower than the reset point, the alarm will be a low alarm; if the set point is higher than the reset point, the alarm will be a high alarm. If the alarm is set to total or grand total, only a set point needs to be programmed. The digital input alarm will trigger whenever the digital input is triggered.

For all alarms, a delay before the alarm is turned on or off may be set, as well as a failsafe feature which will inverse the on/off programming.

Alarm states will be displayed on the meter even if no relay output is physically connected. The alarm indicator ▲ will display as well as optional red LED backlight, flashing rate, total, or grand total value (rate, total, or grand total alarms only), and a programmable alarm message.

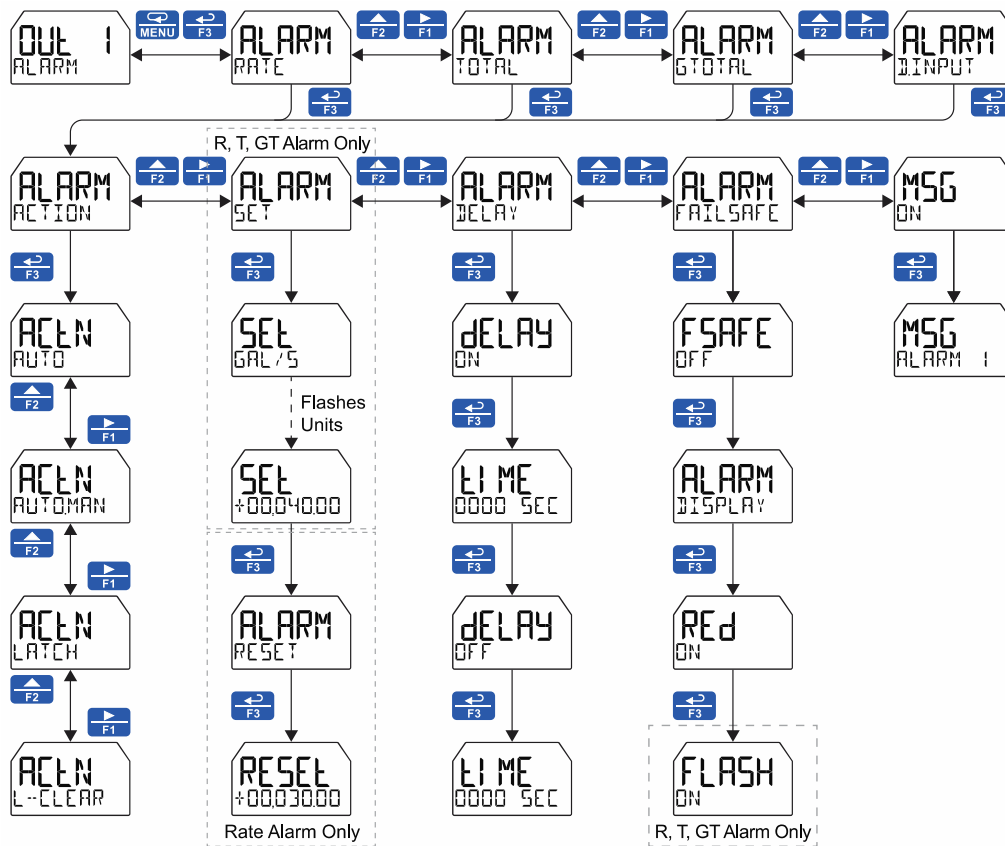

Sample (SAMPLE)

A relay set to sample will trigger when the total or grand total value has incremented by a programmed amount. The relay can be programmed to stay on for a specified amount of time.

For example: if a relay is set to sample the total with a **COUNT** of 1,000 and a **TIME** of 10 seconds, the relay will engage for 10 seconds whenever the total has incremented by 1,000 (e.g. 1000, 2000, 3000).

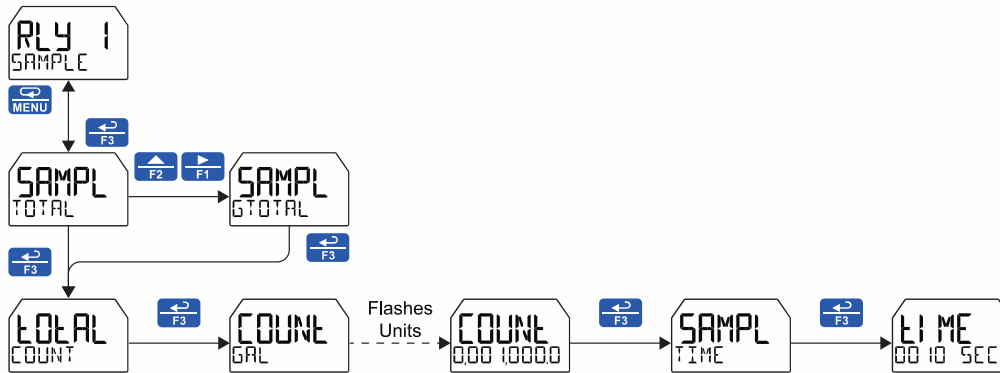

Timer (TIMER)

The timer output may be set to generate the timed pulse only once (**ONESHOT**) or continuously (**CONT**). The timer output produces a constant width pulse at a constant frequency, if set as continuous timer.

Program the *Off Delay* (**OFF DELAY**) from 1 second to 99 hours 59 minutes and 59 seconds. This is the time it takes from selecting **START** to turning on the output and for how long the output is off in continuous mode.

Program the *On Time* (**ON TIME**) for the active low pulse from 1 second to 99 hours 59 minutes and 59 seconds (pulse width). This is the period of time for which the output will remain on.

Select *Start* (**START**) to begin outputting the constant timed pulse. Select *Stop* (**STOP**) to end outputting the constant timed pulse. Function keys or the digital input may be assigned to start and stop timer functions (see the **USER** menu in *Advanced*).

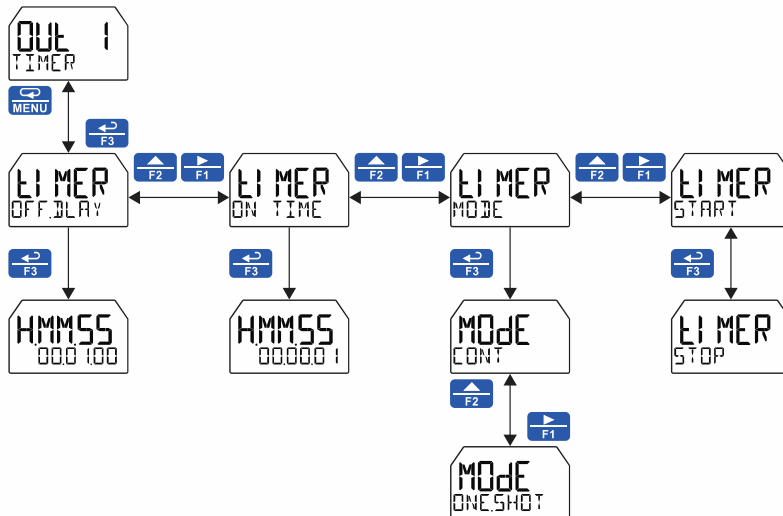

Batch Control (BATCH)

Selecting batch control for relay 1 enables the batching features on the meter. The top display is changed to show the total and the bottom display is changed to display the preset batch amount. The function keys are changed so that F1 starts a batch, F2 opens the preset menu to allow the preset value to be changed, and F3 stops the currently running batch. Enabling batch control for relay 1 allows access to the batch menu under relay 2 (this menu does not appear by default).

Batch Control Relay 1

The batch total can be set to count UP or DOWN. The batch MAXIMUM is the max preset amount that can be batched. Batching can be set to either manual or automatic operation (MANUAL or AUTO). If setting batching to automatic, a delay before the next batch is started must be programmed. The PRESET amount is the value at which the batch will stop and can be programmed up to the value assigned in the MAXIMUM menu. An on and off delay may be set for batching relays.

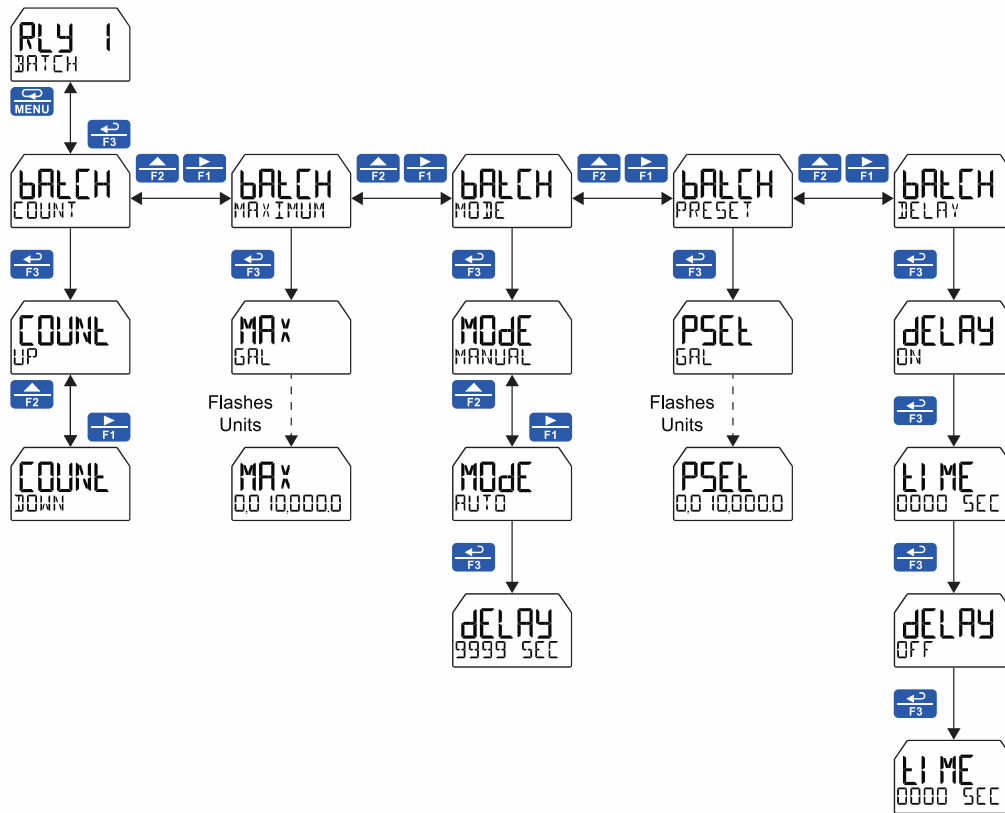

Batch Control Relay 2

The **BATCH** option only appears under relay 2 if relay 1 has also been set to batch control. The second relay may be programmed as a preclose relay or as another batching relay with its own preset amount.

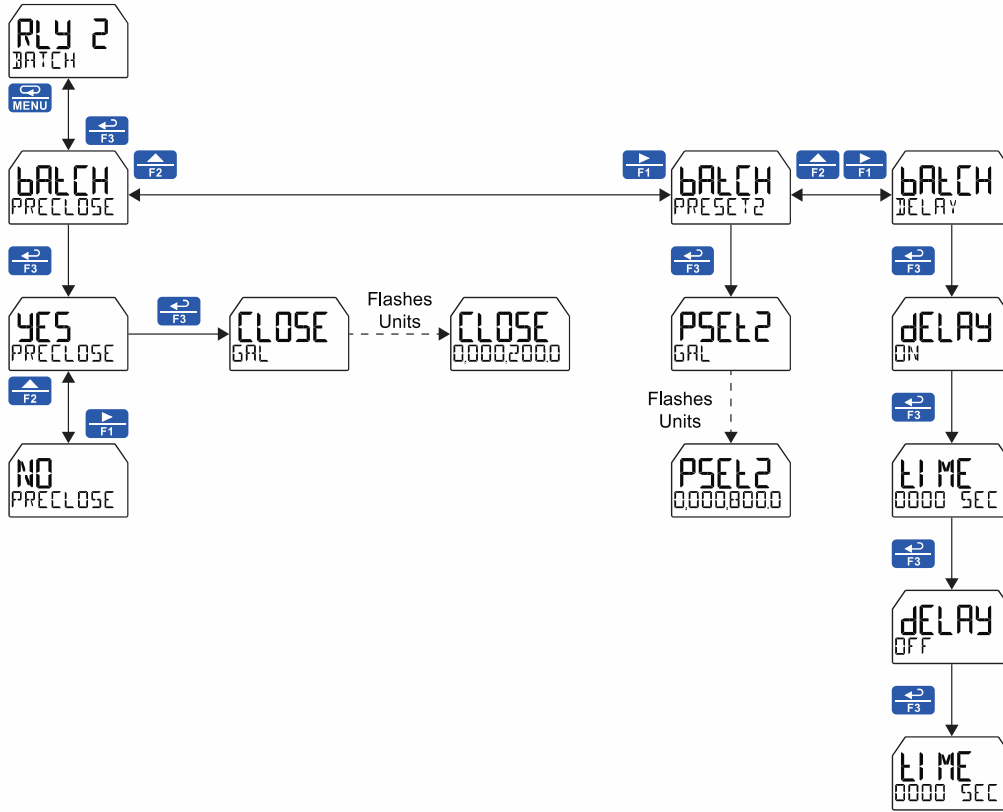

Stopwatch (STPWATCH)

The stopwatch function may be used to manually run and control a process for a specific time interval up to 99 hrs., 59 min, and 59 seconds. The stopwatch function may be assigned to any relay. There are three settings needed to use the function effectively.

1. Assign stopwatch to either top or bottom display
2. Assign the relay to control the process (on/off)
3. Assign a function key or digital input to start/stop the stopwatch

Application Example

To maintain consistency of a product, it is necessary to take and test samples at different times throughout the day. The stopwatch function is used to open and close a solenoid valve to know the exact amount of time needed to complete the desired sample. Once this is determined, the timer function can be used to automatically take a sample (batch) based on the time determined using the stopwatch function.

Setup: Assign the following to *Stopwatch Function*

- Bottom display
(see pages 52 & 54 for details how to change the display)
- Relay 1
(see pages 55 & 61 how to change Open Collector and Solid-State Relay functionality)
- F3: Start/Stop
(see pages 77 & 81 for details on how to change the function keys)

Procedure

- Press F3 to start the stopwatch; relay 1 turns on and the process starts running.
- Press F3 to stop the stopwatch; relay 1 turns off and the process stops.
- The bottom display indicates the time it took to complete the sample.

Runtime & Cycle Count (INFO)

The relay information menu shows runtime and cycle count for each relay. These values may be cleared at any time by selecting the *Clear* option (CLEAR?).

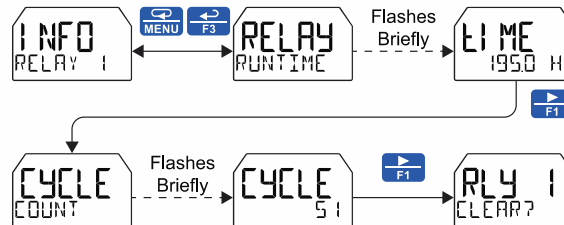

Isolated 4-20 mA Output (4-20 mA)

The 4-20 mA menu is used to scale the isolated 4-20 mA output based on display values. This menu is not present on models without a 4-20 mA output option.

The 4-20 mA analog output (if equipped) can be scaled to provide a 4-20 mA signal for the rate or total display range. The output may be disabled (DISABLE) and will only output the minimum signal.

Overrange and underrange values determine what mA signal the meter will output if the input is below the 4 mA output scaled point or the display is above the 20 mA output scaled point. This value may be set to 1 mA, 3.5 mA, 3.8 mA, 20.5 mA, 20.8 mA, 23 mA, or disabled.

No equipment is needed to scale the analog output; simply program two display values and corresponding mA output signals.

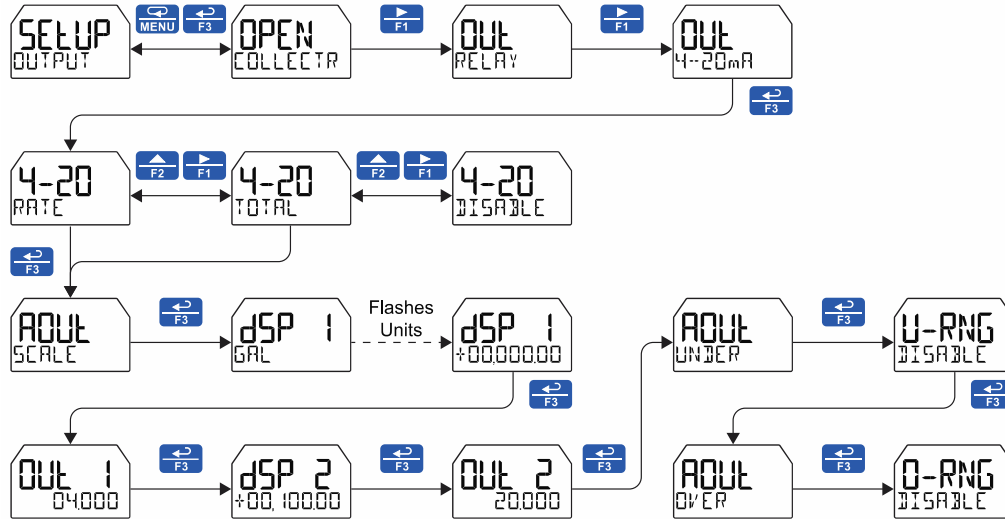

Rate or Total (RATE or TOTAL)

To scale the analog output, enter display value 1 and a corresponding analog output value for this display, then enter display value 2 and a corresponding analog output value for this display value. This will provide a linearly scaled analog output.

Output Manual Control (CONTROL)

The Control menu is used to control the open collector outputs, 4-20 mA analog output, and the relays manually, ignoring the input. Each open collector, relay, and analog output can be programmed independently for manual control. Selecting automatic control sets all relays and analog output for automatic operation.

After selecting manual control for a specific output, you can set the output value. To change the output value, return to the Control menu, select the output to control, select manual control, and enter a new value.

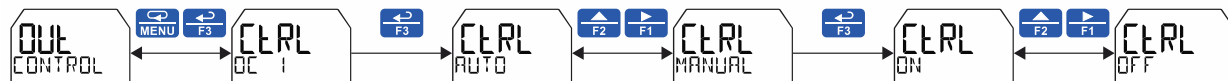

Advanced Features Menu (ADVANCE)

To simplify the setup process, functions not needed for most applications are located in the *Advanced Features* menu. The options under advanced features include *advanced rate, total, and grand total setup, cutoff, gate, filter, password, data log, communications, user function key programming, and system settings.*

Refer to *Display Functions & Messages* on page 43 for complete list of the advanced features menu.

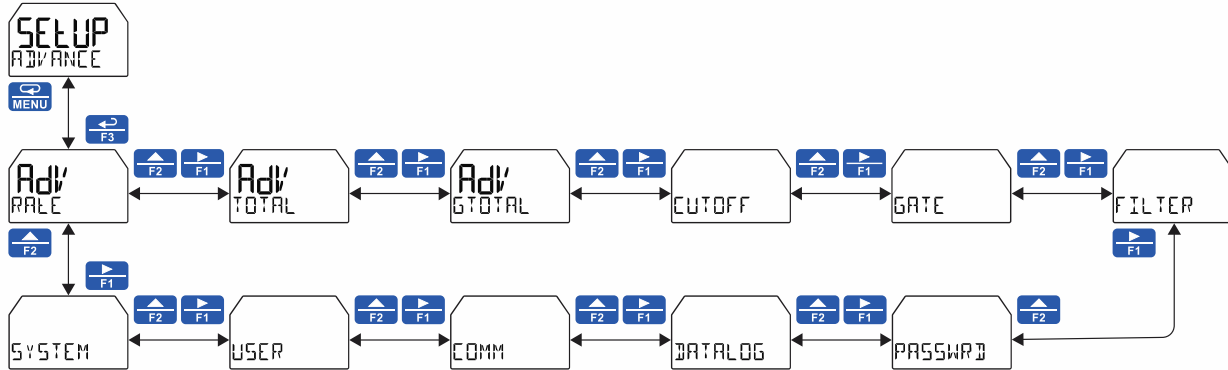

Advanced Rate Setup (ADV RATE)

The *Advanced Rate* menu contains options to apply input signal calibration using a K-Factor or multi-point scale.

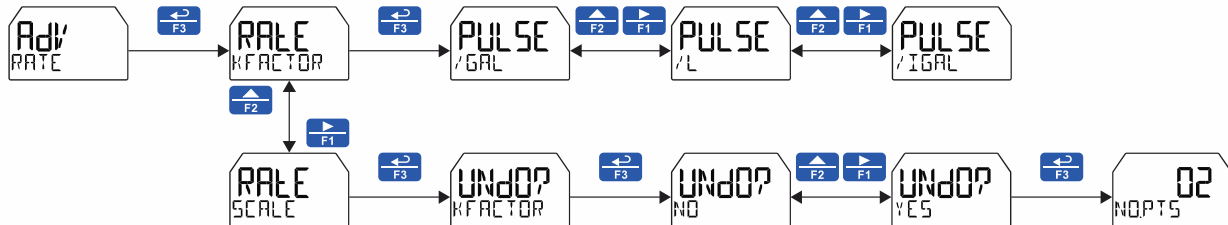

Using MeterView XL

MeterView XL makes programming quick and easy; select the input type, scale the input using the multi-point linearization or enter the k-factor value corresponding to the connected flowmeter. The multi-point scaling can be exported in .csv file format, the saved files can be imported into other meters.

The complete configuration can be read from a connected meter, saved, loaded, or printed.

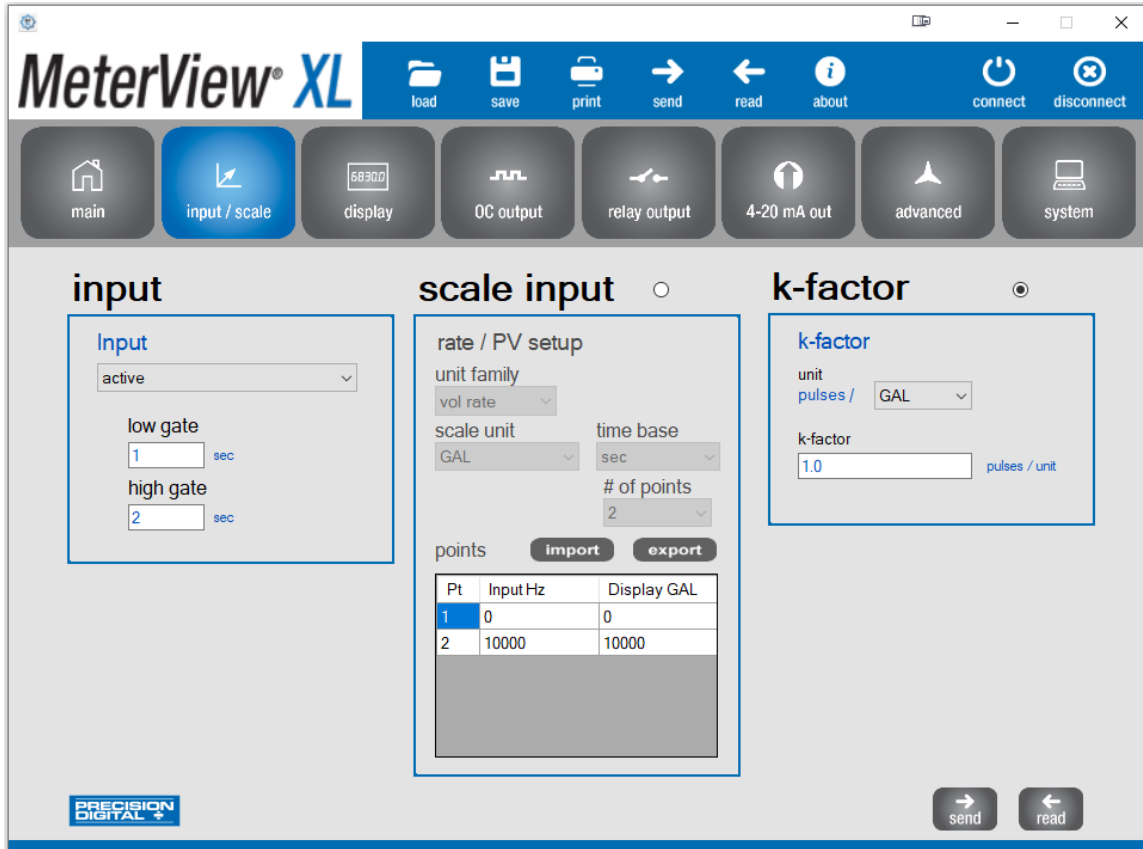

Multi-Point Linearization (LINEAR)

Up to 32 linearization points can be selected for rate under the SCALE function. Multi-point linearization can be used to linearize the input and improve the accuracy of a flowmeter. The easiest way to enter multi-point linearization values is using the MeterView XL software. The input frequency and rate values can also be entered using the CapTouch buttons.

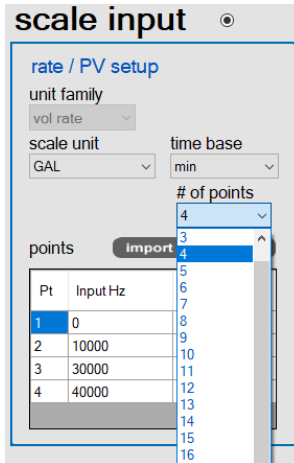

MeterView XL showing the multi-point linearization feature. Up to 32 points can be selected.

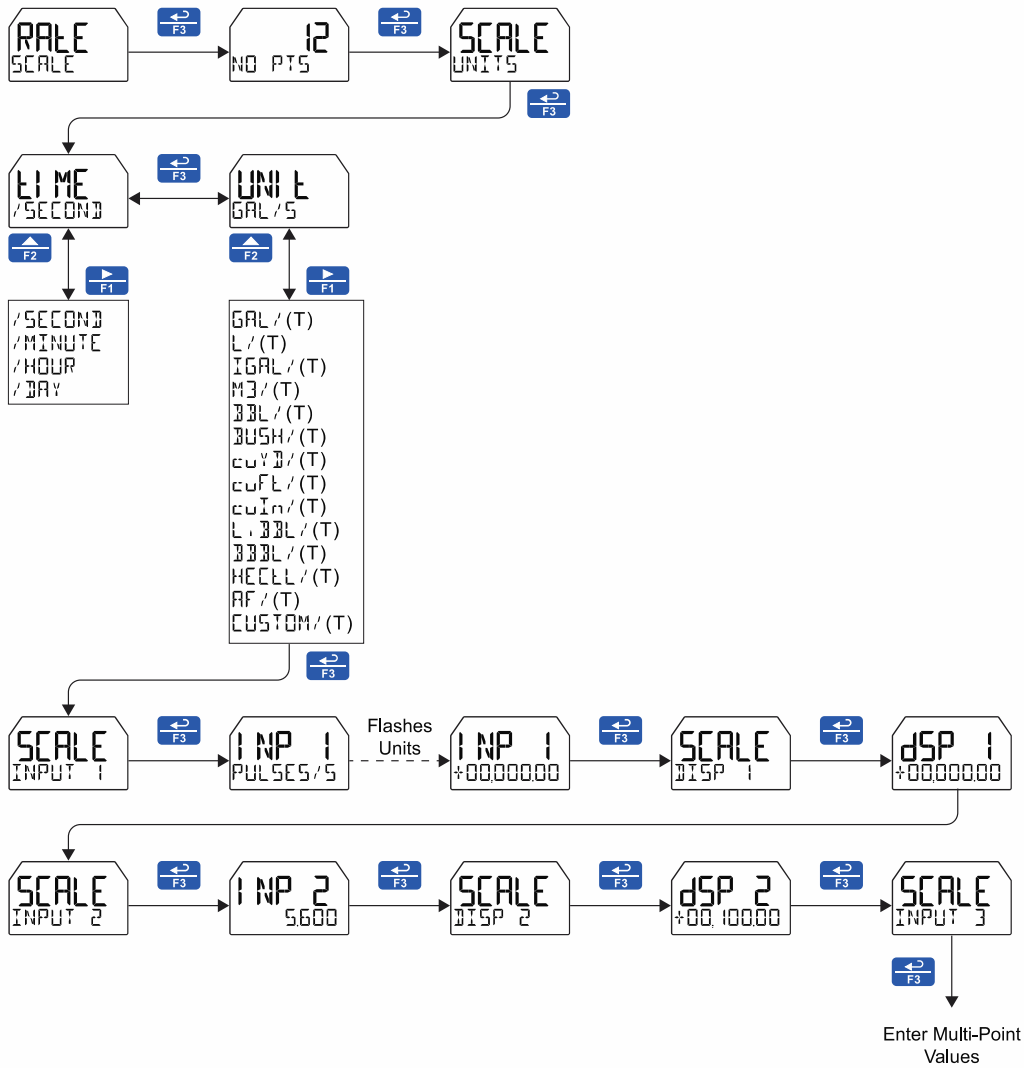

Advanced Total and Grand Total Setup (ADV TOTAL & ADV GTOTAL)

The advanced total and grand total menu contain the count (COUNT) and reset (RESET) menus. The count menu allows the digit limit to be selected between 8-digit (bottom display only) and 13-digit (uses top and bottom display to display full number) and the initial value at which the total or grand total should start counting.

When using a 13-digit total or grand total, press the function key assigned to display (default: F1) to view the full amount once the value has exceeded 100,000,000 (decimal places are automatically truncated). If a 13-digit total or grand total is displayed on the bottom display and the value has exceeded eight digits, the truncated value will flash to indicate that it is not the complete value. To display 13-digit grand total, assigned the top and bottom display to grand total.

The reset menu is used to enable or disable the reset of the total and grand total.

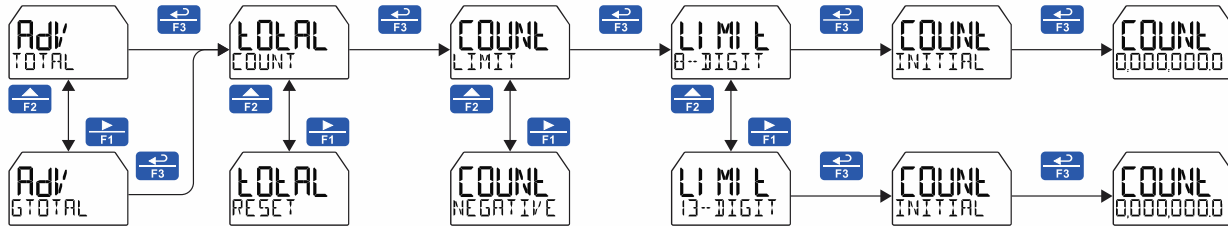

Reset Total & Grand Total

The total and the grand total can be reset manually, using a function key, the digital input, or a Modbus command. The totals can also be reset automatically at specified days and time; up to four day and time can be set up. The totals are saved to non-volatile memory prior to executing the reset command. The previous total and grand total are available for viewing using the function key assigned to *Display* (F1: Default). The previous totals are also available via the Modbus registers.

Time of Day Total Reset

The total and grand total can be set up to reset at a time of day every day or any day of the week. The previous total and grand total are saved prior to applying the reset command.

There are four reset times that can be set up, all choices allow specifying the reset time.

- DAY: Resets every day at the specified time
- SUN - SAT: Resets on the selected day at the specified time
- M-F: Resets Monday through Friday at the specified time

▲ IMPORTANT

- To select the day press the Up key, to select the time press the Right key
- Manual reset can be enabled regardless of the reset time of day setting

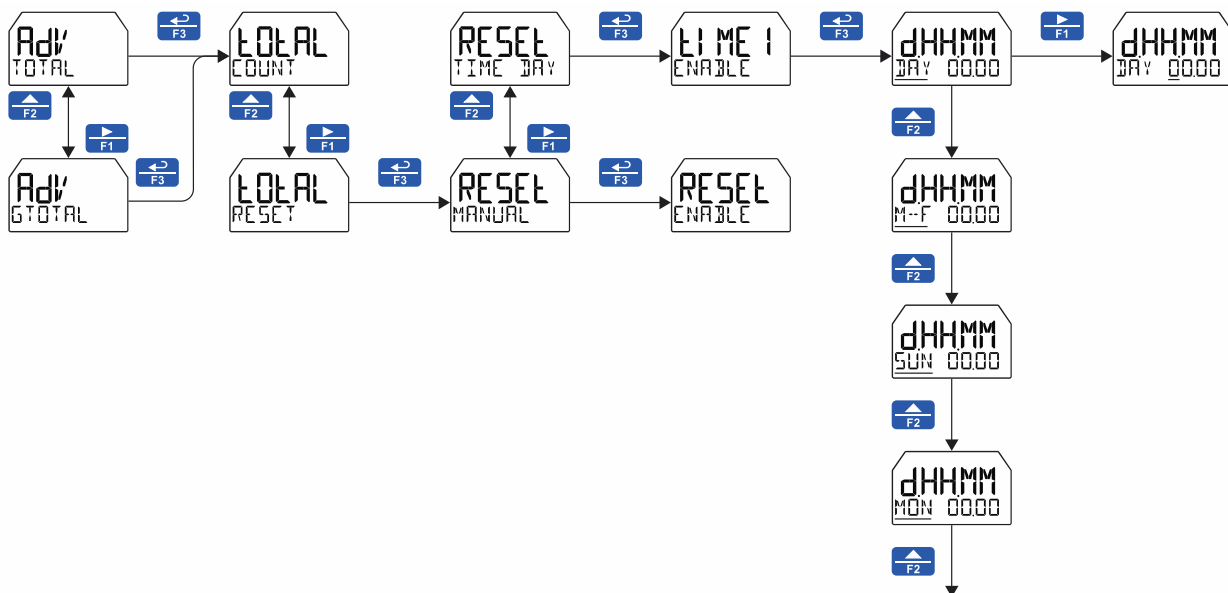

Non-Resettable Grand Total

The grand total reset may be permanently disabled by selecting YES at the PERMLDC menu after disabling grand total reset.

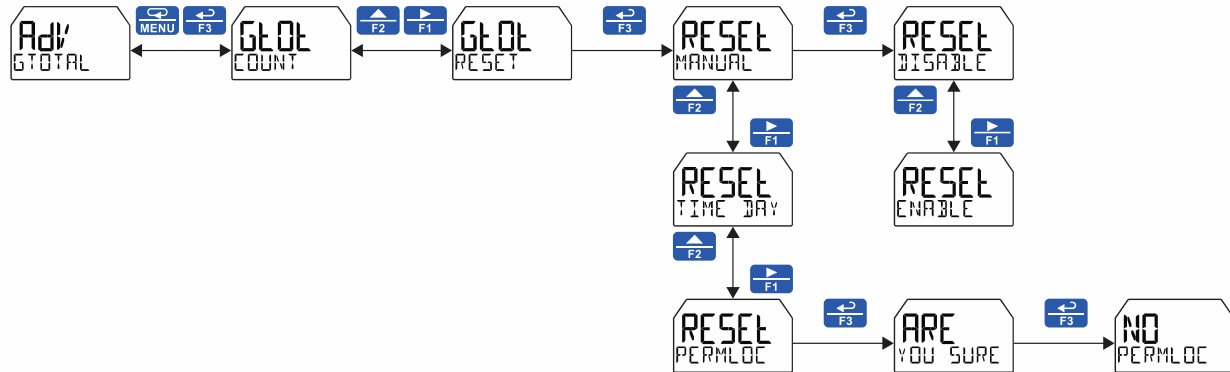

CAUTION

- Use caution when selecting the PERMLDC feature as once the grand total reset has been permanently locked, it cannot be unlocked.

Low-Flow Cutoff (CUTOFF)

The low-flow cutoff feature allows the meter to be programmed so that the output at low flow rates always displays zero on the meter. The cutoff value may be programmed from 0.0 to 99999. The meter will display zero below the cutoff value. The cutoff can be disabled to display negative values.

Gate Function (GATE)

The gate function is used for displaying slow pulse rates. Using the programmable gate, the meter can display pulse rates as slow as 1 pulse every 9,999 seconds (0.0001 Hz). The gate function can also be used to obtain a steady display reading with a fluctuating input signal.

There are two settings for the Gate, low gate (LOW GATE) and high gate (HI GATE).

Low Gate (LOW GATE)

For most applications, low gate setting should be left at 1 second. Increase low gate setting to obtain a steadier rate display. The rate display will update in accordance with the low gate setting, for example if low gate is set at 10, the display will update every 10 seconds; changes in rate between updates will not be reflected until next display update. The total is updated faster and independent of the low gate setting.

High Gate (HI GATE)

Set the high gate value to correspond to the highest expected pulse period (lowest pulse rate). For instance if the meter must display a rate when there is 1 pulse coming into the meter every 10 seconds, set the high gate to 11 seconds. When the signal is removed from the meter, the display will show the last reading for 11 seconds; then it will read zero. The maximum high gate value is 9,999 seconds, which allows the display of a 0.0001 Hz frequency.

Contact Debounce Filter (FILTER)

The filter function (FILTER) can be used for applications where the meter is set up to count pulses generated by switch contacts. These are the settings and their maximum frequencies:

- Disable: Greater than 100 kHz (no filter)
- Fast: 1,000 Hz
- Medium: 240 Hz
- Slow: 100 Hz

The medium filter ignores signals faster than 240 Hz max, or pulse widths less than 2 ms at 50% duty cycle. The slow filter ignores signals higher than 100 Hz, or pulse widths less than 5 ms at 50% duty cycle.

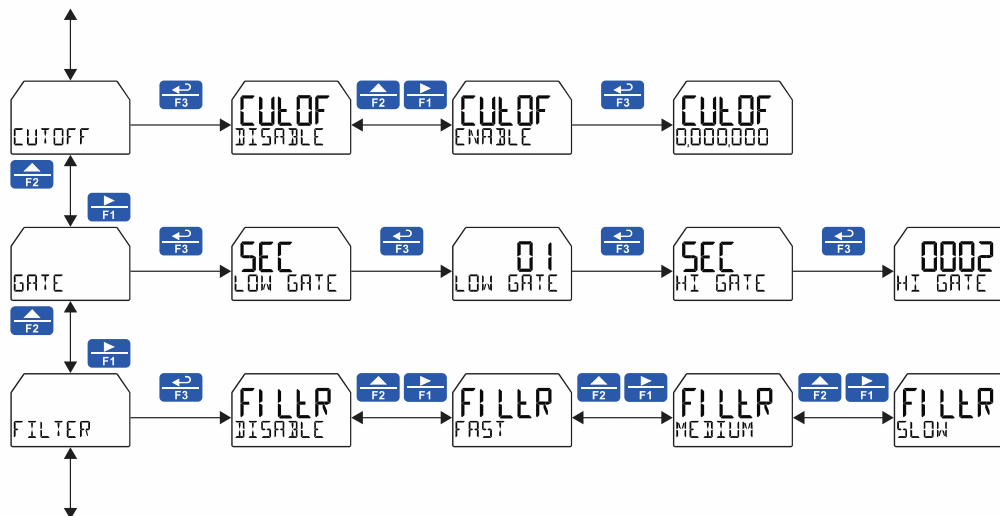

Bi-Directional Flow

The meter can be set up to process bi-directional flow by doing the following:

1. Connect the bi-directional switch from the flowmeter to the digital input terminals of the PD6938
2. Set up the digital input (DI) to activate the flow function: *Reversed* or *Forward*
 The flow direction function is activated when the switch is closed (Logic: Low)
Reverse = Negative rate is displayed, total decreases
Forward = Positive rate is displayed, total increases
3. Disable the low-flow cutoff feature
4. Enable negative count in the *Advanced Total* and *Grand Total* menus, if total is expected to go negative

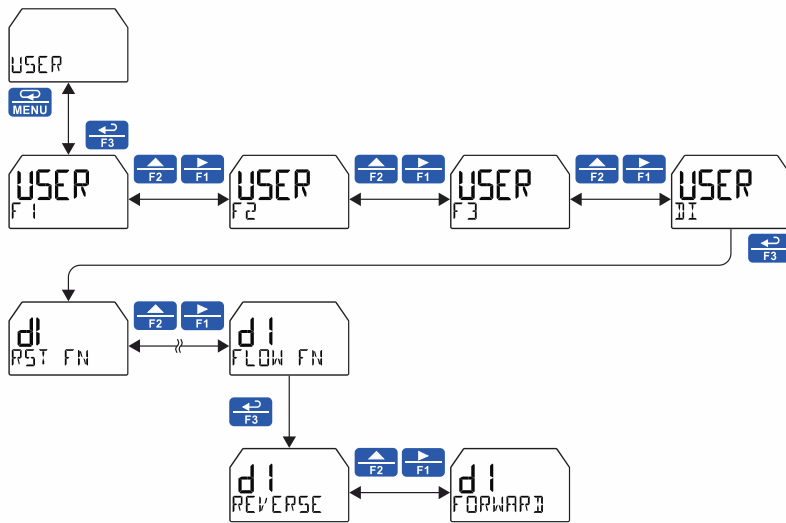
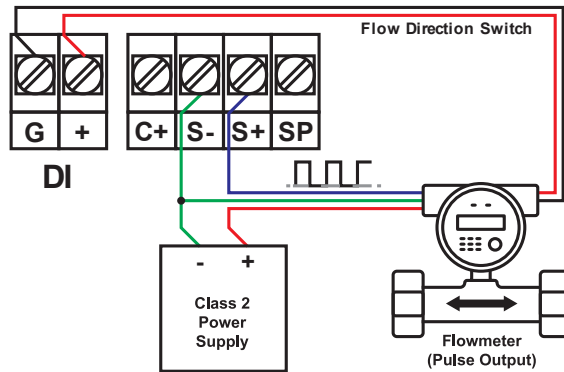

Enabling Password Protection (PASSWRD)

The *Password* menu is used for programming security to prevent unauthorized changes to the programmed parameter settings or undesired resetting of the total or grand total. There are three separate passwords available that can be set independently of each other: *Main*, *Total*, and *Grand Total*. The *Main*, *Total*, and *Grand Total* passwords prevent access to the meter *Programming Mode*. *Total* and *Grand Total* passwords prevent resetting of the total and grand total, respectively.

To set a password, enter the *Password* menu and program a five-digit password. When a password has been enabled, the lock icon  will display in the upper-left side of the display. For instructions on how to program numeric values see *Setting Numeric Values* on page 48.

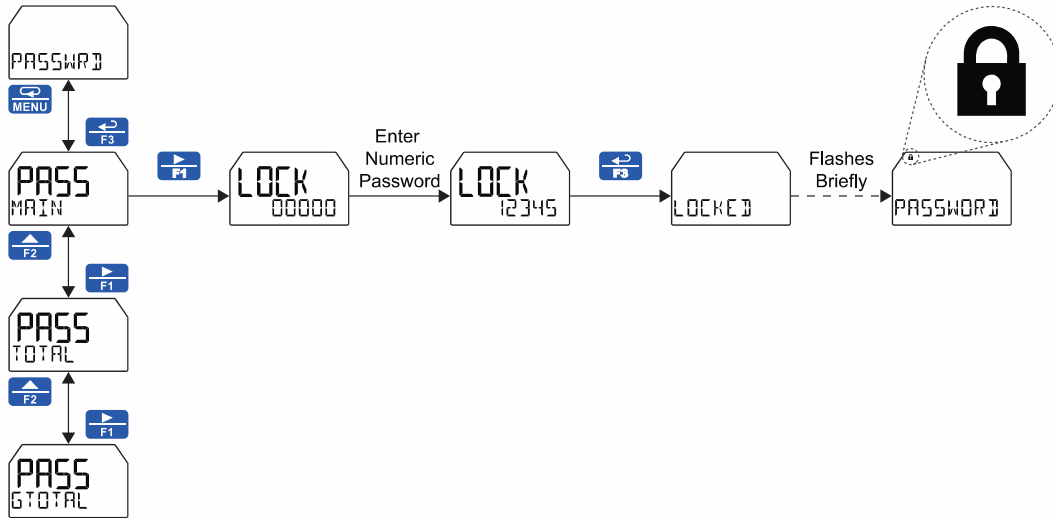

Making Changes to a Password Protected Meter

If the *Main* password is enabled, the meter will display the message `LOCKED` when the *Menu* button is pressed. If the *Total* or *Grand Total* passwords are enabled, the meter will display the message `LOCKED` when trying to reset or change the total or grand total. Press the *Enter* button while the message is being displayed and enter the correct password to gain access to the menu. After exiting *Programming Mode*, the meter returns to its password protected condition.

Disabling Password Protection

To disable the *Main*, *Total*, or *Grand Total* passwords, access the *Password* menu and clear the desired password either by pressing and holding the *Right Arrow* button until all digits reset to zero or manually changing all of the digits to zero. When the **Enter** button is pressed, the meter will display `UNLOCKED` and will no longer require a password to access *Programming Mode*, or a password to reset or change the total or grand total, depending on which password was cleared.

Note: If the meter is password protected and the password has been forgotten, the password may be overridden using the master password: **50865**

Data Log Menu (DATALOG)

The *Data Log* menu is used to set up, view, and erase the data log. The user can choose what information to log, when, and how to log it. The PD6938 is capable of data logging up to 2,032 records. The log file can be downloaded using the MeterView XL software and it can be saved in .csv file format.

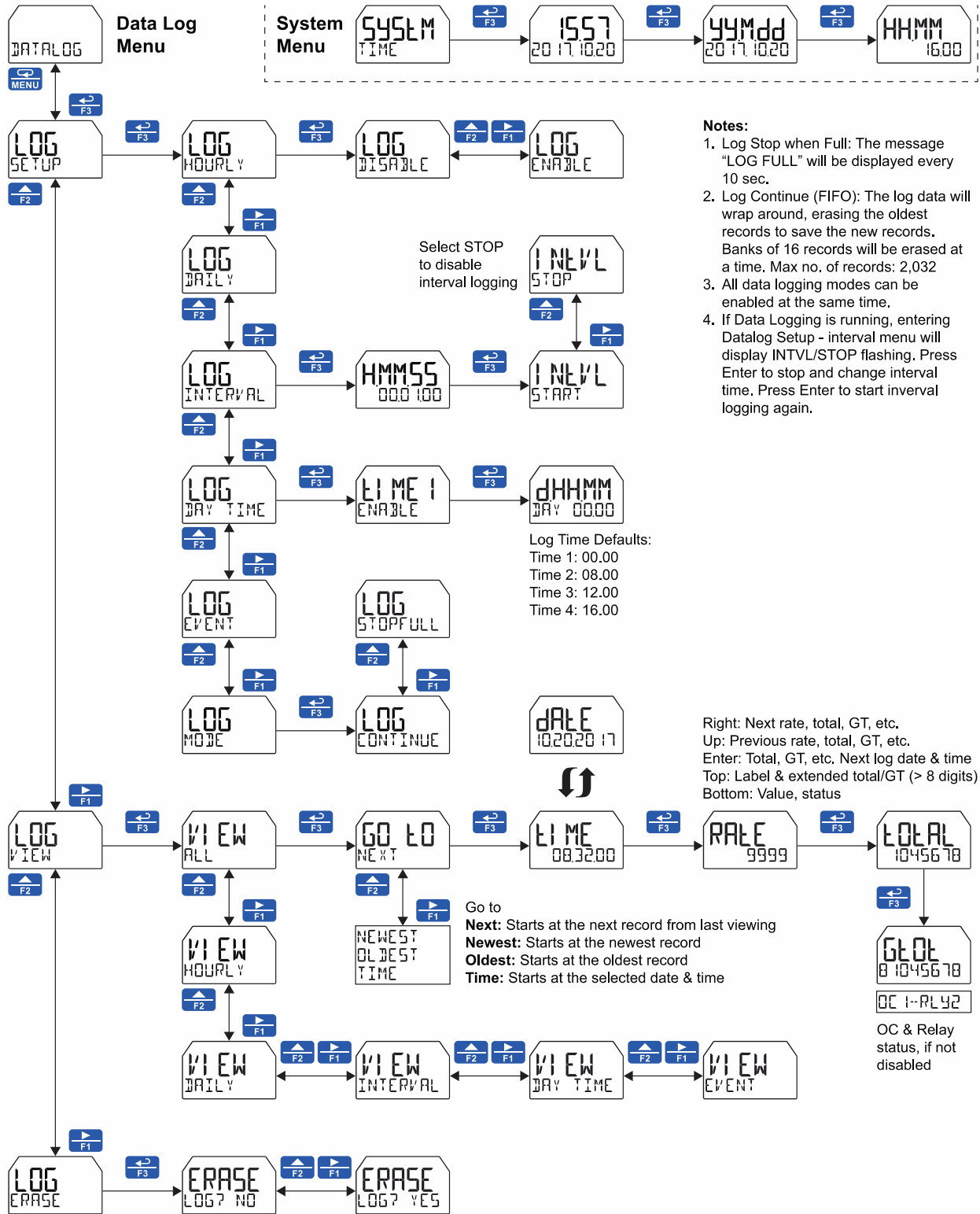

Data Log Setup with MeterView XL

The easiest way to set up the data logger is using the MeterView XL software connected via the micro-USB port or the RS-485 Modbus connection. There are many ways to log data using the on-board memory. Use the MeterView XL software to download the data or a Modbus application.

- Log time: Every day or any day of the week
- Log time interval: Select the logging interval
- Select to log continuously or stop when full

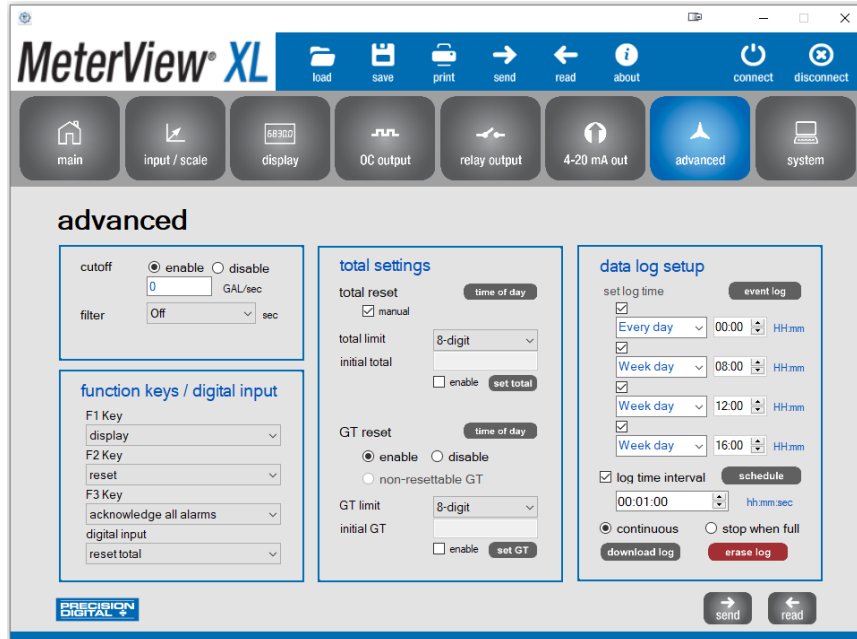

There are many events upon which a log can be taken.

- Total and grand total reset
- Hold/Unhold outputs
- Open collector trigger
- Relay trigger

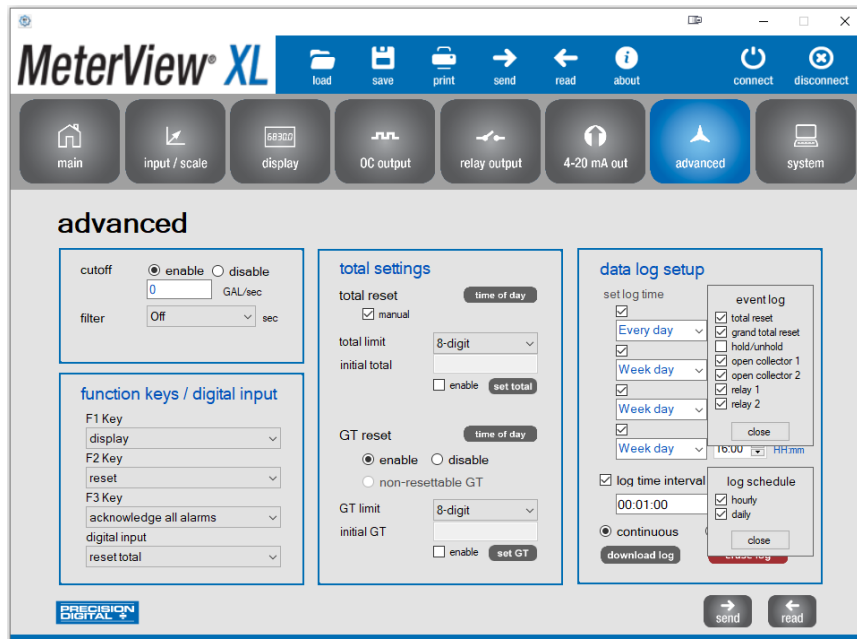

Data Log Example

The log file is saved in .csv file format and it contains all the information selected in the data log setup.

- Information header
- Date & time
- Log sequence
- Log source
- Rate, total, and grand total with units
- Alarm state
- Open collector and relay state

A	B	C	D	E	F	G	H	I	J	K	L	M	N
1	Meter Model	PD6938	Firmware	1	MeterView 2.1.0	Download Time	April 18 2023 10:59 AM						
2	Date	Time	Sequence Source	Rate	Rate Units	Total	Total Unit	Grand Total	Grand Total Units	OC1	OC2	Relay1	Relay2
3													
4	Apr/18/2023	10:17:57	1 OC1	100	GAL/sec	6053	GAL	6053	GAL	Alarm On	Alarm On	On	Off
5	Apr/18/2023	10:17:57	1 OC2	100	GAL/sec	6053	GAL	6053	GAL	Alarm On	Alarm On	On	Off
6	Apr/18/2023	10:17:57	1 Rly1	100	GAL/sec	6053	GAL	6053	GAL	Alarm On	Alarm On	On	Off
7	Apr/18/2023	10:18:00	2 Interval	100	GAL/sec	6353	GAL	6353	GAL	Alarm On	Alarm On	On	Off
8	Apr/18/2023	10:18:07	3 Rly1	64	GAL/sec	6975	GAL	6975	GAL	Alarm On	Alarm On	Off	Off
9	Apr/18/2023	10:18:09	4 OC2	26	GAL/sec	7028	GAL	7028	GAL	Alarm On	OC2 Off	Off	Off
10	Apr/18/2023	10:18:12	5 OC1	10	GAL/sec	7067	GAL	7067	GAL	OC1 Off	OC2 Off	Off	Off
11	Apr/18/2023	10:18:35	6 OC1	36	GAL/sec	7347	GAL	7347	GAL	Alarm On	OC2 Off	Off	Off
12	Apr/18/2023	10:18:36	7 OC2	45	GAL/sec	7398	GAL	7398	GAL	Alarm On	Alarm On	Off	Off
13	Apr/18/2023	10:18:47	8 Rly1	60	GAL/sec	8022	GAL	8022	GAL	Alarm On	Alarm On	On	On
14	Apr/18/2023	10:18:47	8 Rly2	60	GAL/sec	8022	GAL	8022	GAL	Alarm On	Alarm On	On	On
15	Apr/18/2023	10:18:57	9 Rly1	60	GAL/sec	8622	GAL	8622	GAL	Alarm On	Alarm On	Off	Off
16	Apr/18/2023	10:18:57	9 Rly2	60	GAL/sec	8622	GAL	8622	GAL	Alarm On	Alarm On	Off	Off
17	Apr/18/2023	10:19:00	10 Interval	60	GAL/sec	8802	GAL	8802	GAL	Alarm On	Alarm On	Off	Off
18	Apr/18/2023	10:19:21	11 Rly1	60	GAL/sec	10062	GAL	10062	GAL	Alarm On	Alarm On	On	Off
19	Apr/18/2023	10:19:31	12 Rly1	60	GAL/sec	10662	GAL	10662	GAL	Alarm On	Alarm On	Off	Off
20	Apr/18/2023	10:19:54	13 Rly1	60	GAL/sec	12041	GAL	12041	GAL	Alarm On	Alarm On	On	On
21	Apr/18/2023	10:19:54	13 Rly2	60	GAL/sec	12041	GAL	12041	GAL	Alarm On	Alarm On	On	On
22	Apr/18/2023	10:20:00	14 Interval	60	GAL/sec	12401	GAL	12401	GAL	Alarm On	Alarm On	On	On
23	Apr/18/2023	10:20:04	15 Rly1	60	GAL/sec	12641	GAL	12641	GAL	Alarm On	Alarm On	Off	Off
24	Apr/18/2023	10:20:04	15 Rly2	60	GAL/sec	12641	GAL	12641	GAL	Alarm On	Alarm On	Off	Off
25	Apr/18/2023	10:20:27	16 Rly1	60	GAL/sec	14021	GAL	14021	GAL	Alarm On	Alarm On	On	Off
26	Apr/18/2023	10:20:37	17 Rly1	60	GAL/sec	14621	GAL	14621	GAL	Alarm On	Alarm On	Off	Off
27	Apr/18/2023	10:21:00	18 Interval	60	GAL/sec	16001	GAL	16001	GAL	Alarm On	Alarm On	On	On
28	Apr/18/2023	10:21:01	19 Rly1	60	GAL/sec	16061	GAL	16061	GAL	Alarm On	Alarm On	On	On
29	Apr/18/2023	10:21:01	19 Rly2	60	GAL/sec	16061	GAL	16061	GAL	Alarm On	Alarm On	On	On
30	Apr/18/2023	10:21:11	20 Rly1	60	GAL/sec	16661	GAL	16661	GAL	Alarm On	Alarm On	Off	Off
31	Apr/18/2023	10:21:11	20 Rly2	60	GAL/sec	16661	GAL	16661	GAL	Alarm On	Alarm On	Off	Off
32	Apr/18/2023	10:21:34	21 Rly1	60	GAL/sec	18041	GAL	18041	GAL	Alarm On	Alarm On	On	Off
33	Apr/18/2023	10:21:44	22 Rly1	60	GAL/sec	18641	GAL	18641	GAL	Alarm On	Alarm On	Off	Off
34	Apr/18/2023	10:22:00	23 Interval	60	GAL/sec	19601	GAL	19601	GAL	Alarm On	Alarm On	Off	Off
35	Apr/18/2023	10:22:07	24 Rly1	60	GAL/sec	20021	GAL	20021	GAL	Alarm On	Alarm On	On	On
36	Apr/18/2023	10:22:07	24 Rly2	60	GAL/sec	20021	GAL	20021	GAL	Alarm On	Alarm On	On	On
37	Apr/18/2023	10:22:17	25 Rly1	60	GAL/sec	20621	GAL	20621	GAL	Alarm On	Alarm On	Off	Off

▲ IMPORTANT

- The function keys and the digital input can be used to log manually at any time.

Serial Communications (COMM)

The Communications menu is used to view and setup serial parameters necessary for communication via Modbus RTU. The PD6938 can be used as a Server-only device on an RS-485 network. The meter address (Server ID) may be programmed between 1 and 247. When using more than one meter in multi-drop mode, each device must have a unique Server ID.

The baud rate and parity selected must match the settings for all other devices on the network. The baud rate may be set to 1,200; 2,400; 4,800; 9,600; 19,200; 38,400; or 57,600 bps.

The transmit delay may be set between 0 and 199 ms.

The parity can be set to even, odd, or none with 1 or 2 stop bits.

A Modbus Tag can be programmed to differentiate between multiple units on the network.

Refer to the ProtEX+ and VantageView+ PD6938 Modbus® Register Tables located at www.predig.com for details.

Programmable Function Keys User Menu (USER)

The User menu allows the user to assign the CapTouch buttons function keys F1, F2, and F3, and the digital input (located on the input signal connector) to access some of the menus or to activate certain functions immediately (e.g. reset max & min, hold relay states, etc.). This allows the meter to be greatly customized for use in specialized applications.

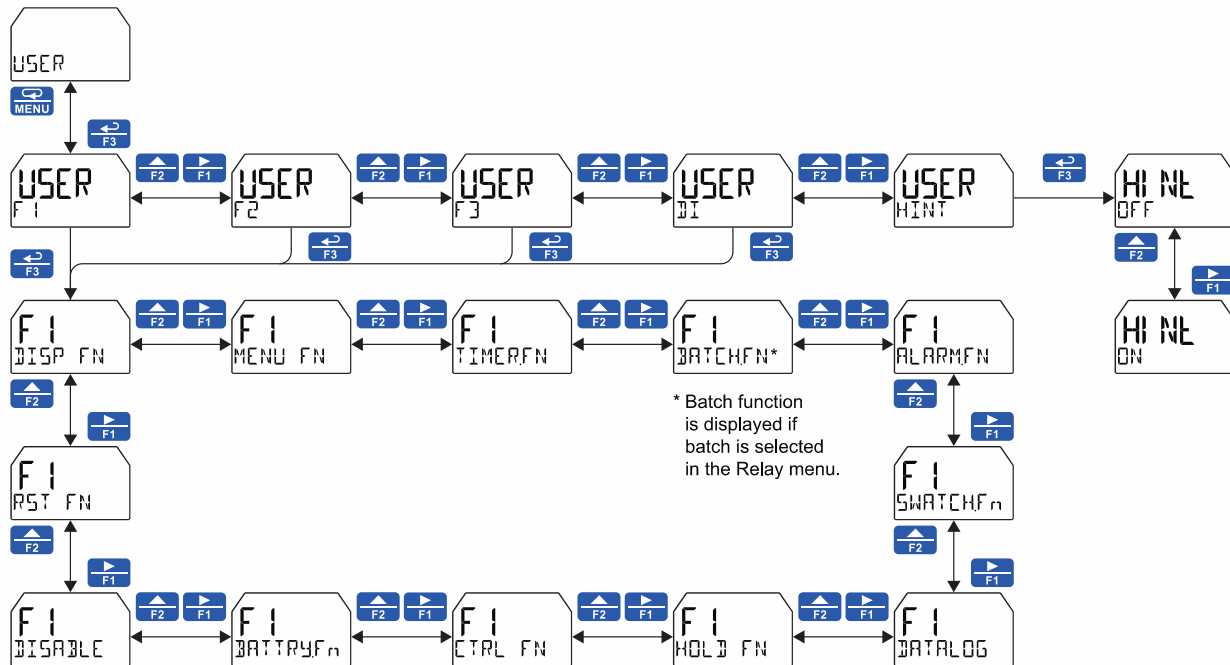

Function Keys & Digital Input Available Settings

Refer to the following table for descriptions of each available function key or digital input setting.

Display	Description
DISP FN	Set the function key or digital input to display a value
DISPLAY	Cycle grand total, previous total, previous grand total, max, min, rate, and total
▯ RATE	Display the rate
▯ TOTAL	Display the total
DISP GT	Display the grand total
PREV TOT	Display the previous total
PREV GT	Display the previous grand total
PCTRATE	Display the rate's percentage based on the bargraph scale
▯ UNITS	Display rate, total, and grand total units
▯ TAG	Display the tags
DISPMIN	Display the minimum rate value
DISPMAX	Display the maximum rate value
MIN MAX	Display the minimum and maximum rate value
▯ FREQ	Display the current input frequency
▯ mAOUT	Display the current mA output value
MENU FN	Set the function key or digital input to access a menu
RLY INFO	Go to relay information menu (INFO)
MANCTRL	Go to output control menu (CONTROL)
TIMR OC1	Open collector 1 timer
TIMR OC2	Open collector 2 timer
TIMER R1	Relay 1 timer
TIMER R2	Relay 2 timer
TIMERFN	Set the function key or digital input to start or stop a timer
STARTALL	Start all timers
STOPALL	Stop all timers
SSTPALL	Start or stop all timers
OC1	Start/stop open collector 1 timer
OC2	Start/stop open collector 2 timer
RLY1	Start/stop relay 1 timer
RLY2	Start/stop relay 2 timer
START	Start the selected timer output
STOP	Stop the selected timer output
STR--STP	Start or stop the selected timer output
BATCHFN	Set the function key or digital input to batch control
START	Start a batch
STOP	Stop a batch

Display	Description
STR--STP	Start or stop a batch
PRESET	Preset batch amount
ALARMFN	Set the function key or digital input to acknowledge an alarm
ACK	Acknowledge all active alarms
SETPOINT	Set all output set point
SETPTOC1	Set open collector 1 set point
SETPTOC2	Set open collector 2 set point
SETPTR1	Set relay 1 set point
SETPTR2	Set relay 2 set point
SWATCHFN	Set the function key or digital input to activate stopwatch
START	Start the stopwatch
STOP	Pause/Stop the stopwatch
STR--STP	Start or stop the stopwatch
DATALOG	Set the function key or digital input to activate data log function
INTERVAL	Set the function key or digital input to activate interval data log
START	Start interval data log
STOP	Stop interval data log
STR_STP	Start/Stop interval data log
MANUAL	Set the function key or digital input to activate manual data log at anytime
ERASE	Set the function key or digital input to erase the data log
VIEW	Set the function key or digital input to activate view the data log
ALL	View all logs
HOURLY	View hourly logs
DAILY	View daily logs
INTERVAL	View interval logs
DAY TIME	View time of day logs
MANUAL	View manual logs
EVENT	View event logs, select: All events, total reset, grand total reset, total & grand total reset, open collectors, relays, power-up, or hold/unhold
SHORTCUT	Set the function key or digital input to go to a data log menu
SETUP	Go to data log setup
ERASE	Go to erase data log
VIEW	Go to view data log
HOLD FN	Set the function key or digital input to hold an output
HOLD OUT	Hold all outputs
HL UNHLD	Hold or un-hold all outputs
OC 1+2	Hold/un-hold open collector outputs
RLY 1+2	Hold/un-hold relay outputs
mAOUT	Hold/un-hold 4-20 mA output
HOLD	Hold selected output

Display	Description
HL UNHLD	Hold or un-hold selected output
CTRL FN	Set the function key or digital input to activate the control function
AUTO	Set the function key or digital input to return all outputs to automatic mode
OC 1-OC2	Set the function key or digital input to control the open collector output: automatic, on, off, toggle on/off, alternate, or momentary
RY 1-RY2	Set the function key or digital input to control the relay output: automatic, on, off, toggle on/off, alternate, or momentary
SHORTCUT	Set the function key or digital input to go to the output control menu
BATTERYFN	Set the function key or digital input to activate the battery function
RS-485	Set the function key or digital input to turn on, or on/off the Modbus RS-485 communications with battery power
DISABLE	Disable the function key or digital input
RST FN	Set the function key or digital input to reset a value
RESET	Reset min, max, or max/min PV value
R MINMAX	Reset max and min PV value

Enabling the Function Key Hint Feature (HINT)

Enabling the function key hint feature will cause a hint message to be displayed when pressing the F1, F2, or F3 function keys. This text gives a brief description of what the button is programmed to do. Pressing that function key a second time will execute that action.

The hint feature does not affect the digital input (DI) which is intended for immediate execution.

Changing System Settings (SYSTEM)

The System menu contains the following menus: *Analog Output Calibration, Restore Factory Defaults, Backlight, Sensor Power, CapTouch Buttons Operation Mode, Battery, Information, and Date & Time.*

Note: The Analog Output Calibration menu is available only if the option is installed.

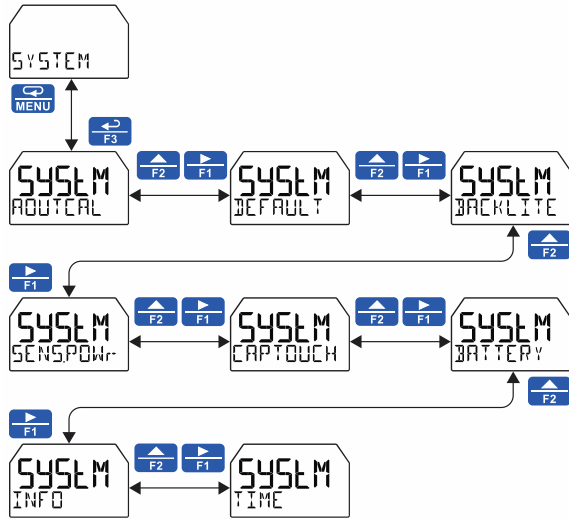

Analog Output Calibration (ADUTCAL)

To perform the analog output calibration, it is recommended to use a milliamp meter with a resolution of at least 0.1 μ A to measure the output current. The values saved internally during this procedure are used for scaling the 4-20 mA output in the *Setup* menu.

4-20 mA Output Calibration Procedure

1. Go to the *Advanced Features* menu and navigate to the **SYSTEM** menu and press Enter. Navigate to **ADUTCAL** and press Enter.
2. The display will show 4 mA. The ProtEX+ mA output should now be close to 4 mA. Enter the actual value read by the digital mA meter on the bottom display and press Enter.
3. The display will show 20 mA. The ProtEX+ mA output should now be close to 20 mA. Enter the actual value read by the digital mA meter on the bottom display and press Enter.
4. The ProtEX+ will now calculate the calibration factors and store them.
5. Press Menu to exit.

Enabling or Disabling the Backlight (BACKLITE)

The backlight may be enabled or disabled using the *System - Backlight* menu. The backlight is enabled by default; if the meter is DC powered, the backlight is constantly on. If the meter is battery powered, the backlight is on according to the setting selected under the *System - Battery - Display* menu.

CapTouch Buttons Operation Mode (CAPTOUCH)

CapTouch buttons have two modes of operation: Normal and Delayed. Delayed mode prevents accidental trigger of the buttons. In the Delayed mode, the buttons enter into a low sensitivity state (sleep) and they ignore quick button presses after 20 seconds of inactivity. To wake up the buttons, press and hold any button for more than 2 seconds, the buttons respond normally.

Battery Operation (BATTERY)

To maximize the battery life of the meter, it is important to set the display, backlight, and RS-485 operation according to what is best for the application. These are the default settings:

- Backlight on: 10 seconds
- LCD Sleep: 10 minutes
- Battery Indicator: Off
- Modbus RS-485: Disabled

Viewing System Information (INFO)

System information, such as software (firmware) number and version, model number, and system tag, may be viewed in the **INFO** menu. Press the *Right Arrow* button to cycle through all available meter information. Press **Menu** to go back to the previous menu.

Meter Operation

The meter is equipped with four CapTouch through-glass buttons. These buttons allow meter operation without removing the cover and exposing the electronics in a hazardous area.

Three CapTouch buttons labeled F1, F2, and F3 can be programmed as function keys to perform a variety of meter functions simply by pressing on the glass over the button. These include resetting the total, resetting the meter's relays or open collectors, starting and stopping timers, displaying max/min values and starting/stopping batches. See *Function Keys & Digital Input Available Settings* on page 81 for a complete list of settings available.

A digital input is available on the meter and it may function in a similar fashion as the function keys to allow remote operation of a single task.





The max & min readings (peak & valley) reached by the process can be displayed either continuously by assigning it to a display line in the *Display* menu, or momentarily by pressing the F1 key (default) or assign it to any of the other function key or the digital input.

Pressing the F1 key cycles through various display values (e.g. Grand total, max, min); press the Enter key to lock the display in the current process value and press the Enter key again to unlock the display.

The relay information menu shows runtime and cycle count for each relay.

Change the display units within the selected unit class at any time without the need to re-scale the meter. Select the desired units via the **UNITS** menu in the **DISPLAY** menu, and the meter automatically converts the display values to the new unit of measure.

CapTouch Buttons Operation



Button	Description (Default Settings)
	Press to enter or exit <i>Programming Mode</i> , view settings, or exit max/min readings.
	Press to display grand total. Continue pressing to cycle through max, min, rate, and total displays.
	Press to access the Reset menu. Press F1 to scroll through the options. Press F3 to reset the currently displayed parameter.
	Press to acknowledge all manually resettable relays or open collectors. Press to lock/unlock the display value after pressing the F1 key.

CapTouch Buttons

The PD6938 is equipped with four capacitive sensors that operate as through-glass buttons so that it can be programmed and operated without removing the cover (and exposing the electronics) in a hazardous area.



These buttons can be turned off for security by selecting the *Off* setting on the switch located on the side of the display module, close to the Menu button.

To actuate a button, press one finger to the window directly over the marked button area. When the cover is removed, the CapTouch buttons can be used after the meter completes a self-calibrating routine (hand symbol  flashes). The sensors are disabled when more than one button is pressed, and they will automatically re-enable after a few seconds (hand symbol  off).

The CapTouch buttons are designed to work under any lighting condition and to protect against false triggering. If the CapTouch buttons are not needed during operation, they can be turned off (slide switch to *Off*).

- To remove cover with power applied (safe area only) or to clean the window, place your hand over the buttons; this will temporarily disable the CapTouch buttons to prevent inadvertent use.
- Keep the window clean.
- Tighten the cover securely.
- Use a password to prevent tampering.

IMPORTANT

- CapTouch buttons will not work if two or more buttons are detected as being pressed simultaneously. Be careful to avoid triggering multiple buttons or reaching across one button location to press another.

Function Keys Operation

During operation, the programmable function keys operate according to the way they have been programmed in the *Advanced Features – User* menu. The table under *CapTouch Buttons Operation* on page 84 shows the factory default settings for F1, F2, and F3.

A hint message may be enabled to provide a description of what each function key does prior to executing their assigned function. See *Enabling the Function Key Hint Feature (HINT)* on page 82.

Digital Input Operation

A digital input is standard on the meter. This digital input is programmed identically to function keys F1, F2, and F3. The input is triggered with a contact closure between DI+ and DI-, or with an active low signal. During operation, the digital input operates according to the way it has been programmed in the *Advanced Features – User* menu. Factory default setting is to reset total.

Maximum/Minimum Readings

The max & min readings (peak & valley) reached by the process can be displayed either continuously or momentarily.

Display momentarily by pressing the F1 function key (default) or assigning to any of the other function keys or to the digital input in the *User* menu.

Display continuously by pressing the **Enter** button while the max/min is being displayed to lock the display. Press **Enter** again to unlock.

Any of the F1-F3 function keys (buttons) and the digital input can be programmed to reset the max & min readings. The meters are set at the factory to display the max reading by pressing the *Right Arrow/F1* button and to use the *Up-Arrow/F2* button to access the *Reset* menu. Press the *Right Arrow* button to cycle through the available parameters to reset.

Top Display: Process Value
Bottom Display: Max & Min

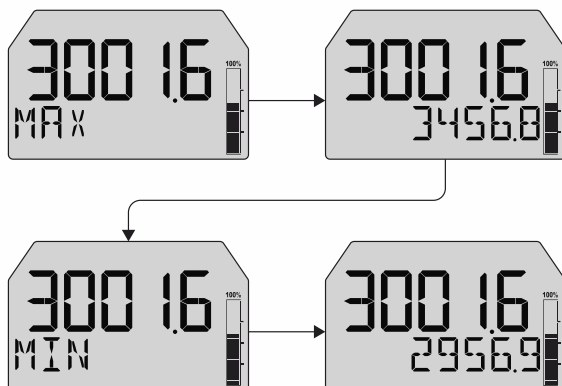

Total Reset Capabilities

The total and grand total can be reset using a CapTouch button, an external contact closure on the digital input, or MeterView XL software. In addition, both total and grand total reset can be password protected to prevent unauthorized resets.

Time of Day Total Reset

The total and grand total can be set up to reset at a time of day every day or any day of the week. The previous total and grand total are saved prior to applying the reset command. The previous totals can be read via the F1 function key and the Modbus registers.

There are four reset times that can be set up, all choices allow specifying the reset day and time.

Total Reset via CapTouch Button

The CapTouch function key F2 is set up to reset the total. If reset grand total is enabled, it is possible for the user to reset either the total or the grand total without removing the cover or the need for external devices.



Total Reset via Digital Input

The PD6938's digital input can also be used to reset the total or grand total.

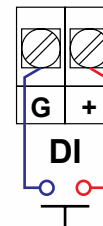

Total Reset Password Protection

Total and grand total passwords can be set to prevent resetting the total or grand total unless a password is entered. Grand total reset can be disabled through the meter interface, and it can also be permanently disabled. See *Bi-Directional Flow* on page 75 for details.

Non-Resettable Grand Total

The user can set up the grand total to be non-resettable by selecting **YES** at the **PERMLOC** menu; see page 73 for details. Once this is done, the grand total can never be reset.

Runtime & Cycle Count (INFO)

The relay information menu shows runtime and cycle count for each relay. These values may be cleared at any time by selecting the *Clear* option (CLEAR?). If the cycle count or runtime values need to be changed on a frequent basis, it would be convenient to set up a CapTouch button or the digital input to simplify this process.

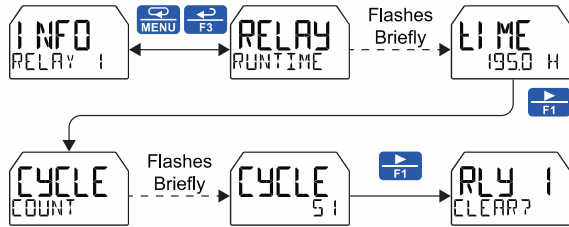

Note: See the menu tree under *Solid-State Relay Outputs (RELAY)* on page 61 for complete menu structure on this feature.

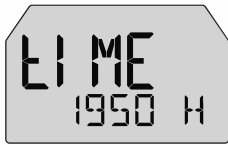

Meter displaying the amount of time a relay has been activated



Meter displaying the number of times a relay has cycled

Changing Engineering Units

During operation of the meter, it is possible to change the display units within the selected unit class without the need to re-scale the meter. The **UNITS** menu in the **DISPLAY** menu allows the unit of measure to be changed (e.g. from gallons/second (GAL/S) to liters/second (L/S)) and the meter will automatically convert the display values to the new unit of measure. If entering a custom unit (CUSTOM), a custom conversion factor will need to be entered. See *Changing the Engineering Units (UNITS)* on page 52.

Batch Controller Operation

Selecting batch control for relay 1 enables the batching features on the meter. The top display is changed to show the total and the bottom display is changed to display the preset batch amount. The function keys are changed so that F1 starts a batch, F2 opens the preset menu to allow the preset value to be changed, and F3 stops the currently running batch. Enabling batch control for relay 1 allows access to the batch menu under relay 2 (this menu does not appear by default). Refer to page 88 for details to setup the batch controller features.

The PD6938 has two open collector outputs that can used for alarm indication. A 4-20 mA output option is also available for retransmitting the process variable.

Default Batch Control Operation

The following describes the operation of the three operating keys as programmed with default settings. The digital input can be used to start and stop the batch using a momentary pushbutton. See examples for *Manual Batch Control* on page 90 and *Automatic Batch Control* on page 91.

START Key (F1)

Press the START button to begin a new batch process. Press the START button to resume a batch that has been stopped.

BATCH Key (F2)

Press the Batch button to access the Preset (batch amount) menu. Program the batch with the arrow keys and confirm with the Enter key.

STOP Key (F3)

Press the STOP key once during a batch to pause. Press the STOP key while paused to stop and cancel the batch.

WARNING

- **Only the STOP Key is Enabled when a Batch is Running.** During a batch process, only the pause/stop functions are operational, other keys are deactivated.

Batch Control Operation Example

The following example shows how two-stage manual batch control functions with a PD6938. This setup will establish a 55-gallon preset for the batch, with a main valve (high flow) that will close at 50 gallons, and a trickle valve (low or restricted flow) that will close at 55 gallons. Because the first batch overruns by 0.10, the batch preset will be changed to 54.90 for the next batch to compensate for overrun.

Two-Stage Manual Batch Control Setup Using Relays 1 & 2

The following table shows the parameters as they appear within the `OUT RELAY` menu.

Parameter	Setting	Function
RELAY OUTPUT 1	RLY 1 BATCH	Press Enter to assign relay 1 batch parameters.
BATCH COUNT	UP or DOWN	Setup batch to count up or down.
BATCH MAXIMUM	1000 GAL	This setting prevents the operator from entering a preset value that exceeds a safety limit for the batch process.
BATCH MODE	MANUAL AUTO	Press Enter to select manual or automatic batch control.
BATCH PRESET	5500 GAL	Enter the batch size.
BATCH DELAY	ON & OFF	Enter the On & Off time delays for relay 1, if desired.
RELAY OUTPUT 2	RLY 2 BATCH	Press Enter to assign relay 2 batch parameters.
BATCH PRECLOSE	YES PRECLOSE 500	Set the pre-close value to 5 to close the valve being controlled by relay 2 so it closes five gallons before reaching the preset.
BATCH DELAY	ON & OFF	Enter the On & Off time delays for relay 2, if desired.
RELAY MESSAGE	MSG RELAY 1	Enter a message to be displayed while relay 1 is on, if desired.
	MSG RELAY 2	Enter a message to be displayed while relay 2 is on, if desired.

If only one-stage batch control is desired, do not assign relay 2 to batch. The following pages show illustrations of how the above settings control the batch operation. The display assignment shown is the default.

Batch Control Relay 1

The batch total can be set to count UP or DOWN.

The batch MAXIMUM is the max preset amount that can be batched.

Batching mode can be set to either manual or automatic operation (MANUAL or AUTO). If setting batching to automatic, a delay before the next batch is started must be programmed.

The PRESET amount is the value at which the batch will stop and can be programmed up to the value assigned in the MAXIMUM menu.

An on and off delay may be set for batching relays.

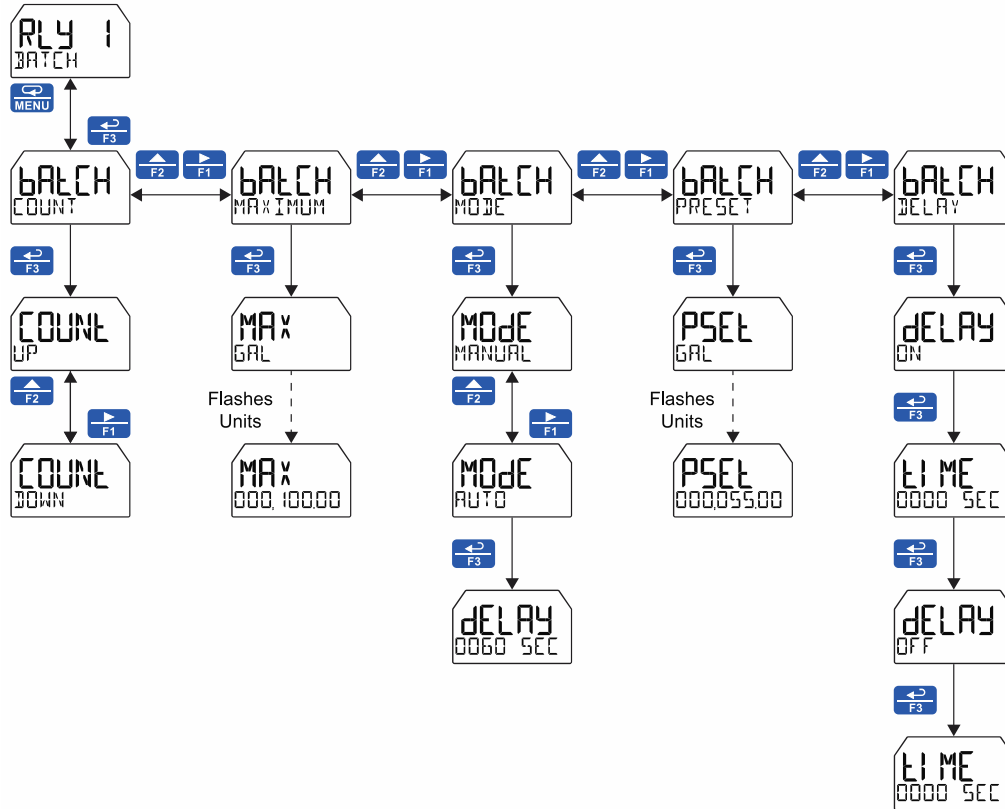

Batch Control Relay 2

The **BATCH** option only appears under relay 2 if relay 1 has also been set to batch control. The second relay may be programmed as a preclose relay or as another batching relay with its own preset amount.

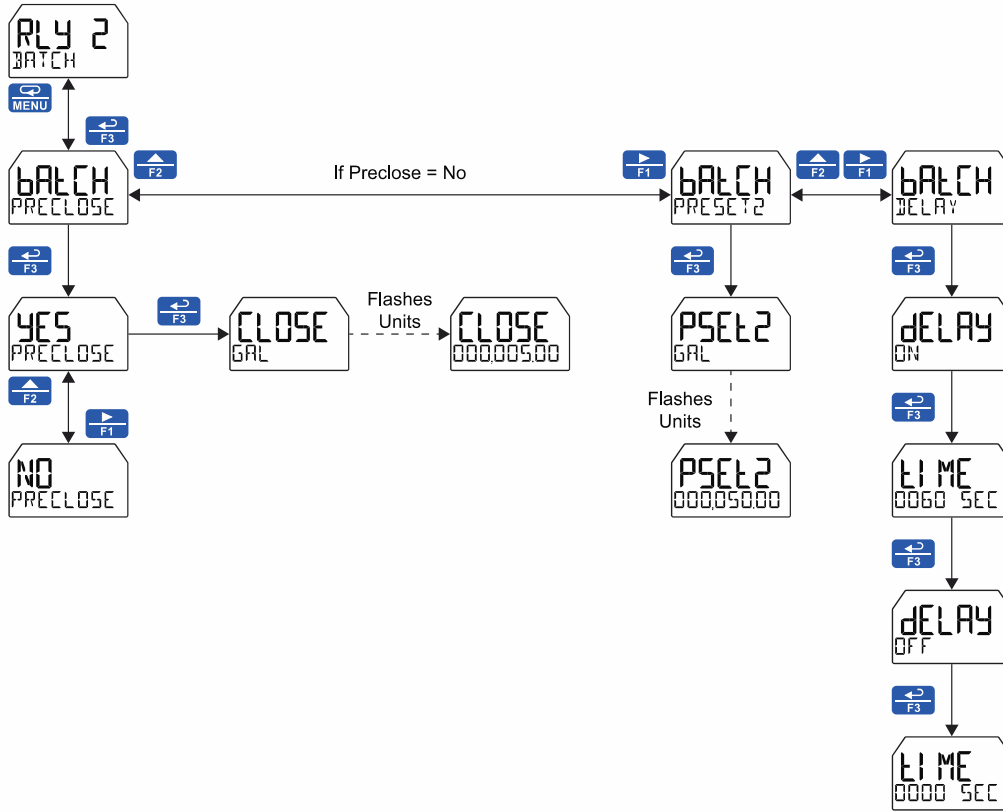

Manual Batch Control

The manual batch control feature is used for batch processes that the operator wants to start manually. It can also be used where the batch size needs to be manually adjusted for each batch. The batch can be controlled by the button on the meter or the digital input.

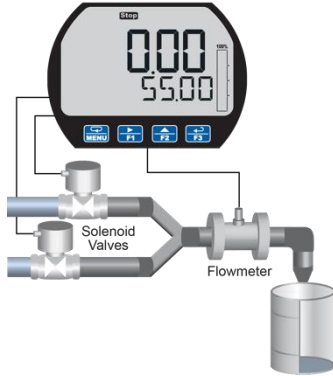

System Setup

Both valves are closed with an empty barrel in place. The batched total is displayed in the upper display, the preset is selected for the lower display.

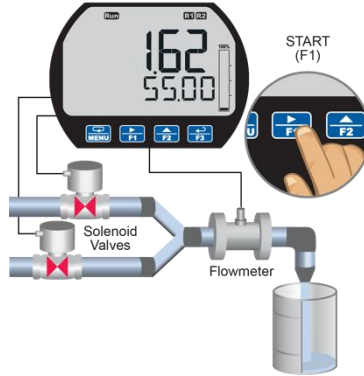

Batch Start

The START button or (F1) is pressed. Both valves open. The barrel begins to fill.

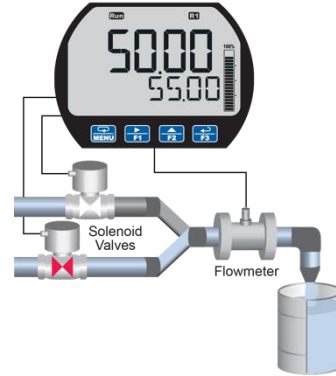

Preclose Valve

When the batch total reaches a value of 50.00 (Preset [55.00] – Pre-close [5.00]) the full-flow valve closes. The fill rate of the tank slows as a result.

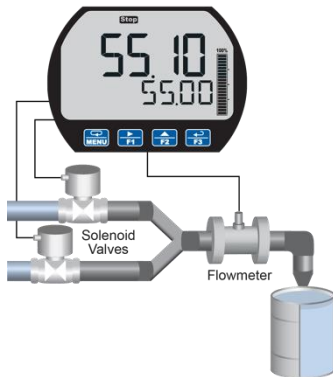

Completed Batch

When the batch is complete, the restricted-flow valve closes. If overrun occurs, then the preset must be adjusted to compensate for the overrun. The next batch will only start after the START button or (F1) is pressed.

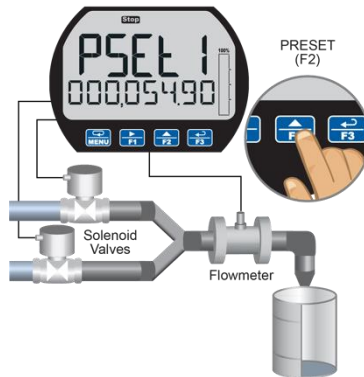

Overrun Correction

To compensate for overrun in the previous batch, adjust the preset to 54.90, so that the next batch is accurate (55.00).

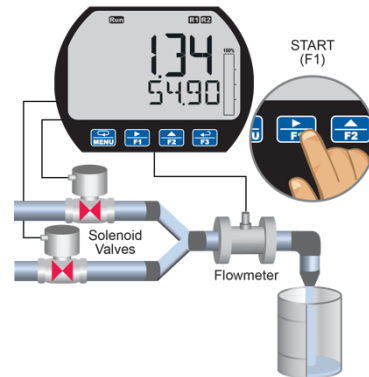

Manual Start of Next Batch

A new, empty, barrel is put in place and the START button or (F1) is pushed to manually start the next batch.



Change Batch Size

While the process is stopped, a new preset fill amount may be selected with the Batch key (F2) for a different size barrel.



Pause/Stop

At any time, press the STOP button or Stop key (F3) once to pause the process, or twice to cancel the batch, which stops the process.



Resume Batch

If the batch has been paused, then press START button or (F1) to resume the batch process.

Automatic Batch Control

The automatic batch control feature is used for batches that start automatically once the previous batch is completed. There is no opportunity for the operator to change the batch size between batches. The batch can be controlled by the button on the meter or the digital.

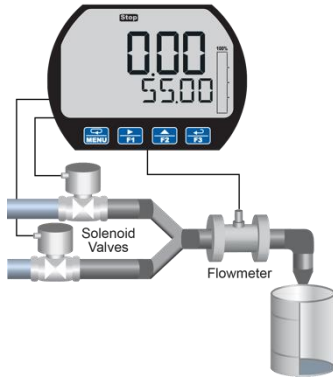

System Setup

Both valves are closed with an empty barrel in place. The batched total is displayed in the upper display, the preset is selected for the lower display.

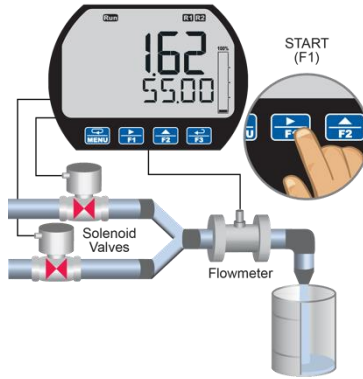

Batch Start

The START button or (F1) is pressed. Both valves open. The barrel begins to fill.

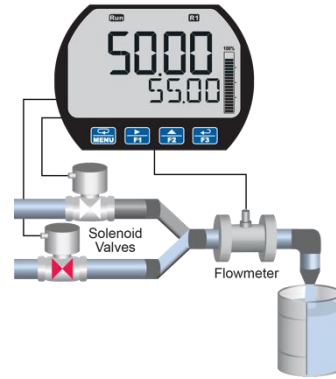

Preclose Valve

When the batch total reaches a value of 50.00 (Preset [55.00] – Pre-close [5.00]) the full-flow valve closes. The fill rate of the tank slows as a result.

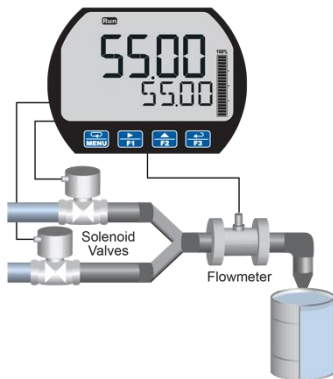

Completed Batch

When the batch is complete, the restricted-flow valve closes. If overrun occurs, then the preset must be adjusted to compensate for the overrun.

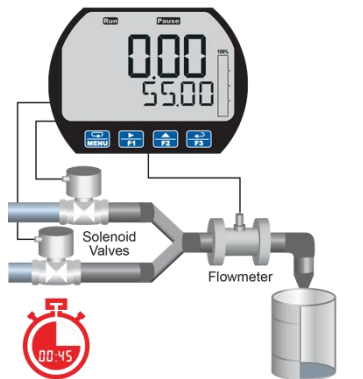

Start Delay

After the batch is completed, the operator removes the full barrel and places an empty barrel; the new batch starts automatically after 60 seconds (Time Delay).

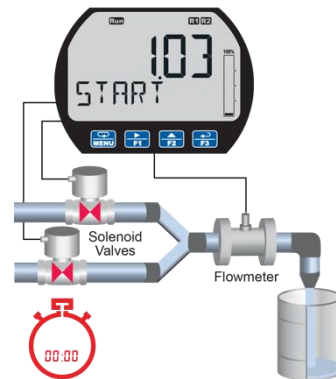

Automatic Start of Next Batch

The new batch begins automatically after 60 seconds, both relays activate and both valves open.



Pause

At any time, press the STOP button or Stop key (F3) once to pause the process.



Resume Batch

If the batch has been paused, then press START button or (F1) to resume the batch process.



Stop Process

At the end of the shift, press STOP button or Stop key (F3) twice to stop the batch process.

Troubleshooting

This product is a highly sophisticated instrument with an extensive list of features and capabilities. If the CapTouch buttons are used to program the meter, it can be a difficult task to keep everything straight. That is why we strongly recommend the use of the free [MeterView XL](#) software for all programming activities. A cable is provided to use the MeterView XL software for programming the meter.

If you have programmed the meter with the CapTouch buttons and it is not working as intended, try re-programming the meter using the MeterView XL software.

Reset Meter to Factory Defaults

When the parameters have been changed in a way that is difficult to determine what's happening, it might be better to start the setup process from the factory defaults. This can be accomplished using MeterView XL software or with the CapTouch buttons.

To load factory defaults:

1. Press the **Menu** button to enter *Programming Mode*.
2. Press the **Right-Arrow** button **twice** and press **Enter** to access the **Advanced** menu.
3. Press the **Up-Arrow** button and press **Enter** to access the **System** menu.
4. Press the **Right-Arrow** button and press **Enter** to access the **Default** menu.
5. Press **Enter** twice in quick succession. The meter will load default settings and restart.

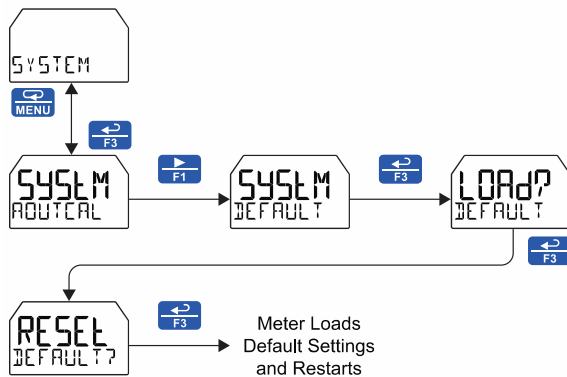

Determining Software Version

To determine the software (firmware) version of a meter:

1. Press the **Menu** button to enter *Programming Mode*.
2. Press the **Up-Arrow** button **twice** and press **Enter** to access the **Advanced** menu.
3. Press the **Up-Arrow** button and press **Enter** to access the **System** menu.
4. Press the **Up-Arrow** button **twice** and press **Enter** to access the **Info** menu.
5. Press the **Right-Arrow** button to cycle through the meter information. When done, press the **Menu** button to return to the previous menu or press & hold **Menu** to exit to Run mode.

Factory Default Settings

The following table shows the factory setting for most of the programmable parameters on the meter.

Parameter	Display	Default Setting
Input Menu		
Input Type	INPUL TYPE	Active
K-Factor	RATE KFACTOR	1.0000
Rate Units	UNITS	Gallons/second
Rate Scale	RATE SCALE	If selected in Advance Rate menu
Input 1	INP 1	0.000 pulses/sec
Display 1	DSP 1	0,000,000
Input 2	INP 2	10,000.00 pulses/sec
Display 2	DSP 2	100.00
Output Menu		
Open Collector Output 1	OUTPUT 1	Disabled
Pulse Factor	FACTOR	1.0
Test Frequency	FREQ	100
Alarm	ALARM	Rate
Alarm Action	ACTION	AUTO
Set Point	SET	20.00
Reset Point	RESET	10.00
Alarm On Delay	DELAY ON	0 seconds
Alarm Off Delay	DELAY OFF	0 seconds
Alarm Failsafe	FAILSAFE	OFF
Red LED	RED	ON
Flash rate	FLASH	ON
Alarm Message	MSG	ON
Message Text	MSG EDIT	ALARM 1
Timer Off Delay	OFFDELAY	1 minute
Timer On Time	ON TIME	1 second
Timer Mode	MODE	Continuous
Open Collector Output 2	OUTPUT 2	Disabled
Set Point	SET	40.00
Reset Point	RESET	30.00
Message Text	MSG EDIT	ALARM 2
Relay Output 1	RELAY 1	Disabled
Alarm	ALARM	Rate
Alarm Action	ACTION	AUTO
Set Point	SET	70.00
Reset Point	RESET	60.00
Alarm On Delay	DELAY ON	0 seconds
Alarm Off Delay	DELAY OFF	0 seconds
Alarm Failsafe	FAILSAFE	OFF
Red LED	RED	ON
Flash rate	FLASH	ON
Alarm Message	MSG	ON
Message Text	MSG EDIT	ALARM 3

Parameter	Display	Default Setting
Sample Count	TOTAL COUNT	1,000 gallons
Sample Time	TOTAL TIME	10 seconds
Batch Count	BATCH COUNT	Up
Batch Max	BATCH MAXIMUM	10,000
Batch Mode	BATCH MODE	Manual
Batch Preset	BATCH PRESET	1,000
Batch On Delay	DELAY ON	0 seconds
Batch Off Delay	DELAY OFF	0 seconds
Timer Off Delay	OFFDELAY	1 minute
Timer On Time	ON TIME	1 second
Timer Mode	MODE	Continuous
Relay Output 2	RELAY 2	Disabled
Set Point	SET	90.00
Reset Point	RESET	80.00
Message Text	MSG EDIT	ALARM 4
4-20 mA Output	4-20 mA	Rate

Advanced Menu		
Signal Conditioning Function	FUNCTION	Linear (2 pts)
Count Limit	COUNT LIMIT	8-Digit Total
Count Initial	COUNT INITIAL	0
Total Reset	TOTAL RESET	Enabled
GTot Reset	GTOT RESET	Disabled
Non-Resettable Grand Total	PERMLOCK	No
Low Cutoff	CUTOFF	Enabled: 0
Filter	FILTER	2.0 seconds
Filter Bypass	BYPAS	0.4 PCT
Main Password	MAIN	00000 (Unlocked)
Total Password	TOTAL	00000 (Unlocked)
GTot Password	GTOTAL	00000 (Unlocked)
Function Key 1	F 1	Display
Function Key 2	F2	Reset
Function Key 3	F3	Acknowledge
Digital Input	DI	Reset Total
Hint Feature	HINT	Disabled
Totalizer	TOTAL	Enabled
Backlight	BACKLIGHT	Enabled
CapTouch	CAPTTOUCH	Normal

Display Menu		
Unit of Measure	UNITS	Rate: GAL/S Total: GAL
Decimal Point Location	DECP	Rate: 2; Total: 1; Grand Total: 0
Comma	COMMA	Enabled
Top Display	TOP	Rate
Bottom Display	BOTTOM	Total

Troubleshooting Tips

Certain sequences of events can cause unexpected results. To solve these issues, it is best to start fresh from factory defaults and use the manual as a step by step programming guide, rather than a random approach to programming. To reset the meter to factory defaults, see *Factory Default Settings* on page 93. In addition, for best results, we recommend using the free [MeterView XL](#) software for all programming needs.

Symptom	Check/Action
No display at all	Check: <ol style="list-style-type: none"> 1. Check if DC power supply is on and it provides 9-30 VDC to the meter. 2. If DC or battery power is OK, the meter might be off: Press & hold the menu key to turn it on; follow the on-screen instructions. 3. If battery powered, check if the LCD is in sleep mode: Press & hold any key for more than 3 seconds to wake-up. 4. If battery powered, check if the meter is off: Press & hold the Menu key for 5 seconds to turn the meter on.
Not able to change setup or programming, LOCKE is displayed	The meter is password-protected. Enter the correct five-digit password to unlock or the Master Password of 50865 to temporarily unlock the meter. To remove the password go to the Advance menu and enter 0000 for the password.
Meter display flashes: 1. 99999 2. --9999	Check that the number of digits required for the scaled value does not exceed the maximum digits for the display. If it does, try adjusting the decimal point location for less precision or changing the PV display to the bottom display.
Display is unstable	Check: <ol style="list-style-type: none"> 1. Input signal stability and value. 2. Display scaling vs. input signal. 3. Increase the low gate setting in the Advance menu, this will allow more time to average the input signal.
Display response is too slow	Check the low gate setting in the Advance menu.
Display reading is not accurate	Check: <ol style="list-style-type: none"> 1. Confirm the flowmeter K-Factor value 2. Check the input scaling
Display does not respond to input changes, reading a fixed number	Check display assignment. It might be displaying max, min, or set point.
Display shows: MAX, MIN, RATE, TOTAL, or TOT and a number	Display has been locked. Press Enter to unlock the display readings.
Relay operation is reversed	Check fail-safe settings in <i>Output</i> menu
Relays do not respond to signal	Check: <ol style="list-style-type: none"> 1. Relay action in <i>Output</i> menu 2. Set and reset points 3. Check manual control menu
If the display locks up or the meter does not respond at all	Cycle the power to reboot the microprocessor.
CapTouch buttons do not respond	<ol style="list-style-type: none"> 1. If hand-symbol is flashing, multiple buttons were touch at the same time, wait a few seconds until the hand symbol goes off. 2. If <i>Delayed</i> mode has been set, press & hold any button for 5 seconds, the buttons should respond normally. 3. If the slide switch on the display module is in the Lock position, move the switch to the Unlock position; see <i>Turning Off CapTouch Buttons</i> on page 40.
Total and/or Grand Total do not reset	Check: <ol style="list-style-type: none"> 1. Total / Grand Total not password protected 2. Grand Total set to non-resettable (this cannot be overridden) 3. Total / Grand Total manual reset disabled. Check Advanced Total and Grand Total reset settings and Enable manual reset.
Other symptoms not described above	Call Technical Support for assistance.

Contact Precision Digital

Technical Support

Call: (800) 610-5239 or (508) 655-7300

Email: support@predig.com

Sales Support

Call: (800) 343-1001 or (508) 655-7300

Email: sales@predig.com

Place Orders

Email: orders@predig.com

For the latest version of this manual please visit

www.predig.com

PRECISION DIGITAL CORPORATION

233 South Street • Hopkinton MA 01748 USA

Tel (800) 343-1001 • (508) 655-7300

www.predig.com

