

PD6000 PROVu Dual-Line 6-Digit Process Meter

Data Sheet



PROVu
SERIES

SUPER-BRIGHT LEDs
Our Brightest Display Ever

MeterView Pro
Instalación por USB



- 1/8 DIN Digital Panel Meter with NEMA 4X, IP65 Front
- 0-20 mA, 4-20 mA, 0-5 V, 1-5 V, and ± 10 V Field Selectable Inputs
- Dual-Line 6-Digit Display, 0.6" (15 mm) & 0.46" (12 mm)
- Isolated 24 VDC @ 200 mA Transmitter Power Supply
- 2 or 4 Relays with Interlocking Capability + Isolated 4-20 mA Output Options
- Free PC-Based MeterView Pro USB Programming Software
- No Assembly Required
- Optional SunBright Display Models for Outdoor Applications
- Operating Temperature Range: -40 to 65°C (-40 to 149°F)
- UL & C-UL Listed. E160849; 508 Industrial Control Equipment
- Input Power Options: 85-265 VAC or 12-24 VDC
- Display Input in Two Different Scales - Great for Level Applications
- Multi-Pump Alternation Control
- Round Horizontal Tank Formula; Just Enter Diameter & Length
- 32-Point, Square Root, or Exponential Linearization
- Programmable Display, Function Keys & Digital Input
- External 4-Relay & Digital I/O Expansion Modules
- RS-232 & RS-485 Serial Communication Options with Modbus RTU
- Light/Horn & Button Accessory
- Control Station Accessory For Remote Operation of PROVu
- Stainless Steel Sun Hood Accessory Available
- 3-Year Warranty



PROVu meter mounted in PDA2301 enclosure with PDA18DINSH Sun Hood and MOD-LH Light/Horn accessory. See page 16 for details.

TABLE OF CONTENTS

OVERVIEW	3
ISOLATED TRANSMITTER POWER SUPPLIES	4
ADVANCED DISPLAY FEATURES	5
QUICK & EASY SCALE & PROGRAMMING METHODS	6
4-20 MA OUTPUT & RELAYS.	9
SIGNAL INPUT CONDITIONING	12
DIGITAL COMMUNICATIONS.	14
FIELD EXPANSION MODULES	14
PHYSICAL FEATURES	15
VIDEOS TO WATCH	16
OPERATIONAL FEATURES	16
NEMA 4 & 4X FIELD ENCLOSURES	20
LIGHT/HORN & BUTTON MOUNTED TO ENCLOSURE	21
DIMENSIONS	24
CONNECTIONS	24
SPECIFICATIONS	25
ORDERING INFORMATION	27

OVERVIEW

Front

Connections

- Form C (SPDT) relays
- Two isolated supplies available even on 12/24 VDC input power models
- Removable terminal blocks
- 2 or 4 relays + isolated 4-20 mA output option

- Universal 85-265 VAC or 12/24 VDC input power
- Voltage or current inputs
- No jumpers needed for V/mA input selection
- M-Link for adding expansion modules
- Digital input (F4)

The Only Process Meter You Will Ever Need

Front, back and in between, the PROVu meter boasts specifications, features and functionality that make it the only 1/8 DIN process meter you will ever need. The number one feature that makes the PROVu such a useful device is its built-in 24 VDC power supply to drive the transmitter as illustrated by the above diagram. This feature not only saves the cost of an external power supply, but also greatly simplifies wiring. In addition, there is a second 40 mA power supply provided with the 4-20 mA output option, evident also in the above diagram.

The picture above illustrates several other reasons why the PROVu is the only process meter you will ever need. First off, is the NEMA 4X rated front panel which means you can install

the PROVu in panels exposed to moisture, dust and other adverse conditions. The picture also points out that the PROVu is available with an optional Sunbright display which means you can install and read the PROVu in direct sunlight. The next thing to notice is the 6-digit dual-line display that can display numbers up to 999,999 on the upper line and show either a tag or the input in a different scale on the lower line.

Other key features include four relays and 4-20 mA output option, advanced signal input conditioning like automatic round horizontal tank linearization, function keys, pump alternation capability, and Modbus RTU serial communications. Finally all these features and capabilities can easily be programmed with free MeterView Pro PC-based software.

ISOLATED TRANSMITTER POWER SUPPLIES

24 V @ 200 mA Transmitter Power Supply

One of the most useful standard features of the AC powered PD6000 is its built-in isolated, 24 V @ 200 mA power supply to power the transmitter. This feature saves money by eliminating an external power supply and also simplifies wiring by reducing the number of devices in the loop. It can be configured for 5, 10, or 24 V (default) by means of a simple internal jumper. This power supply is even available on meters that are powered from DC power (24 V @ 100 mA). To use an external power supply instead of the internal power supply, simply make connections to different terminals on the PROVu. The following diagrams illustrate how to wire the PROVu so it will power the transmitter:

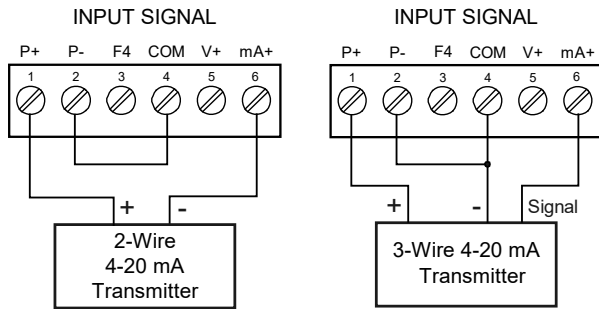

24 V @ 40 mA 4-20 mA Output Power Supply

Not only can the PROVu power the 4-20 mA input signal, but an additional power supply of 24 V @ 40 mA is provided with the 4-20 mA output option to power the 4-20 mA output.

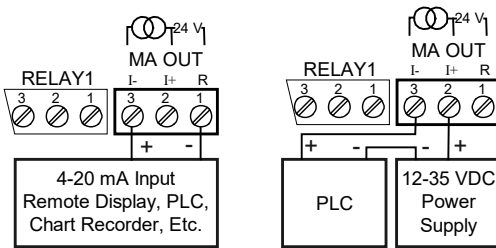

Resettable Fuse Prevents Current Overload

Another very useful aspect of the PROVu is that the current input is protected against current overload by a resettable fuse. The fuse limits the current to a safe level when it detects a fault condition, and automatically resets itself when the fault condition is removed.

Other Uses for the Transmitter Power Supplies

The most common use for these two power supplies is for the 200 mA transmitter power supply to power the field transmitter and 40 mA power supply to power the 4-20 mA output from the meter. However, since these two power supplies are isolated they can be used in other ways. For instance, some level transmitters require the use of a heated lens. The PROVu's 200 mA power supply could be used to power the heated lens and PROVu's 40 mA power supply could be used to power the 4-20 mA input.

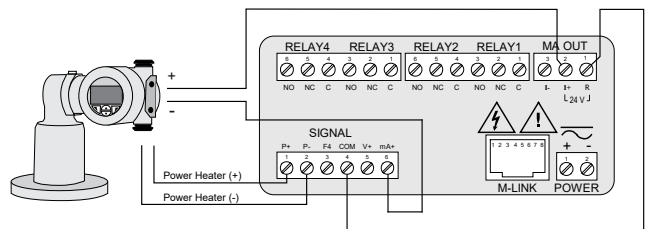

PROVu Powers Both Heater and 4-20 Output

External Power Supply for the Loop

For applications that require an external transmitter power supply, the same PROVu is used and merely wired in a different fashion as the following diagrams illustrate:

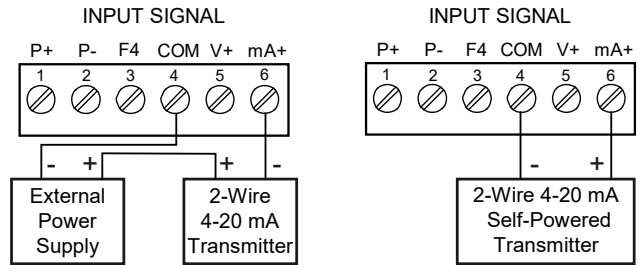

PDA1024-01 24 VDC Transmitter Power Supply

Precision Digital offers the PDA1024-01 for applications that require more than the 200 mA power that the PROVu can provide.



Specifications

Output Voltage: 24 VDC ±10% @ 1.5A rated current
Dimensions: 1.40" x 3.50" x 2.10"
 (35 mm x 90 mm x 54.5 mm) (W x H x D)

ADVANCED DISPLAY FEATURES

Dual-Line Makes All the Difference

The upper display can be programmed to indicate PV, maximum (peak), minimum (valley), alternating maximum/minimum, one of eight alarm set points, or Modbus input. The lower display can be configured to display engineering units, set points, user defined messages, or simply turned off.

The PROVu's dual-line display makes all the difference both when programming the instrument and when using it in the field. When programming the instrument, the dual line display prompts for the needed information and also helps you keep track of where you are in the setup process. When using the instrument, the dual line display provides more information such as displaying the input in two different scales like height and volume for a level application. We call this the Dual-Scale feature.

Programming Assistance

The PROVu's dual-line display makes programming the instrument much easier because the lower line prompts for the needed information and also helps you keep track of where you are in the setup process.



The PROVu is prompting for the value for Input 2 and displaying the default value of 20.00 mA. The "2" in 20.00 is brighter than the rest of the digits indicating that it is the number that will be changed by the Up and Right arrows.



The PROVu is now prompting for what the user wants Display 2 to be; that is the value that corresponds to 20 mA. In this case Display 2 is currently set to 95.00.

Bright & Optional Super-Bright Display

The standard PROVu's display is bright enough for most applications, including moderate sun exposure. However, for direct sunlight exposure the PROVu is available with super-bright LEDs that make it possible to read the PROVu even in direct sunlight. Both versions of the PROVu have eight levels of adjustable intensity.

Rounding Feature for Even Steadier Display

The rounding feature is used to give the user a steadier display with fluctuating signals. It causes the display to round to the nearest value according to the rounding value selected (1, 2, 5, 10, 20, 50, or 100). For example, with a rounding value of 10, and an input of 12346, the display would indicate 12350.

Dual-Scale Display Feature

The PROVu PD6000 has a rather unique, and very flexible dual-scale capability. This is of particular value in level applications where a second scaled display can represent the measured input in a different form (i.e. gallons & height). Both displays are independently scaled and are based on the 4-20 mA input signal. Beyond level, this function has been used for pressure & force, current & power, feet & meters, GPM & CFM, and more.



Gallons & mA



Gallons & Height



Gallons & Percent



Gallons & Head PSI

MeterView Pro can be used to program the PROVu to display the input in two different scales:

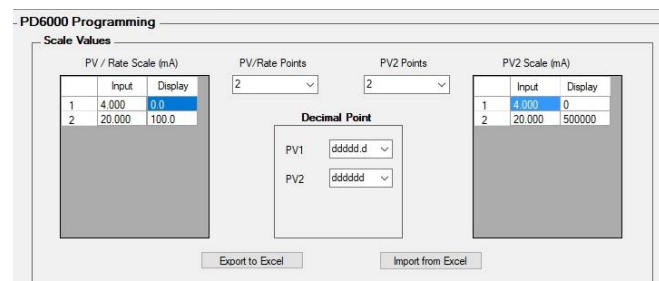

toggling Between Reading & Units with Tag

The PROVu can also be programmed so the upper line toggles between the reading and units and the lower line displays a tag. For instance, the upper line toggles between 9500 and Gal and the lower line displays Tank 1.



Other Uses for Lower Line

The lower line can also be used indicate units, a tag, or even a setpoint as the following pictures illustrate:



Volume in Tank



Gallons & Setpoint



Level in Feet



Pressure Indication

QUICK & EASY SCALE & PROGRAMMING METHODS

The PROVu can be programmed either via the front panel push buttons or free, PC-based MeterView Pro software. MeterView Pro is resident on the PROVu and is accessed by a provided USB cable, so it is by far the easiest way to program the PROVu. The PROVu can be calibrated either by applying a known signal or scaled by entering a desired value with the front panel buttons or MeterView Pro software. Most customers will use the scaling method because it is simpler and does not require a calibrated signal source. Selecting the input to be current or voltage is done with the front panel buttons or MeterView Pro software. Once programming is completed it can be locked with a password.

Free PC-Based MeterView Pro USB Programming Software & Cable

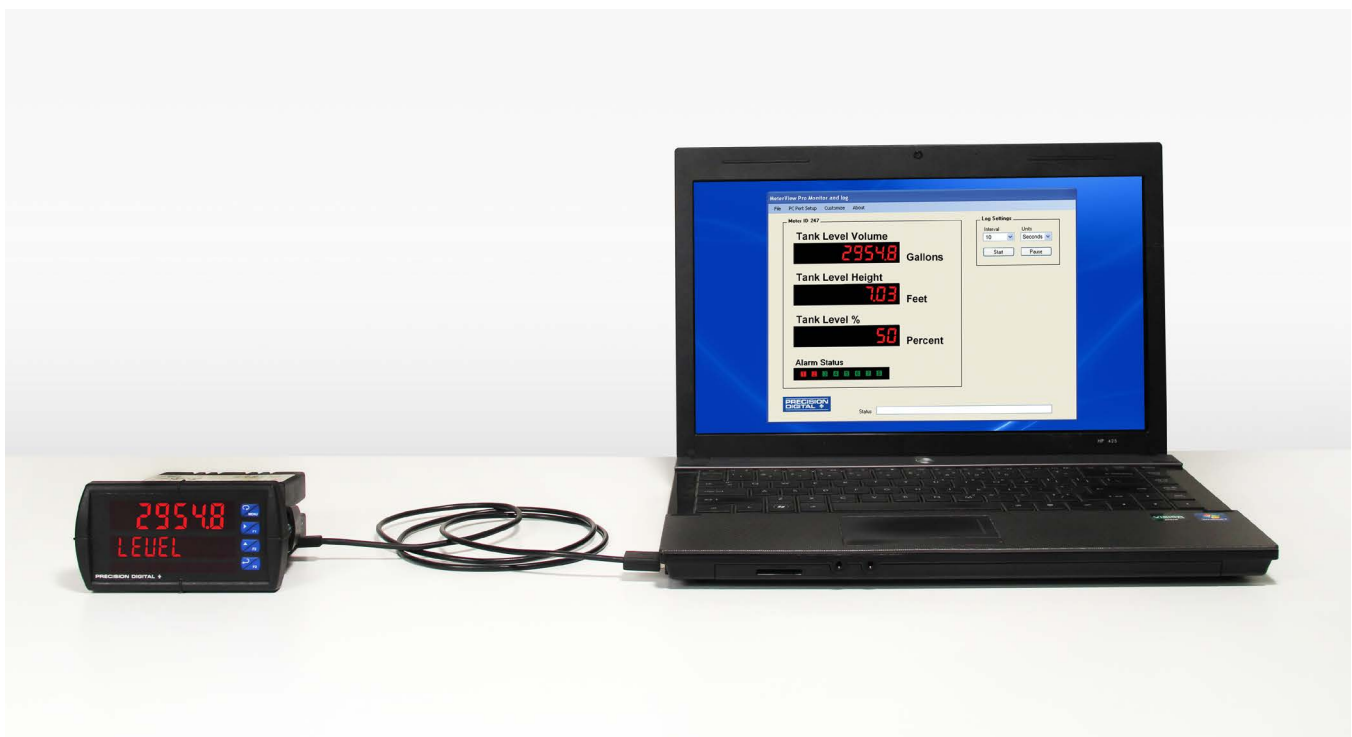

The PROVu comes preloaded with free MeterView Pro programming software that connects and installs directly to your PC with a standard USB cable, also provided free with each instrument. This eliminates the need to insert CDs, install drivers, or download software from the internet. When you connect your PROVu to your PC, MeterView Pro is downloaded to your PC, the software automatically selects the model you are programming, and you're ready to start programming immediately. Further simplifying the programming process, the

PROVu can be powered from the USB port, so no need to apply external power while programming your meter. In addition to programming, the software will also allow you to monitor, and datalog a PROVu using your PC. You can also generate and save programming files for later use.

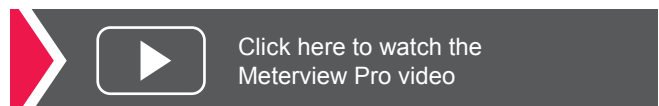

Setup Screen

- Select Voltage or Current Input
- Activate Dual-Scale (Level) Function
- Select Decimal Point
- Set Line 1 Display Parameters
- Set Line 2 Display Parameters
- Set Analog Output Values
- Enable Manual Control
- Test Relays & Digital Outputs

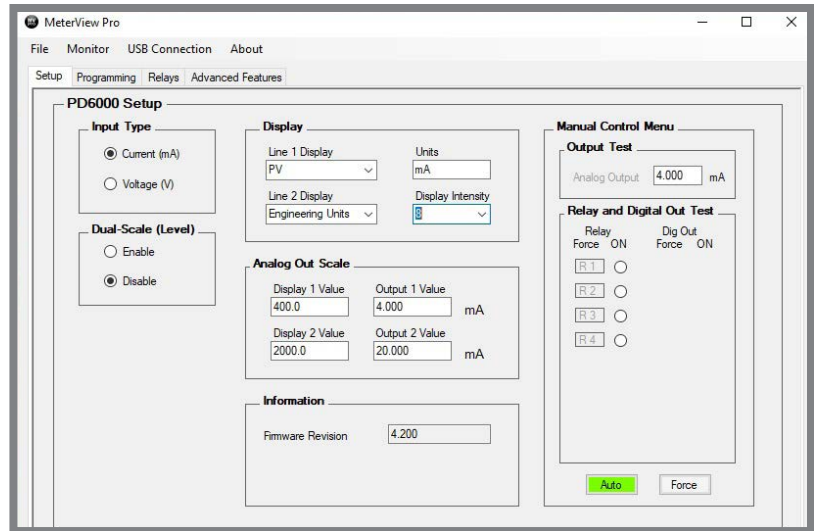

Programming Screen

- Set Scale Values
- Set the Number of Points (up to 32)
- Import from Excel
- Export to Excel

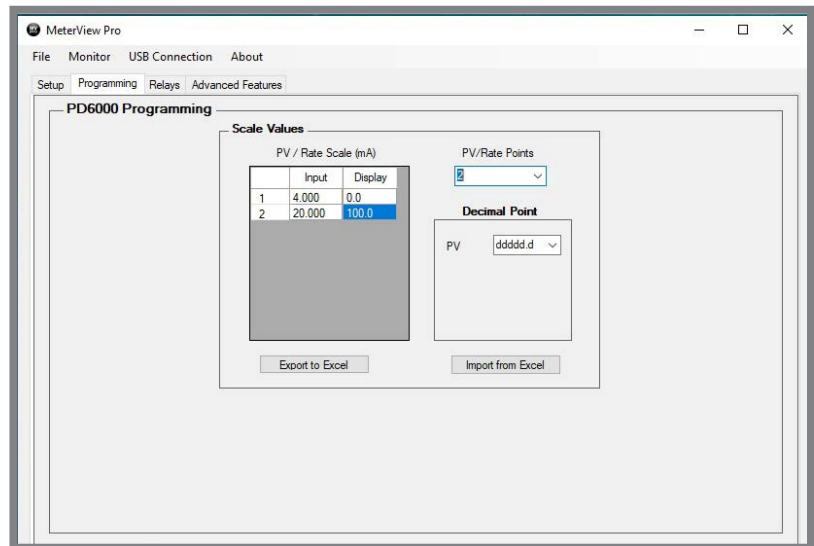

Relays Screen

- Greatly Simplifies Programming a Variety of Relay Features
- Set Relay Action
- Set Sampling Time
- Set Set & Reset Points
- Set On/Off Time Delays
- Set Fail Safe Operation
- Set Input Break Relay Action

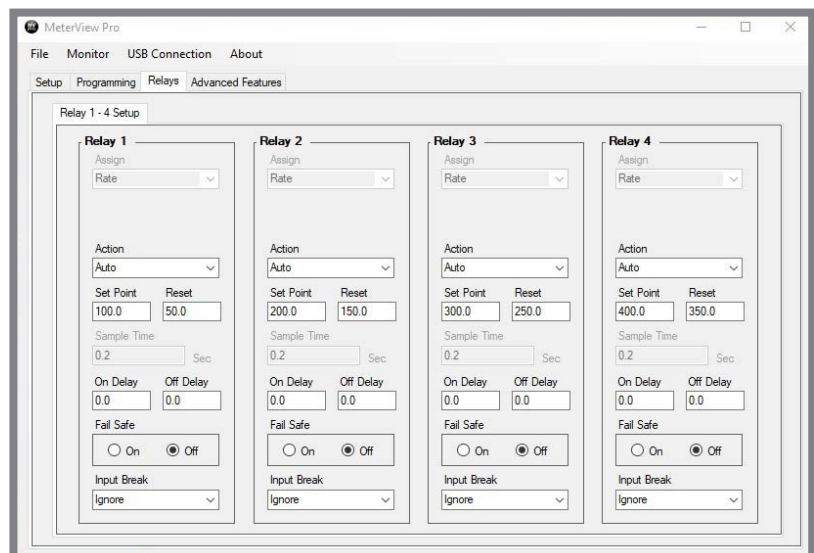

Save/Open Configuration

At the bottom of most MeterView screens are two tabs:

1. **Get Meter Data:** This reads the programming of the meter that is currently connected to the PC.
2. **Send Meter Data:** Clicking this button, sends current MeterView programming to the meter.



The configuration file can be sent or retrieved from the directory of your choice. This makes it very easy to program multiple meters with the same programming. It is also a great backup utility as well.

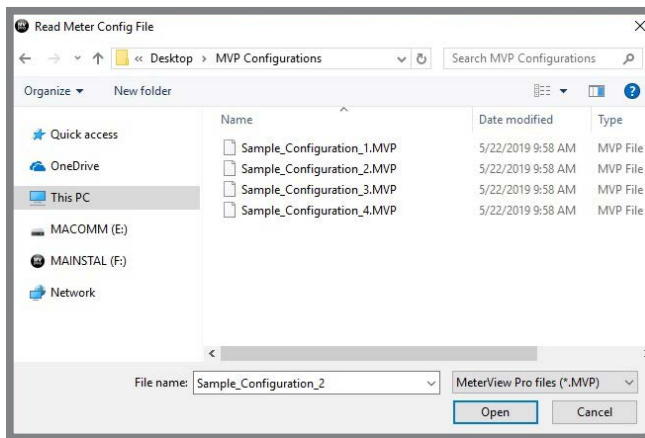

Specifications

System Requirements:

Microsoft® Windows® 7/10/11

Communications:

Onboard USB (firmware version 4.0 or higher),
RS-232 Adapter or RS-485 Adapter

Meter Address: 1 - 247

Reports:

- Data logging: Save as CSV file format
- Configuration: Save as PDC file format or print configuration

Baud Rate: 300 - 19,200 bps

Configuration: One meter at a time

Protocol:

Modbus RTU (requires firmware version 4.0 or higher)

**Note: Windows® 32/64-bit operating systems*

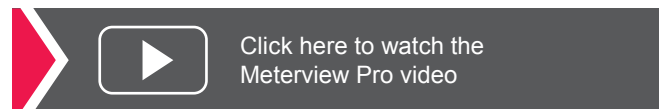

Password Protection

The Password menu is used for programming three levels of security to prevent unauthorized changes to the programmed parameter settings:

Pass 1: Allows use of function keys and digital inputs

Pass 2: Allows use of function keys, digital inputs and editing set/reset points

Pass 3: Restricts all programming, function keys, and digital inputs

4-20 mA OUTPUT & RELAYS

4-20 mA Analog Output

The isolated analog retransmission signal can be configured to represent the process variable (PV), maximum (peak) value, minimum (valley) value, the value for any of the eight relay set points, or Modbus input. While the output is nominally 4-20 mA, the signal will accurately accommodate under- and over-ranges from 1 to 23 mA.

The 4-20 mA output can be reversed scaled such that 4 mA represents the high value and 20 mA represents the low value. For instance, a 4-20 mA output signal could be generated as the meter went from 100.0 to 0.0.

For applications where the input was linearized by the PROVu, the 4-20 mA output will represent that linearized value.

Connections

The PROVu can provide 40 mA at 24 VDC to power the 4-20 mA output signal or an external power supply can be used:

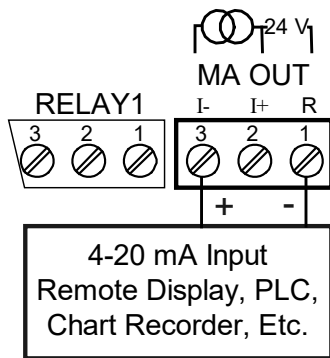

4-20 mA Output Powered by PD6000

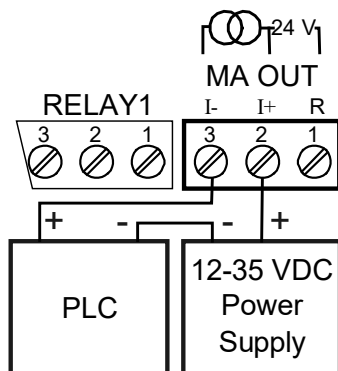

4-20 mA Output Powered by External Power Supply

The internal 24 VDC power supply powering the analog output may be used to power other devices, if the analog output is not used. The I+ terminal is the +24 V and the R terminal is the return.

The 4-20 mA output can either be programmed using the front panel push buttons or free MeterView Pro software.

Front Panel Push Button Programming

The 4-20 mA analog output can be scaled to provide a 4-20 mA signal for any display range selected. No equipment is needed to scale the analog output; simply program the display values to the corresponding mA output signal. The Analog Output menu is used to program the 4-20 mA output based on display values.

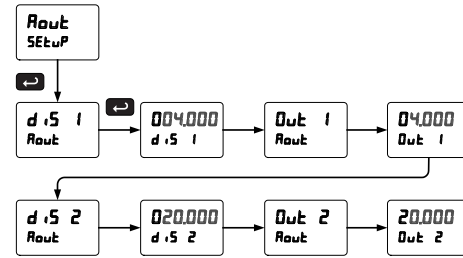

MeterView Pro Software Programming

When a meter is programmed as shown below, the output will be 4.00 mA when the display reads 0 and the output will be 20.00 mA when the display reads 150000.

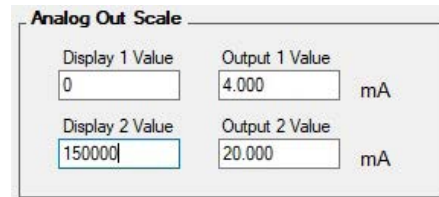

The meter can be set up for reverse scaling as shown below: the output will be 4.00 mA when the display reads 150000 and the output will be 20.00 mA when the display reads 0.

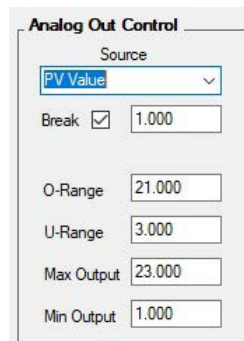
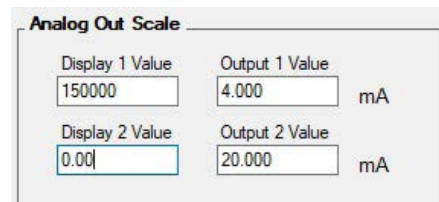

Source: Source for generating the 4-20 mA output (e.g. PV)

Overrange: Analog output value with display in overrange condition

Underrange: Analog output value with display in underrange condition

Break: Analog output value when loop break is detected

Max: Maximum analog output value allowed regardless of input

Min: Minimum analog output value allowed regardless of input

Relays for Alarm & Control Applications

Adding relays to the PROVu meter turns it into a sophisticated alarm device as well as a powerful, yet simple, alternative to a more complicated PLC system for control applications. One such application would be pump control using the PROVu's relays in pump alternation mode. The PROVu can be equipped with up to four 3 A Form C (SPDT) internal relays and an additional four more 3 A Form A (SPST) external relays. Relays are highly user-configurable as the following screen shot from MeterView Pro indicates:

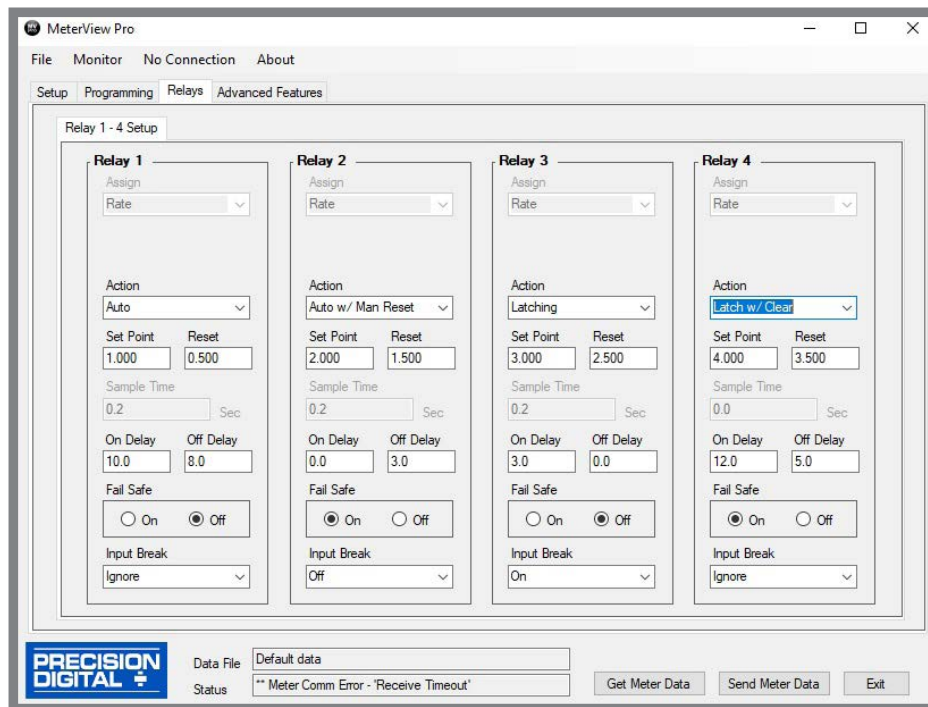

*Values are intended to show programming choices. They are not intended to represent an actual application.

Setting Set and Reset Points (HI / LO Alarms)

All relays are independent of each other and may be programmed as high or low alarms with user desired set and reset points. Setting a set point above a reset point results in a high alarm and setting a set point below a reset point results in a low alarm. Alarms have 0 – 100% deadband and set and reset points may be set anywhere in the range of the meter.

Resetting the Relays (Action in MV Pro)

All relays are independent of each other and may be programmed to reset (*Action* in MV Pro) in the following ways:

- **Automatic:** Alarm will reset automatically once the alarm condition has cleared.
- **Automatic/Manual:** Alarm will reset automatically once the alarm condition has cleared but can also be reset using the F3 front panel button* at any time.
- **Latching:** Alarm must be reset manually and can be done so at any time. Press the F3 front panel button* at any time to clear the alarm.
- **Latching with Reset after Cleared:** Alarm must be reset manually and can only be done so after the alarm condition has cleared. Press the F3 front panel button* after the alarm condition has cleared to reset the alarm.

* Or by connecting an external switch to F4 terminal or with an optional digital input.

Time Delay (On and Off)

In many applications it is desirable to wait before turning off or on a relay – such as waiting for a process to settle before taking action. Each relay on the PROVu can be programmed with independent on and off time delays of 0 to 999.9 seconds to achieve this.

Relays Auto Initialization

When power is applied to the meter, the front panel LEDs and alarm relays will reflect the state of the input to the meter.

Signal Loss or Loop Break Relay Operation

When the meter detects a break in the 4-20 mA loop, the relay will go to one of the following selected actions:

1. Turn On (Go to alarm condition)
2. Turn Off (Go to non-alarm condition)
3. Ignore (Processed as a low signal condition)

User Selectable Fail-Safe Operation

All relays are independent of each other and may be programmed for user selectable fail-safe operation. With the fail-safe feature activated, the relays will transfer to the alarm state on power loss to the meter.

Front Panel LEDs

The meter is supplied with four alarm points that include front panel LEDs to indicate alarm conditions. This standard feature is particularly useful for alarm applications that require visual-only indication.

Manual Output Control

Take control of any output with this feature. All relays can be forced ON or OFF, and the 4-20 mA output signal can be set to any value within its range. When the relays and 4-20 mA output are controlled manually, an LED labeled “M” is turned on and the associated Alarm LEDs (1-8) flash every 10 seconds indicating that the meter is in manual control mode.



Sampling Function (PV Triggered Timed Relay)

The sampling function allows the operator to set a relay as a “sampling” relay. When the PV reaches that set point, it will close that relay’s contacts for a preset period of time (0.1 to 5999.9 seconds). An example of its use may be for beer/ale fermentation. When the batch reaches a certain pH, the relay contacts would close and by some means (light, horn, etc.) alert someone to take a sample, or provide the trigger to automatically take a sample of the batch. The utility of this function can, of course, be expanded beyond sampling and be used whenever a timed relay output closure is required when the PV reaches a certain set point.

Interlock Relay(s)

This function allows a process to use one or more very low voltage input signals or simple switch contacts to control the state of one or more internal “interlock” relays. A violation (i.e. loss of input, open switch, or open circuit) forces one or more N/O interlock relay contacts to open. One input can be used in series with a number of interlock switches, or up to eight inputs can be required to force-on one (or more) internal interlock relays. Requires PDA1044 Digital I/O module or use of on-board digital input F4. Please see *PROVu Series Safety Interlock Feature* whitepaper on our website for more information.

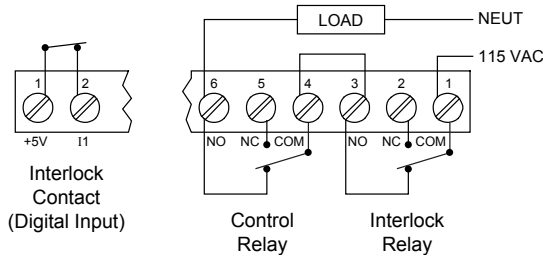

Switching Inductive Loads

The use of suppressors (snubbers) is strongly recommended when switching inductive loads to prevent disrupting the microprocessor’s operation. The suppressors also prolong the life of the relay contacts. Precision Digital offers the PDX6901.

Multi-Pump Alternation

The PROVu can be used as a pump controller when combined with a continuous level transmitter. The most common pump control application is shown below: controlling and alternating two pumps and providing high and low-level alarms. The light/horn accessory can be added to provide visual and audible alarm indication.

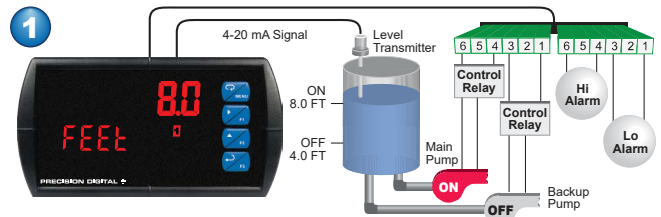

Relay #1 turns the main pump on at 8.0 feet and turns it off at 4.0 feet.

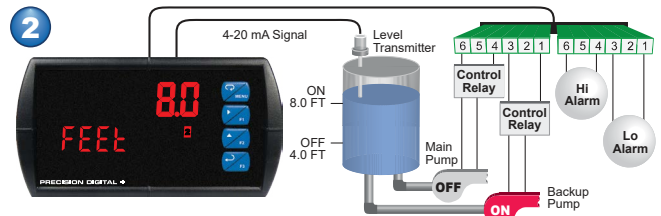

With the Pump Alternation feature activated, the next time the level reaches 8.0 feet, relay #2 transfers and starts the backup pump.

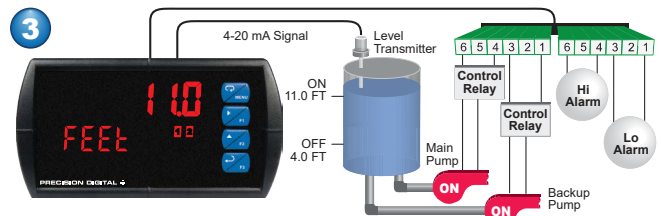

If the backup pump is not able to keep up, and the level reaches 11.0 feet, relay #1 transfers and starts the main pump as well.

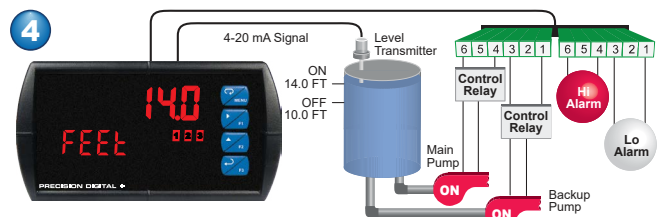

Relay #3 trips the High-Level Alarm at 14.0 feet and resets at 10.0 feet.

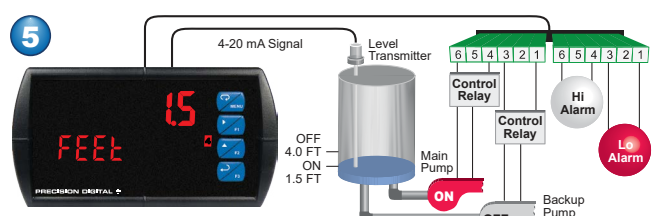

Relay #4 trips the Low-Level Alarm at 1.5 feet and resets at 4.0 feet.

SIGNAL INPUT CONDITIONING

There are many applications in the industrial world that can't be satisfied with simple, two-point linear scaling so the PROVu has advanced linearization capabilities to handle applications like round horizontal tank volume measurement, open channel flow, DP flow, and others. And all of these capabilities are easily programmed using MeterView Pro programming software.

32-Point Linearization

The most common way to linearize a non-linear signal is to break it up into smaller ranges that are more linear than the overall range. The PROVu is available with up to 32 points of linearization and if dual scale feature is used, the second PV can have up to eight points of linearization. The linearization data can be imported from an Excel spreadsheet or can be exported from MeterView Pro to an Excel spreadsheet. The following screen shot from MeterView Pro shows PV1 with 9 points of linearization and PV 2 with 5 points of linearization:

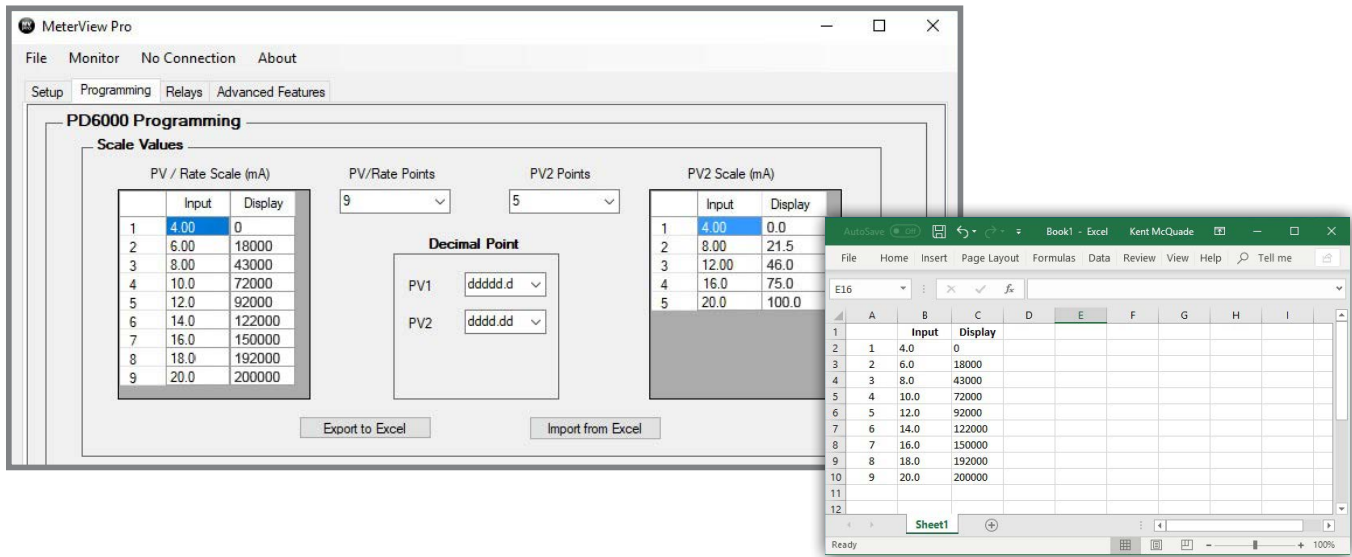

Scale values can also be imported from an Excel spreadsheet.

Specialized Linearization Functions

In addition to the generic 32- and 8-point linearization functions, the PROVu is also available with specialized functions for round horizontal tanks, open channel flow, and DP flow.

Round Horizontal Tank

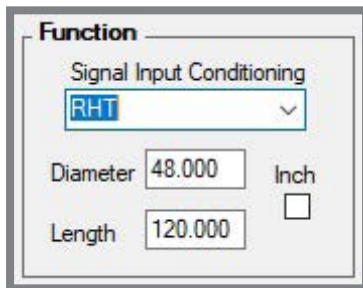

The user enters the diameter and length of a flat-ended round horizontal tank resulting in a display of volume.

Programmable Exponent

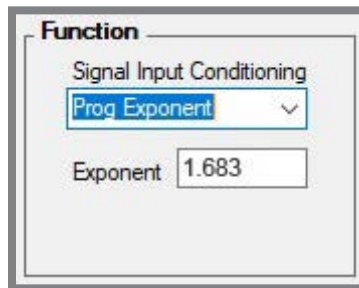

The input is raised to an exponent programmable by the user resulting in a display of open channel flow rate.

Square Root Extraction

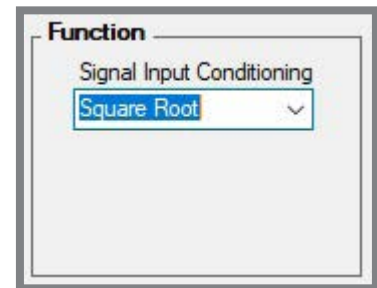

The square root of the input is taken resulting in a display of flow rate.

Round Horizontal Tank Volume Linearizer

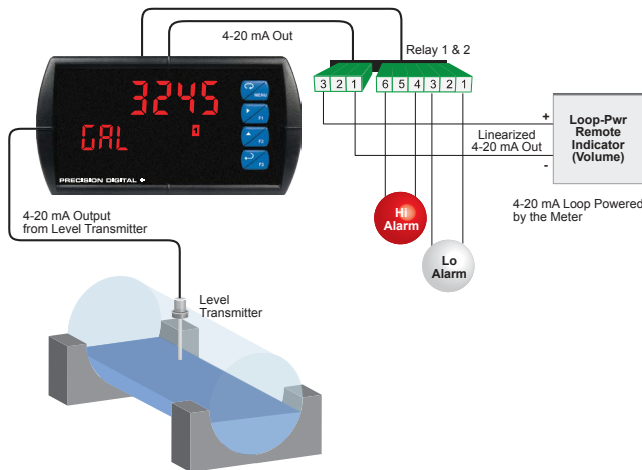

In this application, a level sensor is measuring the height in the round horizontal tank and the PROVu is converting that signal to volume using the RHT function. All the user has to do is input the diameter and length of the tank and the meter converts the signal to volume.

DP Flow via Square Root Extraction

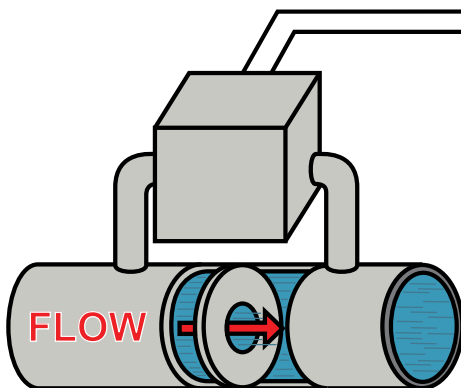

In this application, the PD6000 is displaying flow rate by extracting the square root from the 4-20 mA signal from a differential pressure transmitter. The user selectable low-flow cutoff feature gives a reading of zero when the flow rate drops below a user selectable value.

Linear 4-20 mA Analog Output

For applications where the input was linearized by the PROVu, the 4-20 mA output will represent that linearized value.

Open Channel Flow Rate Indication

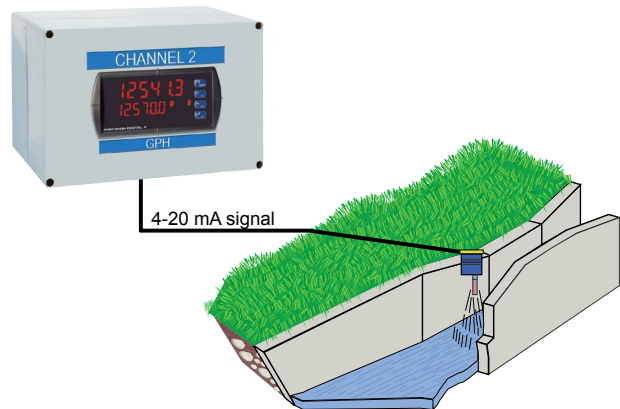

In this application, a level sensor is measuring the height in a weir and the PROVu is converting that signal to flow rate using the programmable exponent function. All the user has to do is input the corresponding exponent for their weir and the meter will convert the signal to flow.

The following information is required for programming the PD6000 for open channel flow rate:

1. The exponent value associated with the flow calculation for the specific weir or flume being used.
2. The zero head, or water depth, mA value from the level transmitter.
3. The mA value from the transmitter for the maximum head, and the flow rate at that level. The level transmitter is normally programmed to provide 20 mA at the maximum head value and flow rate.

Example:

A 120° V-notch weir flow formula for millions of gallons per day is shown below.

$$MGD=2.798 H^{2.5}$$

The exponent component is 2.5.

The level transmitter has been programmed so that at zero head, when the water level is at the base of the V-notch, the output is 4 mA.

The level transmitter has been programmed so that at the top of the V-notch, at 2.00 ft, the output is 20 mA.¹

The coefficient of the flow equation (2.798 in the above example), is not needed for programming the meter; the scaling function of the meter incorporates the coefficient and the head height automatically.

1. *Isco Open Channel Flow Measurement Handbook, Sixth Edition, ed. Diane K. Walkowiak, M.A. (Teledyne Isco, Inc., 2006), 168-169.*

DIGITAL COMMUNICATIONS

Modbus® RTU Serial Communications

With the purchase of a serial communication adapter, PROVu meters can communicate with any Modbus Master device using the ever-popular Modbus communications protocol that is included in every PROVu. In addition to the typical Modbus capabilities of reading PVs and writing set points, below are some examples of other things that can be done with the meter's Modbus communications:

- Send a 6-character message to lower display upon an event
- Convert a digital value to a 4-20 mA signal
- Remote user control (i.e. change set points, acknowledge alarms)
- Input a Modbus digital PV (in place of analog input)
- Remote override of any or all relays and analog outputs



Modbus PV Input



Remote Message

Click here for more information on the PROVu's Modbus capabilities

Serial Communication Devices

Precision Digital provides a variety of serial communication devices to interface the PROVu meter with other devices. For more information visit predig.com/ProVuSerialDevices.

PDA1232 & PDA1485 Communication Modules

Serial communications on the PROVu meter can be added anytime with external PDA1232 (RS-232) or PDA1485 (RS-485) communication adapters. Free Modbus protocol is included for use with the PROVu serial communications modules.

Serial Adapters & Converters*



PDA1232
PROVu RS-232
Serial Adapter



PDA1485
PROVu RS-485
Serial Adapter



PDA7485-I
RS-232 to RS-422/485
Isolated Converter



PDA8232-N
USB to RS-232
Non-Isolated
Converter



PDA8485-I
USB to
RS-422/485
Isolated Converter

For more info on serial converters click here.

*All adapters and connectors supplied with appropriate cables.

FIELD EXPANSION MODULES

Add functionality to the PROVu in the field with easy-to-install external expansion modules. Add RS-232 or RS-485 communications, I/O modules (up to 2), and 4-relay expansion module. The menu items for these modules do not appear until the module is connected, simplifying the basic menu. Relay and digital I/O modules are shown below with optional DIN rail mounting kit, P/N PDA1002.

PDA1044 I/O Expansion Module

Four digital inputs and four digital outputs are available per expansion module. The PROVu meter will accept two of these modules. External digital inputs can function similarly to the front panel function keys or on-board digital input F4. They can be configured to trigger certain events (i.e. acknowledge/reset alarms, reset max and/or min values, disable/enable all output relays, and hold current relay states), provide direct menu access point, or mimic front panel keys. The I/O module can be used to configure the PROVu remotely, in essence giving the user control of the four front panel push buttons. This feature is particularly useful if the meter is mounted inside an explosion-proof enclosure.

Digital outputs can be used to remotely monitor PROVu's alarm relay output states, or the states of a variety of actions and functions executed by the meter.

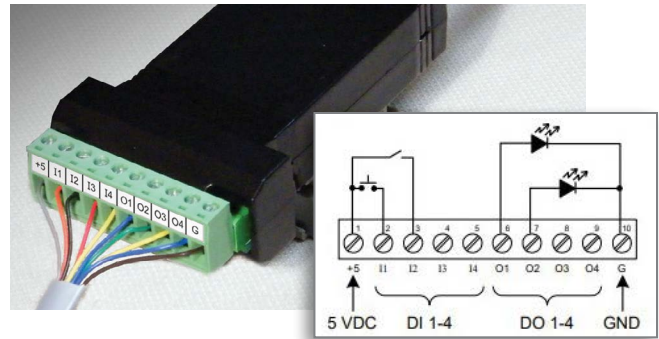

PDA1004 Relay Expansion Module

An external module containing four 3 A Form A (SPST) relays can be added to the PROVu at anytime. Removable screw terminal blocks accept 12 to 22 AWG wire.

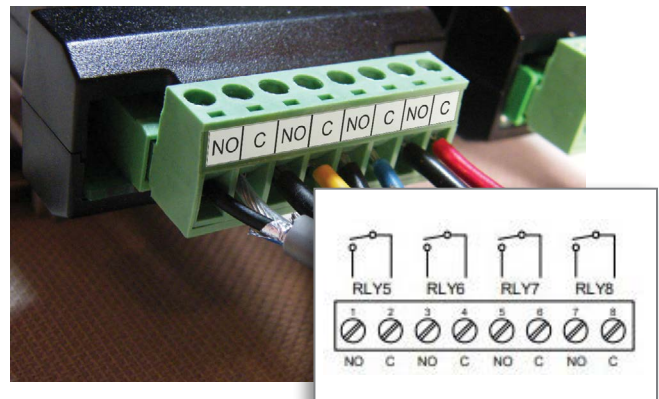

PHYSICAL FEATURES

The PROVU is designed for ease-of-use in industrial applications. Considerations include a NEMA 4X front panel, wide operating temperature range, removable screw terminal connectors, snap in place mounting brackets, forgiving panel cutout requirement, and UL Listing for electrical safety. All of these features are backed by a 3-year warranty.

Type 4X / NEMA 4X Front Panel



Not only does the PROVU's front panel UL Type 4X approval indicate it is waterproof, but it also indicates it is rugged. Part of the UL Type 4X test is to drop a 2 inch solid stainless steel ball from 8 feet on top of the meter's faceplate.

Wide Operating Temperature Range

The PROVU can operate from -40 to 65°C (-40 to 150°F) meaning it can be installed in a wide variety of indoor and outdoor industrial applications. And over this range, the PROVU will drift no more than 0.005% of calibrated span/°C max from 0 to 65°C ambient and 0.01% of calibrated span/°C max from -40 to 0°C ambient.

Removable Screw Terminal Connectors

Industrial applications require screw terminal connections for easy field wiring and the PROVU goes one step further in convenience by making them removable also.



Easy Plug-in Removable Terminal Connectors



Secured-in-Place Rugged Mounting Brackets

If you're installing the PROVU outdoors in the hot or cold weather, the last thing you want to do is fumble around with mounting brackets that don't stay in place. The PROVU's mounting brackets can be easily secured into place and then screwed down to the panel. These brackets are rugged so they can be tightened to the panel to provide a solid NEMA 4X seal.



Easy Secured-in-Place Mounting Brackets

Forgiving Panel Cutout Requirement

The PROVU's bezel has been oversized to allow for not perfectly executed panel cutouts where NEMA 4X seal is not required.

Over-Sized Bezel to Completely Cover Panel Cutouts



UL Listing for Electrical Safety

UL & C-UL Listed: USA & Canada
UL 508 Industrial Control Equipment

UL File Number: E160849

Front Panel: UL Type 4X, NEMA 4X, IP65; panel gasket provided

Low Voltage Directive: EN 61010-1:2010 Safety requirements for measurement, control, and laboratory use

USB Port for Easy Connection to MeterView Pro Free Software



USB cable conveniently plugs into side of PROVU meter

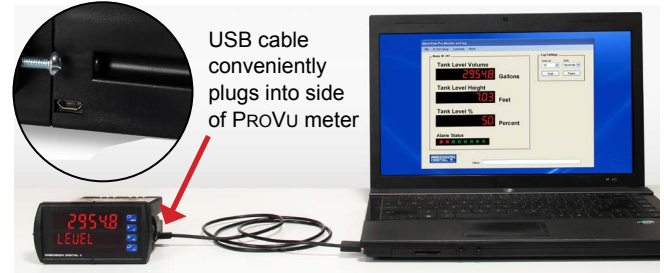

VIDEOS TO WATCH

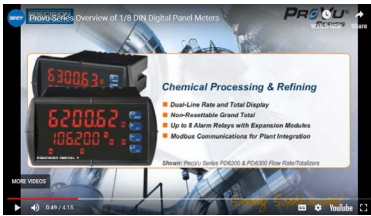

PROVu Series Overview

Learn About All the Meters in the PROVu Series!

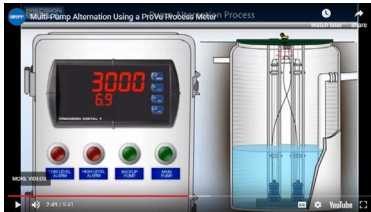

PROVu Multi-Pump Alternation

Learn How to Use the PROVu as a Pump Controller.



PROVu Function Keys

Learn How the PROVu's Function Keys Increase the Utility of the PROVu.



Connect a PROVu to a PC Using MeterView Pro

Learn How Easy it is to Use MeterView Pro Software.

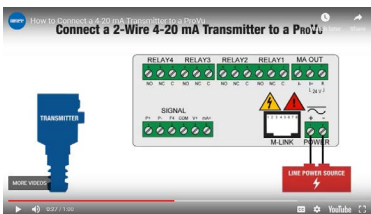

Connect a 2-Wire 4-20 mA Transmitter to a PROVu

Learn How to Connect Your Transmitter to a PROVu.



Introduction to the Helios

Learn About the Large Display Version of the PROVu.

OPERATIONAL FEATURES

Function Keys, F4 Terminal, Digital Inputs

There are three ways the user can interact with the PROVu to perform a variety of useful functions:

1. Three Front Panel Function Keys

The default settings for the function keys are:



Reset Max/Min Reading



Display Max/Min Reading



Acknowledge Relays

2. F4 On-Board Digital Input

The PD6000 includes a digital input as standard. This digital input can operate with the tare, reset tare, or interlock relays feature, force relays on from a signal from a PLC or relay on other equipment, and much more. This is ideal for installations where the meter is inaccessible behind a cover, or where an additional function key is needed for customized operation.

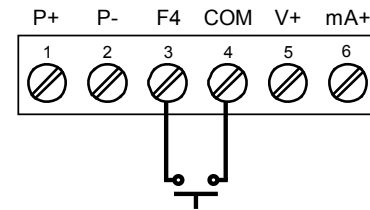

The F4 terminal is particularly useful for wiring up a remote switch to reset the relays as shown here:



3. Optional 4 Digital Input/Output Module PDA1044

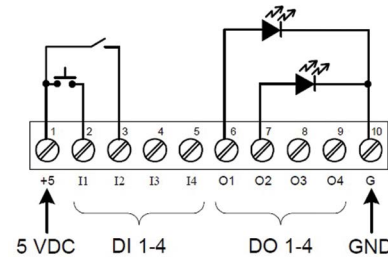

With these three methods, the PROVu can be programmed to trigger certain events (i.e acknowledge relays, reset max and/or min, disable/enable output relays, or hold current relay states), provide direct menu access points and more.

Function Key, Digital Inputs, & Digital Outputs Descriptions

The following table describes the actions that PROVu function keys and digital inputs can be programmed to perform. The table also describes how the digital outputs can be used to remotely monitor the PROVu's alarm relay states, or the states of a variety of actions and functions executed by the meter.

Display	Description	Item
rSt H1	Reset the stored maximum display value	FK, DI, DO
rSt Lo	Reset the stored minimum display value	FK, DI, DO
rSt HL	Reset the stored maximum & minimum display values	FK, DI, DO
tArE	Capture tare and zero the display	FK, DI, DO
rSt tr	Reset captured tare and resume normal operation	FK, DI, DO
rELAY	Directly access the relay menu	FK, DI
SEt 1*	Directly access the set point menu for relay 1 (*through 8)	FK, DI
rLY d	Disable all relays until a button assigned to enable relays (rLY E) is pressed	FK, DI
rLY E	Enable all relays to function as they have been programmed	FK, DI
0 Hold	Hold current relay states and analog output as they are until a button assigned to enable relays (rLY E) is pressed	FK, DI
d Hold	Hold the current display value, relay states, and analog output momentarily while the function key or digital input is active. The process value will continue to be calculated in the background.	FK, DI
Ln1 H1	Display maximum display value on line 1	FK, DI
Ln1 Lo	Display minimum display value on line 1	FK, DI

Display	Description	Item
Ln1 HL	Display maximum & minimum display values on line 1	FK, DI
Ln2 H1	Display maximum display value on line 2	FK, DI
Ln2 Lo	Display minimum display value on line 2	FK, DI
Ln2 HL	Display maximum & minimum display values on line 2	FK, DI
F On 1*	Force relay 1 (*through 4) into the on state. This is used in conjunction with a digital input expansion module to achieve interlock functionality.	FK, DI
ContrL	Directly access the control menu	FK, DI
dISAbL	Disable the selected function key or digital I/O	FK, DI
AcK	Acknowledge all active relays that are in a manual operation mode such as auto-manual or latching	FK, DI, DO
rESEt	Directly access the reset menu	FK, DI
mENu	Mimic the menu button functionality (digital inputs only)	DI
rIGHt	Mimic the right arrow/F1 button functionality (digital inputs only)	DI
uP	Mimic the up arrow/F2 button functionality (digital inputs only)	DI
EntEr	Mimic the enter/F3 button functionality (digital inputs only)	DI
ALm 1*	Provide indication when alarm 1 (*through 8) has been triggered (digital outputs only)	DO

FK: Function Keys DI: Digital Inputs DO: Digital Outputs

Watch video about the programmable function keys, digital inputs, and all the capabilities these features offer on the PROVu Series.

Remote Operation of Front Panel Buttons

The user can operate the front panel buttons from a remote location by using digital inputs programmed in the following manner:

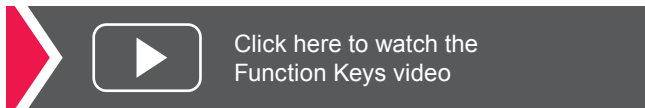
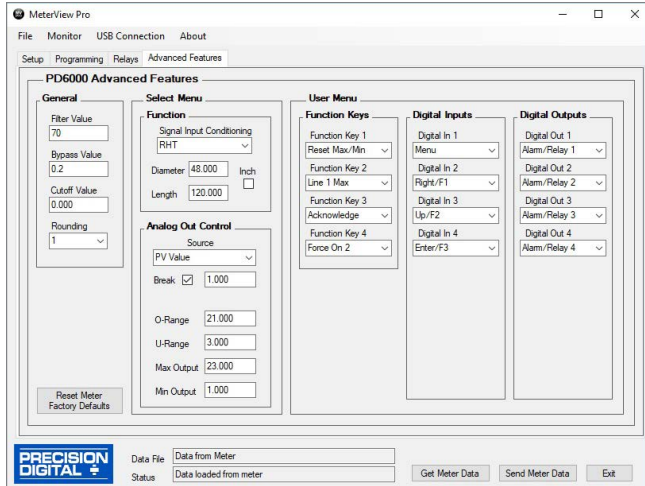

Tare

The tare function zero's out the display. In the case of scale weight, tare is used to eliminate container weight and provide net weight readings. There are two tare functions; Capture Tare and Reset Tare. When the capture tare function is used, the display reading is offset by the displayed amount to make the displayed value zero. This modified display value is the net value. The originally displayed value without the tare offset is the gross value. Both may be chosen as a display option. Reset tare removes the display offset.



Reset tare removes the display offset of the net value, and the gross and net values become the same until a new capture tare is entered.

Max / Min Display

Max/Min (or Peak/Valley) is standard on the PROVu PD6000. Either display can be configured to show either maximum or minimum excursion since last reset. The displays can also be configured to toggle between Max and Min values. Both values can be simply reset from the front panel.

MeterView Pro Monitoring & Datalogging Software

Not only does free MeterView Pro software greatly simplify setup and programming of the PROVu, it can also be used to monitor and datalog your process.

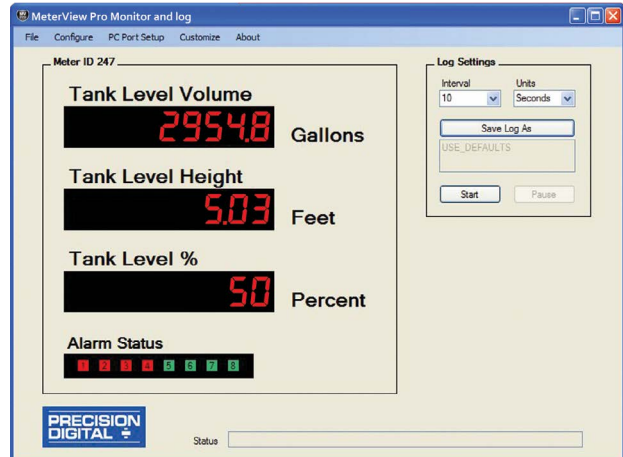

- Custom Tags: i.e. Tank Level Volume
- Custom Units: i.e. Gallons, Feet, Percent
- Alarm Status Indicators

Datalog Report

Collected data logger information can be sent to a CSV file for importing into a spreadsheet program. Below is an example of one such file. Of course, once within the spreadsheet, much can be done to customize the data.

w ProFurnace 3.csv Created 8/10/2010 3:22:37 PM

COMSLogging Rate:1 update every 5Seconds

Date & Time	Tag1	Display	Units	Tag2	Display	Units	Tag3	Display	Units	R1	R2	R3	R4
8/10/2010 3:22	Furn 3	207	Degrees F	MAX	247	Degrees F	MIN	206	Degrees F	Off	On	Off	Off
8/10/2010 3:22	Furn 3	207	Degrees F	MAX	247	Degrees F	MIN	206	Degrees F	Off	On	Off	Off
8/10/2010 3:22	Furn 3	207	Degrees F	MAX	247	Degrees F	MIN	206	Degrees F	Off	On	Off	Off
8/10/2010 3:22	Furn 3	207	Degrees F	MAX	247	Degrees F	MIN	206	Degrees F	Off	On	Off	Off
8/10/2010 3:22	Furn 3	207	Degrees F	MAX	247	Degrees F	MIN	206	Degrees F	Off	On	Off	Off
8/10/2010 3:23	Furn 3	207	Degrees F	MAX	247	Degrees F	MIN	206	Degrees F	Off	On	Off	Off
8/10/2010 3:23	Furn 3	207	Degrees F	MAX	247	Degrees F	MIN	206	Degrees F	Off	On	Off	Off
8/10/2010 3:23	Furn 3	207	Degrees F	MAX	247	Degrees F	MIN	206	Degrees F	Off	On	Off	Off
8/10/2010 3:23	Furn 3	207	Degrees F	MAX	247	Degrees F	MIN	206	Degrees F	Off	On	Off	Off
8/10/2010 3:23	Furn 3	207	Degrees F	MAX	247	Degrees F	MIN	206	Degrees F	Off	On	Off	Off
8/10/2010 3:23	Furn 3	207	Degrees F	MAX	247	Degrees F	MIN	206	Degrees F	Off	On	Off	Off
8/10/2010 3:23	Furn 3	207	Degrees F	MAX	247	Degrees F	MIN	206	Degrees F	Off	On	Off	Off
8/10/2010 3:23	Furn 3	207	Degrees F	MAX	247	Degrees F	MIN	206	Degrees F	Off	On	Off	Off
8/10/2010 3:23	Furn 3	207	Degrees F	MAX	247	Degrees F	MIN	206	Degrees F	Off	On	Off	Off
8/10/2010 3:24	Furn 3	207	Degrees F	MAX	247	Degrees F	MIN	206	Degrees F	Off	On	Off	Off
8/10/2010 3:24	Furn 3	207	Degrees F	MAX	247	Degrees F	MIN	206	Degrees F	Off	On	Off	Off

Relay Control

Relays can be controlled from MeterView Pro for testing purposes. This is commonly done to determine whether the relays are functioning properly. In the *Setup* window, under *Relay and Digital Out Test* you have the option of selecting the relays you want in an ON state or OFF state and also whether you want to leave the relays in manual control or to return them to automatic operation.

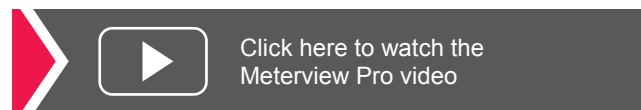

Four-Position Control Station for Remote Operation of PROVu Buttons

The PD6000's four programming and operations buttons can be remotely controlled by using the PDA2364-MRUE 4-button control station accessory as shown in the diagram below.

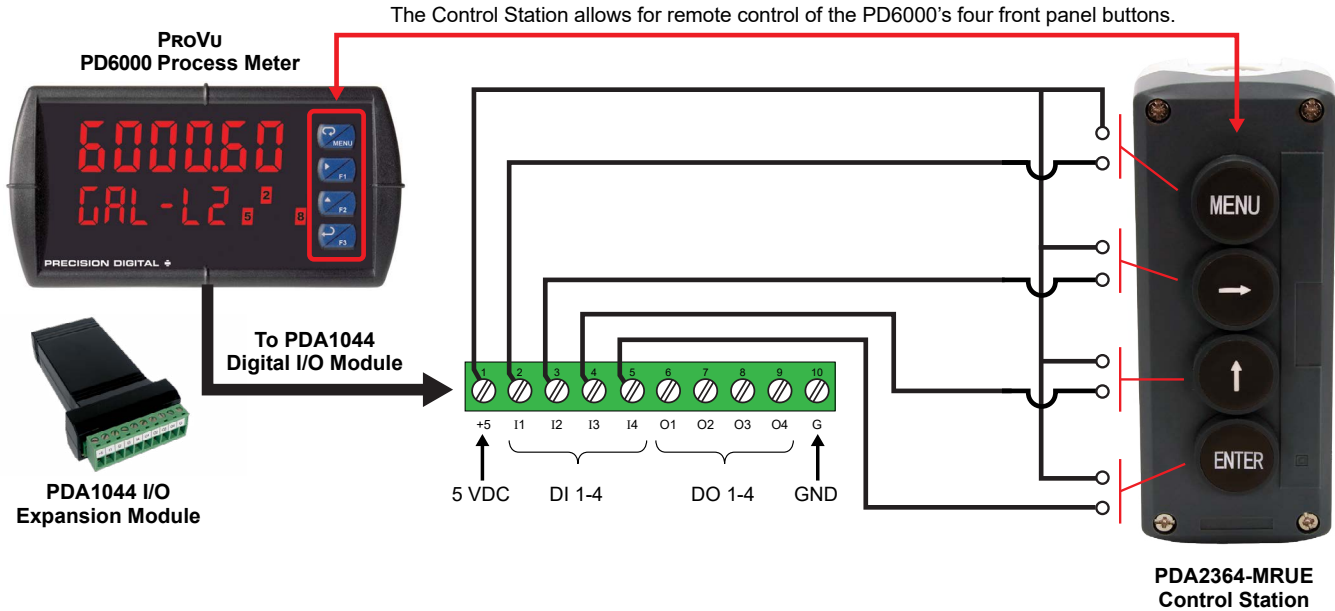

Plastic Control Stations For The ProVu PD6000

The PDA2360 series of plastic control stations provide a convenient way to remotely control devices such as Precision Digital's PROVu PD6000. The PDA2364-MRUE four-position control station mimics the PROVu's four front panel buttons: Menu, Right Arrow, Up Arrow, and Enter. The PDA2360-E is an emergency stop button, the PDA2361-A is used to acknowledge an alarm, and the PDA2361-Q is to silence an alarm.



- Complete Pre-Assembled Stations
- Normally Open (NO) Spring Return Plastic Bezel Pushbuttons
- Trigger Action Turn to Release Pushbutton (PDA2360-E only)
- IP65 / NEMA 4, 4X and 13 Rated
- Four-Position Control Station for Remote Operation of PROVu Buttons
- Wall Mountable

PDA2360 Series Control Stations	
Model	Description
PDA2360-E	Emergency Stop Button
PDA2361-A	1 Black Ack Button
PDA2361-Q	1 Black Silence Button
PDA2364-MRUE	4 Black Buttons: Menu, Right, Up, Enter

NEMA 4 & 4X FIELD ENCLOSURES

Precision Digital offers a variety of rugged enclosures that provide a high degree of protection against harsh operating environments. Thermoplastic and stainless steel NEMA 4X, and painted steel NEMA 4 enclosures for up to 10 PROVu meters are available. In addition, Precision Digital offers a Light/Horn that can be mounted to most of these enclosures to provide visual and audible indication of alarms. Many enclosures also have sufficient space to house Precision Digital's model PDA1024-01 24 V power supply to provide power to transmitters and sensors that require more than the 200 mA that the PROVu can provide.



Need help selecting the right enclosure?
www.predig.com/esu



Download free 3-D CAD files of these instruments to simplify your drawings!

predig.com/documentation-cad

Plastic Enclosures (Externally Mounted)

PDA2300 Series (Covers with Hinge & Hasp)

This is Precision Digital's most economical line of enclosures for the PROVu. The meter mounts through a hinged cover with a SS hasp allowing for easy access to meter wiring. Enclosures are available for 1 through 10 PROVUs. The enclosure is large enough to mount the PDA1024-01 24 V transmitter supply in.



PDA2301



PDA2310

PDA2800 Series (Covers with Screws)

This is Precision Digital's smallest line of enclosures for the PROVu. The meter mounts through the cover that screws to the base of the enclosure. Available for 1 and 2 PROVUs.



PDA2811



PDA2812

Plastic Enclosures (Internally Mounted)

PDA3400 Series (Covers with screws)

This is Precision Digital's only line of enclosures for the PROVu where the meter is fully housed inside the enclosure. Enclosures are available for 1, 2 and 3 ProVus.



PDA3407



PDA3412

Stainless Steel Enclosures (Externally Mounted)

PDA2600 Series (Covers with Hinge & Hasp)

This is Precision Digital's stainless steel line of enclosures for the PROVu. The meter mounts through a hinged cover with a SS hasp allowing for easy access to meter wiring. Enclosures are available for 1 through 6 PROVUs.



PDA2604-1



PDA2606

Steel Enclosures (Externally Mounted)

PDA2700 Series (Covers with Hinge & Hasp)

This is Precision Digital's painted steel line of enclosures for the PROVu. The meter mounts through a hinged cover with a hasp allowing for easy access to meter wiring. Enclosures are available for 1 through 6 PROVUs.



PDA2704-1



PDA2706

LIGHT/HORN & BUTTON MOUNTED TO ENCLOSURE

PROVu Meter in a PDA2301 Enclosure with MOD-LH Light/Horn and Button.
Enclosure & MOD-LH Sold Separately. Assembly Required.

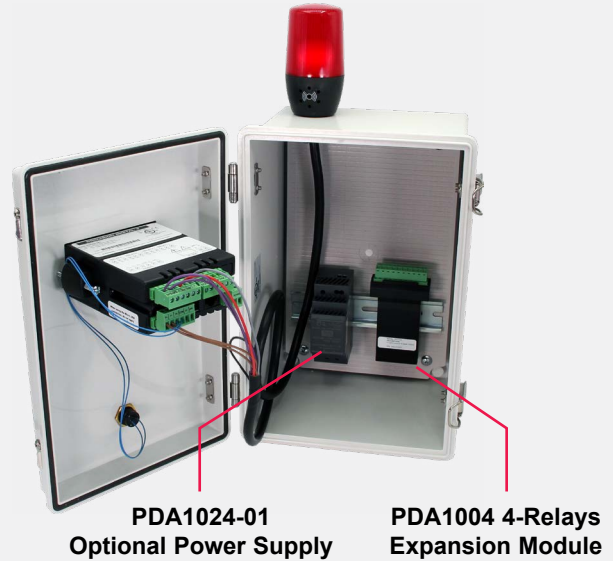

Overview

Precision Digital offers a wide variety of NEMA 4 and NEMA 4X enclosures that can be equipped with MOD-LH Light/Horn and Button. When MOD-LH is ordered, the accompanying enclosure on the order comes with the holes pre-drilled for the Light/Horn and the Button and the user performs the mounting and wiring. Meter and enclosure are sold separately. The Light/Horn and the Button can also be ordered as separate items and the user performs all hole-drilling, mounting and wiring as desired. The light and horn can be controlled independently of each other via separate relays on the PROVu meter; and since the meter's relays can be reset in a variety of ways, there are several ways the Light/Horn option can operate. For instance, the horn can be programmed to silence at any time via the Button or F3 front panel button on the PROVu, and light to reset automatically when the alarm clears as the following table illustrates:

Relay #	Connected to	Default Reset Mode
1	Flashing Light ⁽¹⁾	Auto reset
2	Horn	Silence with Button at any time
3	User Device	As user desires
4	User Device	As user desires

1. Light can be wired to flash or stay steady on.
2. See page 10 for additional ways the relays can be programmed

Note: The Light/Horn accessory is powered from the 200 mA transmitter power supply; so when it is installed, there is less power available for the transmitter. See MOD-LH Light/Horn, Transmitter Power Supply specification on page 26 for details.

Dimensions

Units: Inches (mm)

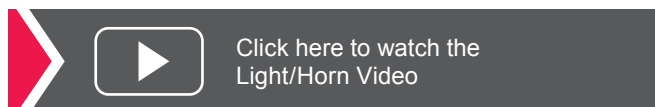
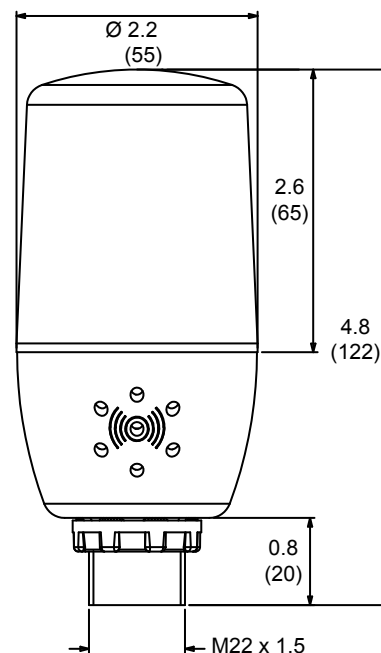

PDA1024-01 24 VDC DIN Rail Power Supply

For transmitters and sensors that require more than the 200 mA power that the PROVu can provide, use Precision Digital's PDA1024-01 24 VDC power supply as shown here.



**PDA1024-01 Power Supply
Installed in a PDA2301 Enclosure**



**PDA1024-01
24 VDC Power Supply**



Input Voltage	85 ~ 264VAC 120 ~ 370VDC
Output Voltage	24 VDC ±10% @ 1.5A rated current
Input Frequency	47 ~ 63Hz
AC Current	0.88A/115VAC 0.48A/230VAC
Connections	Two terminals provided for +V and -V to simplify wiring of multiple devices
Operating Temperature	-20° to 60°C
Safety Standards	UL60950-1, TUV EN60950-1 Approved, Design refer to EN50178
EMC	Compliance to EN55011, EN55022 (CISPR22) Class B, EN61000-3-2, -3 EN61000-4-2, 3, 4, 5, 6, 8, 11, ENV50204, EN55024, EN61000-6-1, EN61204-3 Light industry, Criteria A
Dimensions	1.40" x 3.50" x 2.10" (35 mm x 90 mm x 54.5 mm) (W x H x D)

Wiring Connections for MOD-LH Models

The following diagrams are for MOD-LH models with a single color light. See MOD-LH manual for wiring connections for MOD-LH5CB1 and MOD-LH3CB1-RYG models.

Using PROVu's Internal Power Supply

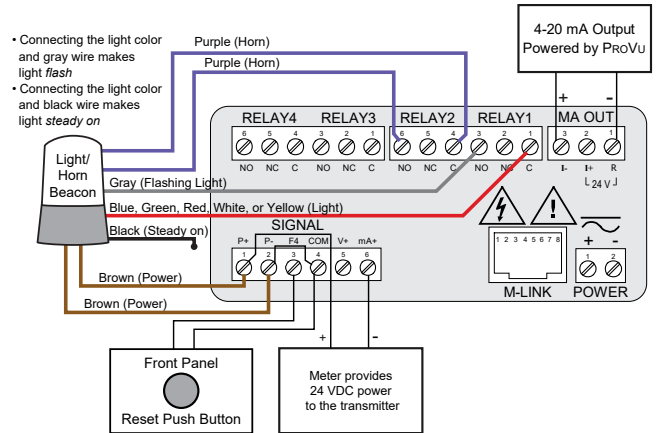

- Form C (SPDT) relays
- Two isolated supplies available even on 12/24 VDC input power models
- Removable terminal blocks
- 2 or 4 relays + isolated 4-20 mA output option
- Universal 85-265 VAC or 12/24 VDC input power
- Voltage or current inputs
- No jumpers needed for V/mA input selection
- M-Link for adding expansion modules
- Digital input (F4)

Using External Power Supply (PDA1024-01)

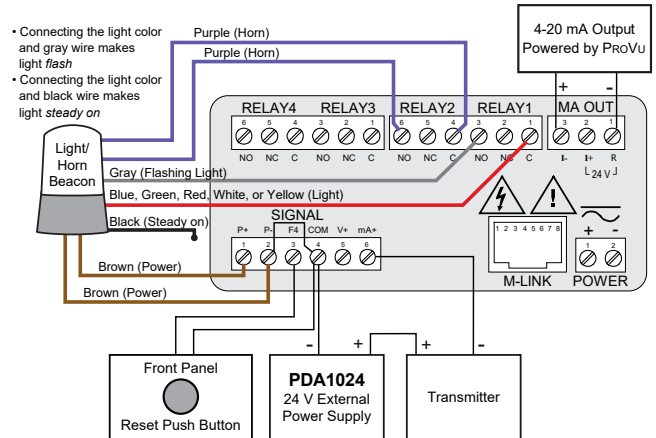

- Form C (SPDT) relays
- Two isolated supplies available even on 12/24 VDC input power models
- Removable terminal blocks
- 2 or 4 relays + isolated 4-20 mA output option
- Universal 85-265 VAC or 12/24 VDC input power
- Voltage or current inputs
- No jumpers needed for V/mA input selection
- M-Link for adding expansion modules
- Digital input (F4)

Complete Product Line of Displays and Controllers IN ALL SHAPES, SIZES & LOCATIONS



Big, Bright Displays For Indoor or Outdoor in Bright Sunlight



Large Dual-Line 6-Digit Display



24 VDC Transmitter Power Supply



MeterView Pro USB Programming Software



Universal 85-265 VAC or 12-24 VDC Input Power Options



4-20 mA, 0-10 V, Thermocouple, RTD, Strain Gauge, High Voltage, & Modbus Inputs



Up To Four 3 A Form C Relays (SPDT)



SP Ex CE IECEX

UL US

CE UL US

EXPLOSION-PROOF ProtEX-MAX Series

- NEMA 4X, IP68 Rated Enclosure
- CapTouch Through-Glass Buttons
- Operating Temperature of -55 to 65°C
- Worldwide Approvals

LARGE DISPLAYS Helios Series

- 1.8" Digits Readable From 100 Feet
- NEMA 4X, IP65 Rated Enclosure
- Operating Temperature of -40 to 65°C
- Now UL and C-UL Approved!

PANEL METERS ProVu Series

- NEMA 4X, IP65 Rated Front
- Programmable Function Keys
- UL, C-UL, and CE Approvals
- 1/8 DIN Size

Go to PREDIG.COM for details on ProVu, ProtEX-MAX and Helios Series Meters

No More Sun Glare On Your Panel Meter Display!

NEW PDA18DINSH Sun Hood

The PDA18DINSH Sun Hood improves the readability of 1/8 DIN digital panel meters when they are mounted in direct sunlight by shading the instrument from the sun.

The Sun Hood is made from 18 gauge 316 stainless steel and mounts between the 1/8 DIN digital panel meter and the panel. In addition, a gasket is provided that installs between the Sun Hood and the panel to provide a NEMA 4X seal to the panel. The whole assembly is held in place by the panel meter's mounting brackets.

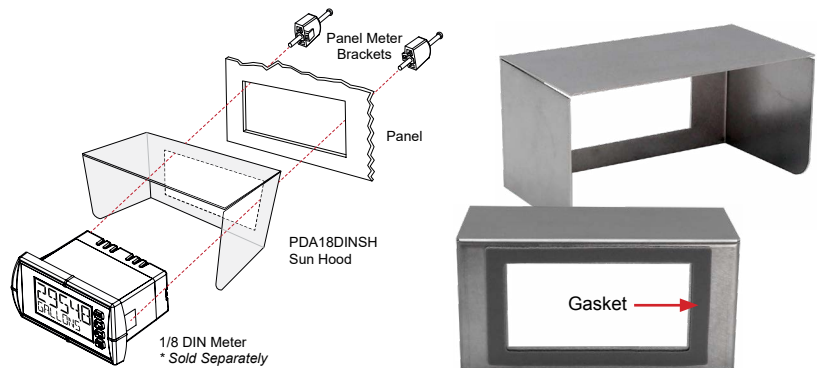

- Provides Shade for 1/8 DIN Digital Panel Meters
- Made from 18 Gauge 316 Stainless Steel
- Easy Mounting Requires no Drilled Holes in the Panel
- Includes Gasket to Maintain NEMA 4X Seal

SPECIFICATIONS

Model	PDA18DINSH
Material	18 gauge 316 stainless steel
Overall	2.99" x 5.68" x 2.99" (H x W x D)
Dimensions	(75 mm x 144 mm x 75 mm)
Weight	0.9 lb (0.4 kg)
Gasket Material	Silicone Foam

DIMENSIONS

Units: Inches (mm)

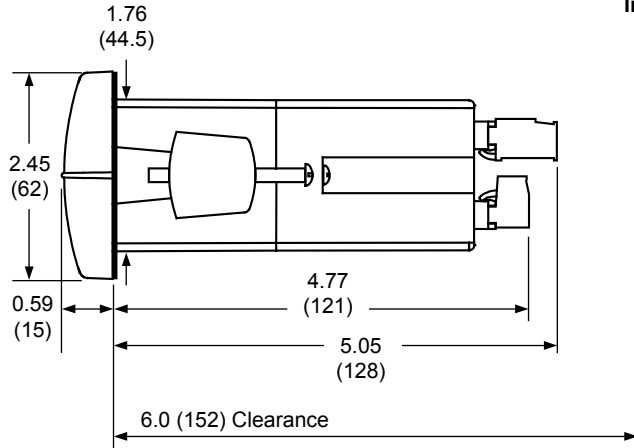

Side View

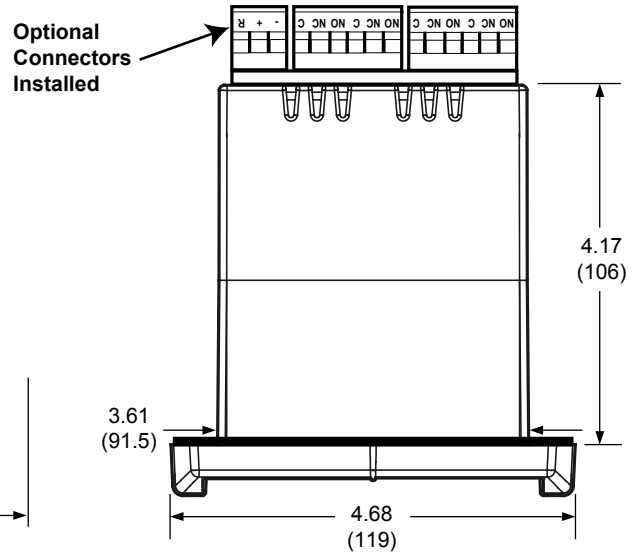

Top View

Notes:

1. Panel cutout required: 1.772" x 3.622" (45 mm x 92 mm)
2. Panel thickness: 0.040 - 0.250" (1.0 mm - 6.4 mm)
3. Mounting brackets lock in place for easy mounting
4. Clearance: Allow 6" (152 mm) behind the panel



Download free 3-D CAD files of these instruments to simplify your drawings!

predig.com/documentation-cad

CONNECTIONS

- Form C (SPDT) relays
- Two isolated supplies available even on 12/24 VDC input power models
- Removable terminal blocks
- 2 or 4 relays + isolated 4-20 mA output option

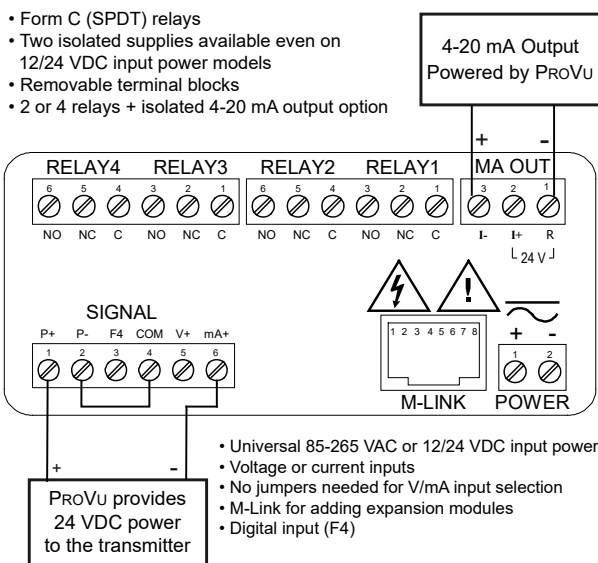

- Universal 85-265 VAC or 12/24 VDC input power
- Voltage or current inputs
- No jumpers needed for V/mA input selection
- M-Link for adding expansion modules
- Digital input (F4)

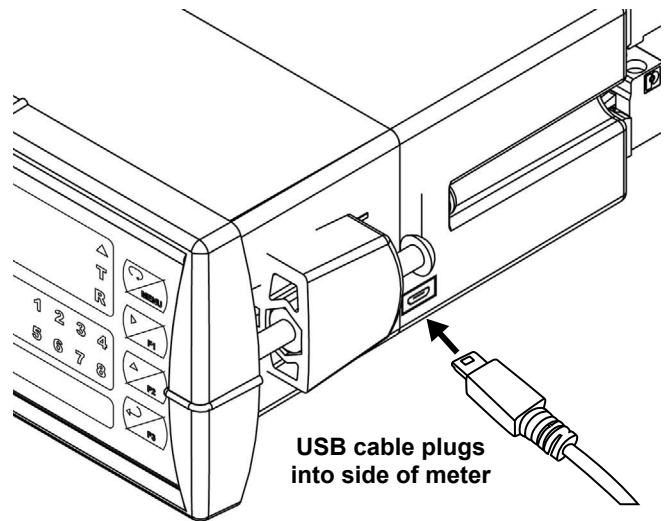

Click here to watch video on how to connect a 2-wire transmitter to a ProVu

SPECIFICATIONS

Except where noted all specifications apply to operation at +25°C.

General

Display	Line 1: 0.60" (15 mm) high, red LEDs Line 2: 0.46" (12 mm) high, red LEDs 6 digits each (-99999 to 999999), with lead zero blanking
Display Intensity	Eight user selectable intensity levels. Default value is six.
Display Update Rate	5/second (200 ms)
Overrange	Display flashes 999999
Underrange	Display flashes -99999
Display Assignment	Display Line 1: PV1, PV2, PCT, PV & units, gross weight, net & gross weight, max/min, max & min, set points, or Modbus input. Display Line 2: Same as Display Line 1; plus units, tag or turned off.
Programming Methods	Four front panel buttons, digital inputs, PC and MeterView Pro software, or Modbus registers.
Noise Filter	Programmable from 2 to 199 (0 will disable filter)
Filter Bypass	Programmable from 0.1 to 99.9% of calibrated span
Recalibration	All ranges are calibrated at the factory. Recalibration is recommended at least every 12 months.
Max/Min Display	Max/min readings reached by the process are stored until reset by the user or until power to the meter is turned off.
Rounding	Select 1, 2, 5, 10, 20, 50, or 100 (e.g. rounding = 10, value = 123.45, display = 123.50).
Tare	Tare function zeros out the meter to remove the for weight of a container. Tare function can be assigned to a function key, F4 terminal, or a digital input.
Password	Three programmable passwords restrict modification of programmed settings.
Non-Volatile Memory	All programmed settings are stored in non-volatile memory for a minimum of ten years if power is lost.
Power Options	85-265 VAC 50/60 Hz; 90-265 VDC, 20 W max; 12-24 VDC, 12-24 VAC, 15 W max. Powered over USB for configuration only.
Fuse	Required external fuse: UL Recognized, 5 A max, slow blow; up to 6 meters may share one 5 A fuse
Normal Mode Rejection	Greater than 60 dB at 50/60 Hz
Isolation	4 kV input/output-to-power line 500 V input-to-output or output-to-P+ supply
Overvoltage Category	Installation Overvoltage Category II: Local level with smaller transient overvoltages than Installation Overvoltage Category III.

Environmental	Operating temperature range: -40 to 65°C (-40 to 149°F) Storage temperature range: -40 to 85°C (-40 to 185°F) Relative humidity: 0 to 90% non-condensing
Connections	Removable screw terminal blocks accept 12 to 22 AWG wire, RJ45 for external relays, digital I/O, and serial communication adapters.
Enclosure	1/8 DIN, high impact plastic, UL 94V-0, color: black
Front Panel	NEMA 4X, IP65
Mounting	1/8 DIN panel cutout required: 3.622" x 1.772" (92 mm x 45 mm) Two panel mounting bracket assemblies are provided.
Tightening Torque	Screw terminal connectors: 5 lb-in (0.56 Nm)
Overall Dimensions	4.68" x 2.45" x 5.64" (119 mm x 62 mm x 143 mm) (W x H x D)
Weight	9.5 oz (269 g)
Warranty	3 years parts & labor. See Warranty Information and Terms & Conditions on www.predig.com for complete details.

Process Input

Inputs	Field selectable: 0-20 mA, 4-20 mA ±10 V (0-5 V, 1-5 V, 0-10 V) Modbus PV (Slave)
Isolated Transmitter Power Supply	Terminals P+ & P-: 24 VDC ±10%. All models selectable for 24, 10, or 5 VDC supply (internal jumper J4). 85-265 VAC models rated @ 200 mA max, 12-24 VDC powered models rated @ 100 mA max. 5 & 10 VDC supply rated @ 50 mA max. Refer to Transmitter Supply Voltage Selection (P+, P-) on page 17. When the Light/Horn is powered by the transmitter power supply, see MOD-LH Light/ Horn's transmitter power supply specification on page 28 for additional details. Light/Horn power not available for 5 or 10 VDC supplies.
Accuracy	±0.03% of calibrated span ±1 count, square root & programmable exponent accuracy range: 10-100% of calibrated span
Temperature Drift	0.005% of calibrated span/°C max from 0 to 65°C ambient, 0.01% of calibrated span/°C max from -40 to 0°C ambient
Input Signal Conditioning	Linear, square root, programmable exponent, or round horizontal tank volume calculation
Multi-Point Linearization	2 to 32 points for PV or PV1 2 to 8 points for PV2 (Dual-scale Level feature)
Programmable Exponent	User selectable from 1.0001 to 2.9999 for open channel flow

Round Horizontal Tank	Diameter & Length: 999.999 inch or cm calculates volume in gallons or liters respectively.	
Low-Flow Cutoff	0.1 to 999,999 (0 disables cutoff function). Point below at which display always shows zero.	
Decimal Point	Up to five decimal places or none: <i>dddddd, dddddd, dddd, ddd, dd, or dddddd</i>	
Calibration Range	Input Range	Minimum Span Input 1 & 2
	4-20 mA ±10 V	0.15 mA 0.10 V
	An error message will appear if the input 1 and input 2 signals are too close together.	
Input Impedance	Voltage ranges: greater than 500 kΩ Current ranges: 50 - 100 Ω (depending on internal resettable fuse impedance)	
Input Overload	Current input protected by an internal resettable fuse, 30 VDC max. Fuse resets automatically after fault is removed.	
HART Transparency	The meter does not interfere with existing HART communications; it displays the 4-20 mA primary variable and it allows the HART communications to pass through without interruption. The meter is not affected if a HART communicator is connected to the loop. The meter does not display secondary HART variables.	

Relays

Rating	2 or 4 SPDT (Form C) internal and/or 4 SPST (Form A) external; rated 3 A @ 30 VDC and 125/250 VAC resistive load; 1/14 HP (≈ 50 W) @ 125/250 VAC for inductive loads
Noise Suppression	Noise suppression is recommended for each relay contact switching inductive loads.
Deadband	0-100% of span, user programmable
High or Low Alarm	User may program any alarm for high or low trip point. Unused alarm LEDs and relays may be disabled (turn off).
Relay Operation	Automatic (non-latching), latching (requires manual acknowledge) with/without clear, sampling (based on time), pump alternation control (2 to 8 relays), Off (disable unused relays and enable interlock feature, manual on/off control mode).
Relay Reset (Acknowledge)	User selectable via front panel buttons or digital inputs. <ol style="list-style-type: none"> Automatic reset only (non-latching), when input passes the reset point. Automatic + manual reset at any time (non-latching). Manual reset only, at any time (latching). Manual reset only after alarm condition has cleared (latching). <p><i>Note: Front panel button or digital input may be assigned to acknowledge relays programmed for manual reset.</i></p>

Time Delay	0 to 999.9 seconds, on & off relay time delays. Programmable and independent for each relay
Fail-Safe Operation	Programmable and independent for each relay. <i>Note: Relay coil is energized in non-alarm condition. In case of power failure, relay will go to alarm state.</i>
Auto Initialization	When power is applied to the meter, relays will reflect the state of the input to the meter
Additional Relays	An external module, model PDA1004 , is available to add 4 SPST 3 A relays to the meter.

Isolated 4-20 mA Transmitter Output

Output Source	Process variable (PV), max, min, set points 1-8, Modbus input, or manual control mode		
Scaling Range	1.000 to 23.000 mA for any display range		
Calibration	Factory calibrated: 4.000 to 20.000 = 4-20 mA output		
Analog Out Programming	23.000 mA maximum for all parameters: Overrange, underrange, max, min, and break		
Accuracy	± 0.1% of span ± 0.004 mA		
Temperature Drift	0.4 μA/°C max from 0 to 65°C ambient, 0.8 μA/°C max from -40 to 0°C ambient <i>Note: Analog output drift is separate from input drift.</i>		
Isolated Transmitter Power Supply	Terminals I+ & R: 24 VDC ±10%. May be used to power the 4-20 mA output or other devices. All models rated @ 40 mA max.		
External Loop Power Supply	35 VDC maximum		
Output Loop Resistance	Power supply	Minimum	Maximum
	24 VDC	10 Ω	700 Ω
	35 VDC (external)	100 Ω	1200 Ω
Additional 4-20 mA Outputs	The PD659-1MA-2MA can split the optional 4-20 mA output into two isolated 4-20 mA outputs		
0-10 VDC Output	The PD659-1MA-1V can convert the optional 4-20 mA output to a 0-10 VDC output		

USB Connection

Function	Programming only
Compatibility	USB 2.0 Standard, Compliant
Connector Type	Micro-B receptacle
Cable	USB A Male to Micro-B Cable
Driver	Microsoft® Windows® 7/1/110
Power	USB port provides power to the meter. DO NOT apply AC or DC power to the meter while the USB port is in use.

On-Board Digital Input (F4)

Function	Remote operation of front-panel buttons, acknowledge/reset relays, reset max/min values.
Contacts	3.3 VDC on contact. Connect normally open contacts across F4 to COM.
Logic Levels	Logic High: 3 to 5 VDC Logic Low: 0 to 1.25 VDC
Additional I/O	Up to 2 external modules, model PDA1044 with 4 digital inputs and 4 digital outputs each can be added.

Modbus RTU Serial Communications

Slave Id	1 – 247 (Meter address)
Baud Rate	300 – 19,200 bps
Transmit Time Delay	Programmable between 0 and 199 ms
Data	8 bit (1 start bit, 1 or 2 stop bits)
Parity	Even, Odd, or None with 1 or 2 stop bits
Byte-To-Byte Timeout	0.01 – 2.54 second
Turn Around Delay	Less than 2 ms (fixed)

Note: Refer to the PROVu Modbus Register Tables located at www.predig.com for details.

MeterView Pro Software

Availability	Download directly from meter or from www.predig.com/download_software
System Requirements	Microsoft® Windows® 7/10/11
Communications	USB 2.0 (for programming only) (Standard USB A to Micro USB B) RS-232 adapter, RS-485 adapter and RS-485 to USB converter (programming, monitoring, and data logging)
Configuration	Configure meters one at a time
Power	USB port provides power to the meter. DO NOT apply AC or DC power to the meter while the USB port is in use.

Digital I/O Expansion Module

Channels	4 digital inputs & 4 digital outputs per module
System	Up to 2 modules for a total of 8 inputs & 8 outputs
Digital Input Logic	High: 3 to 5 VDC Low: 0 to 1.25 VDC
Digital Output Logic	High: 3.1 to 3.3 VDC Low: 0 to 0.4 VDC
Source Current	10 mA maximum
Sink Current	1.5 mA minimum
+5 V Terminal	To be used as pull-up for digital inputs only.

4-Relay Expansion Module

Relays	Four Form A (SPST) rated 3 A @ 30 VDC and 125/250 VAC resistive load; 1/14 HP (≈ 50 watts) @ 125/250 VAC for inductive loads.
---------------	---

MOD-LH Light/Horn

Light Colors	MOD-LHRB1: Red MOD-LHGB1: Green MOD-LHYB1: Yellow MOD-LHBB1: Blue MOD-LHWB1: White MOD-LH5CB1: User selectable: red, green, yellow, blue, white MOD-LH3CB1-RYG: 1 layer each of red, yellow, green (consult factory for other colors available)
Light Action	Can be wired to flash (not available on MOD-LH5CB1) or stay steady on
Light/Horn & Button Installation	When MOD-LH is ordered with an enclosure, the user performs installation and wiring of Light/Horn and Button in pre-drilled holes.
Horn	85 dB
Rating	IP 65
Light/Horn Independence	Light and horn can be controlled via separate relays
Power Requirement	No additional power required when wired to a ProVu meter. When mounted remote: 24 VDC
Transmitter Power Supply	The ProVu's internal transmitter power supply is capable of supplying 200 mA to power the transmitter and other devices such as the Light/Horn. The following table illustrates how much of this power is required to drive various Light/Horns. If more power is needed, then consider the PDA1024-01.

MOD-LH and MOD-LH5CB1 Models:

Color	Power Required	Color	Power Required
Red	17 mA	Blue	15 mA
Green	15 mA	White	42 mA
Yellow	23 mA	Horn	20 mA

Example: 17 mA (Red Light) + 20 mA (Horn) = 37 mA total current needed from the 200 mA supply. Available current = 163 mA

MOD-LH3LCB1-RYG:

Power Requirement for the horn and each color that is turned on:

Color	Power Required	Color	Power Required
Red	34 mA	Yellow	33 mA
Green	29 mA	Horn	38 mA

Example: 33 mA (Yellow Light) + 38 mA (Horn) = 71 mA total current needed from the 200 mA supply. Available current = 139 mA

Reset / Silence Button	NEMA 4X; may be wired to F4 terminal on PROVu. F3 front panel button can also be used to reset relays.
-------------------------------	--

Button Labels	The Light/Horn accessory comes with 9 pre-printed message labels the user can affix under the red button: RESET, BATCH, ACK, TARE, SILENCE, STOP, START, PAUSE, START/STOP
----------------------	--

Light/Horn Mounting Connection	M22
---------------------------------------	-----

Hole Sizes	Light/Horn: 0.875" (22 mm) Button: 0.630" (16 mm)
-------------------	--

Cable Length:	3.28 feet (1 meter)
----------------------	---------------------

Operating Temperature Range	-5 to 40°C (23 to 104°F)
------------------------------------	--------------------------

Compliance Information

Safety

UL & C-UL Listed	USA & Canada UL 508 Industrial Control Equipment
UL File Number	E160849
Front Panel	UL Type 4X, NEMA 4X, IP65; panel gasket provided
Low Voltage Directive	EN 61010-1 Safety requirements for measurement, control, and laboratory use

Electromagnetic Compatibility

Emissions	EN 55022 Class A ITE emissions requirements
Radiated Emissions	Class A
AC Mains Conducted Emissions	Class A
Immunity	EN 61326-1 Measurement, control, and laboratory equipment EN 61000-6-2 EMC heavy industrial generic immunity standard
RFI - Amplitude Modulated	80 -1000 MHz 10 V/m 80% AM (1 kHz) 1.4 - 2.0 GHz 3 V/m 80% AM (1 kHz) 2.0 - 2.7 GHz 1 V/m 80% AM (1 kHz)
Electrical Fast Transients	±2kV AC mains, ±1kV other
Electrostatic Discharge	±4kV contact, ±8kV air
RFI - Conducted	10V, 0.15-80 MHz, 1kHz 80% AM
AC Surge	±2kV Common, ±1kV Differential
Surge	1KV (CM)
Power-Frequency Magnetic Field	30 A/m 70%V for 0.5 period
Voltage Dips	40%V for 5 & 50 periods 70%V for 25 periods
Voltage Interruptions	<5%V for 250 periods

Note: Testing was conducted on meters installed through the covers of grounded metal enclosures with cable shields grounded at the point of entry representing installations designed to optimize EMC performance.

EU Declaration of Conformity

For shipments to the EU and UK, a Declaration of Conformity was printed and included with the product. For reference, a Declaration of Conformity is also available on our website www.predig.com/docs.

PD6000 ProVu Dual-Line 6-Digit Process Meter

ORDERING INFORMATION

ProVu PD6000 • Standard Models		
85-265 VAC Model	12-24 VDC Model	Options Installed
PD6000-6R0	PD6000-7R0	None
PD6000-6R2	PD6000-7R2	2 Relays
PD6000-6R3	PD6000-7R3	4-20 mA Output
PD6000-6R4	PD6000-7R4	4 Relays
PD6000-6R5	PD6000-7R5	2 Relays & 4-20 mA Output
PD6000-6R7	PD6000-7R7	4 Relays & 4-20 mA Output

Note: 24 V Transmitter power supply standard on all models.

ProVu PD6000 • SunBright Display Models		
85-265 VAC Model	12-24 VDC Model	Options Installed
PD6000-6H0	PD6000-7H0	None
PD6000-6H2	PD6000-7H2	2 Relays
PD6000-6H3	PD6000-7H3	4-20 mA Output
PD6000-6H4	PD6000-7H4	4 Relays
PD6000-6H5	PD6000-7H5	2 Relays & 4-20 mA Output
PD6000-6H7	PD6000-7H7	4 Relays & 4-20 mA Output

Note: 24 V Transmitter power supply standard on all models.

Accessories	
Model	Description
MOD-LHRB1	Red ⁽²⁾ Light/Horn and Button with Holes Drilled for Light/Horn and Button in Enclosure ⁽¹⁾
PDA-BUTTON1R	Button
PDA-LHR	Red ⁽²⁾ Light/Horn
PDA1002	DIN Rail Mounting Kit for Two Expansion Modules
PDA1004	4-Relay Expansion Module
PDA1024-01	24 VDC Power Supply for DIN Rail
PDA1044	4 Digital Inputs & 4 Digital Outputs Module
PDA1232	RS-232 Serial Adapter
PDA1485	RS-485 Serial Adapter
PDA18DINSH	Stainless Steel Sun Hood
PDA7485-I	RS-232 to RS-422/485 Isolated Converter
PDA8232-N	USB to RS-232 Non-Isolated Converter
PDA8485-I	USB to RS-422/485 Isolated Converter
PDX6901	Suppressor (snubber): 0.01 µF/470 Ω, 250 VAC

- The enclosure comes pre-drilled with holes for Light/Horn and Button to be installed by user. Meter / controller and enclosure are sold separately. The Light/Horn hole is located on the top in the back left corner of the enclosure and the button hole is centered on the front of the enclosure about an inch off the bottom of the door. For mounting in different locations, order items separately and drill holes and mount as desired.
- For other light color options see the MOD-LH Series manual (LIMMODLH).

ProVu Upgrade Cards	
Model	Description
PD1102	2 Relays
PD1103	4-20 mA Output ¹
PD1104	4 Relays
PD1105	2 Relays + 4-20 mA Output ¹
PD1107	4 Relays + 4-20 mA Output ¹

- Output calibration required by user.
- These upgrade cards are intended for customers who already have a meter and want to upgrade its functionality.

PDA2360 Series Control Stations	
Model	Description
PDA2360-E	Emergency Stop Button
PDA2361-A	1 Black Ack Button
PDA2361-Q	1 Black Silence Button
PDA2364-MRUE	4 Black Buttons: Menu, Right, Up, Enter

Your Local Distributor is:

Disclaimer

The information contained in this document is subject to change without notice. Precision Digital Corporation makes no representations or warranties with respect to the contents hereof, and specifically disclaims any implied warranties of merchantability or fitness for a particular purpose.

©2024 Precision Digital Corporation. All rights reserved.



WARNING
Cancer and Reproductive Harm - www.P65Warnings.ca.gov

LDS6000_M 03/24