

PROCESS & TEMPERATURE LIMIT CONTROLLERS

NOVA PD570 Series



- Thermocouple, RTD, & Process Input
- Universal Power Supply 100-240 VAC
- Latching Relay High or Low Limit Control
- 1 Latching Relay & 1 Alarm Relay
- Retransmitting 4-20 mA Output
- RS-485 Serial Communications Option
- Modbus® RTU/ASCII Communications
- Free Operating & Data Logging Software
- IP55 & IP65 Fronts
- 1/16 & 1/4 DIN Sizes
- 3 Year Warranty

OPERATING DISPLAYS

Nova Limit Controllers have dual four-digit LEDs and display the PV, limit set point, relay status, and limit operation information.

Operating Display Navigation

To access additional operational information without the need to enter the setup menus, simply press the **SET/ENT** button.



Main Operating Display

- Displays process variable
- Displays the limit set point
- **Over** LED indicates when over limit conditions exist
- **Out** LED indicates latching relay status
- **ALM** alarm status LED indicator



System Condition



Over Limit Timer



Max/Min Input Value

EASY SETUP & PROGRAMMING

All programming of a Nova Limit Controller is done through the front panel. No switches or jumpers are required.

Front Panel Buttons

- Hold the **RST** button for 3 seconds when the unit is not in over limit conditions to reset the latching limit relay.
- Press the **SET/ENT** button to confirm an entered value. Hold the button for 3 seconds to enter or exit the setup groups. Press the **SET/ENT** button to access the next parameter when in a setup group.
- Press the **Up** button to increase numerical values including the set point or scroll through parameter options and group menus.
- Press the **Down** button to decrease numerical values including the set point or scroll through parameter options and group menus.
- Press the **LEFT** button to move to the next digit during numerical value programming.

Setup Group Menus

For easy setup parameter navigation, all parameters are grouped by category. To access the group menus, press and hold the **SET/ENT** button for 3 seconds. Navigate through the group menus using the **UP** or **DOWN** buttons as shown. To enter a group menu to access setup parameters, press the **SET/ENT** button.

Button	PV Display	Group Definition
ENT	Pwd	Password
▲▼	G.Ctl	Control Group
▲▼	G.In	Input Group
▲▼	G.ALn	Alarm Group
▲▼	G.rEt	Retransmission Group
▲▼	G.Coñ*	Communications Group*

*This group menu appears only on models with the serial communication option.

Menu Password

To prevent unauthorized changes to key parameters, a user defined lockout password must be entered to access the group menus that are not commonly used during operation. Enter the password at the prompt when navigating the group menus by pressing the **SET/ENT** button. The default password is 0.

Easy to Use Menu Structure

Each setup parameter is located in an associated menu group.

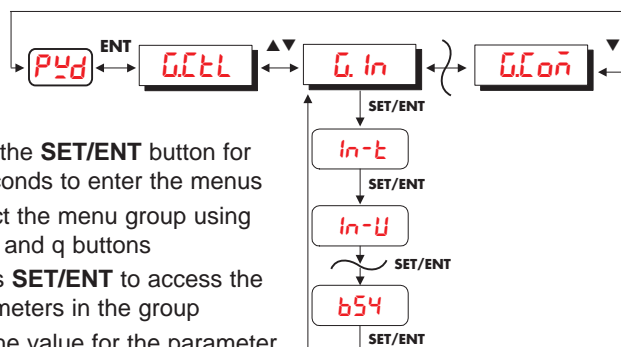

- Hold the **SET/ENT** button for 3 seconds to enter the menus
- Select the menu group using the p and q buttons
- Press **SET/ENT** to access the parameters in the group
- Set the value for the parameter, and use the **SET/ENT** button to select the next parameter
- Hold the **SET/ENT** button for 3 seconds to return to the operating display

For a complete list of setup parameters, their functions, and setting options, refer to the PD570 Series Instruction Manual.

PROCESS & TEMPERATURE INPUTS

Nova Controllers use a single universal input that accepts process and temperature inputs.

Thermocouple: J, K, T, E, R, B, S, L, N, U, W, Platine II

RTD: Pt100 (0.00385), JPt100 (0.00392)

Process: -10 to 20 mV, 0 to 100 mV
0.4 to 2 V, 1 to 5 V, 0 to 10 V
4 to 20 mA input with a resistor shunt

GENERAL FEATURES

The PD570 Series of Limit Controllers come equipped with a limit control latching relay, alarm relay, and a 4-20 mA retransmitting output. These standard features make the Limit Controller an excellent process monitoring tool. Serial communications for Modbus or PC monitoring software expands the Limit Controller's capability.

Powerful Relay Functionality

All PD570 Series Limit Controllers have a 3 A Form C (SPDT) latching relay for use in limit control functions. All PD570 Series controllers also have a 1 A Form A (SPST) alarm relay.

- High or Low PV Limit Latching Relay
- Forward and Reverse (Fail-Safe) Latching and Alarm Relays
- High/Low and Set Point Deviation Alarms
- Fail-Safe and Standby Alarms
- Relay Delays and Reset Deadbands

Latching Relay Over Limit Control

When an over limit condition occurs, the latching relay will trigger. The relay must be reset manually and can only be reset once the input returns to normal operating conditions as established by the set point and programmable hysteresis.

4-20 mA Retransmitting Output

A 4-20 mA powered output is standard on all PD570 Series models. The output can be programmed to transmit over any input scale for any input type or based on the set point value.

Transmitter Loop Power Supply

The 4-20 mA retransmitting output may be configured to provide a 14 to 18 VDC @ 20 mA transmitter power supply.

Input Bias Adjustment

Up to five bias points set to specific input values can be used to provide precise offset adjustments through 4 bias zones. The controller will use the offset to create a smooth input value curve leading up to the bias points.

Max/Min Input Readings

Easily view the maximum or minimum input value reached during over limit conditions without entering the setup menus.

Display Over Limit Time

A timer to track the over limit times in minutes and seconds or hours and minutes is easily displayed from the operating menu.

Serial Communications & Adapters

Nova controllers with the serial communications option can be used for data acquisition or Modbus communication (RTU and ASCII). Nova controllers transmit via RS-485. The PDA7485 RS-232 to RS-485 and PDA8485 USB to RS-485 converters are available for use with the Nova Multi-Monitoring software or other PC applications.

NOVA PC SOFTWARE

Any Nova Controller with the serial communication option can be configured to interface with the Nova Multi-Monitoring PC software. Up to 30 controllers can be monitored and operated, and each can use independent data logging.

- Easy to Set Up and Use
- Connect up to 30 Nova Controllers
- View PV and Alarm Status
- Log, View, and Save Data in Spreadsheet Files
- Free Download from www.predig.com

Specifications

System Requirements: Windows® 95\98\ME\2000\XP

Communications: An RS-232 to RS-485 or USB to RS-485 converter may be used for communication with a PC and Nova Multi-Monitoring Software.

Number of Units: Up to 30 Nova Controllers

Baud Rate: 9,600 to 19,200 bps

Data Logging: Graph and save data as .hdr format. Each controller saves graphs independently. Data exportable in spreadsheet format.

Logging Interval: 1 second to 24 hours

Simultaneous Monitoring

Simultaneously monitor up to 30 Nova Controllers and view the PV, SP, and alarm status for all connected controllers. The main view screen also displays the basic model numbers of all connected units. Any series of Nova Controllers with the serial communication option may be monitored with this software.



Simultaneously View Up to 30 Nova Controllers

Remote Set Point Control and Indication

A detailed operation screen for each controller indicates the model number of the controller, the PV, SP, alarm conditions, high or low PV input, and the over limit condition timer. The set point, direction of operation (high or low limit control) and startup relay condition can all be set through this screen.

Data Acquisition

PV and SP data can be logged independently for each unit, and each can have a distinct file name, save location, and logging interval. This data can be graphed using the Data Viewer for quick and clear analysis. Logged data can be exported into spreadsheet format.

Download the Nova Multi-Monitoring Software Free at www.predig.com

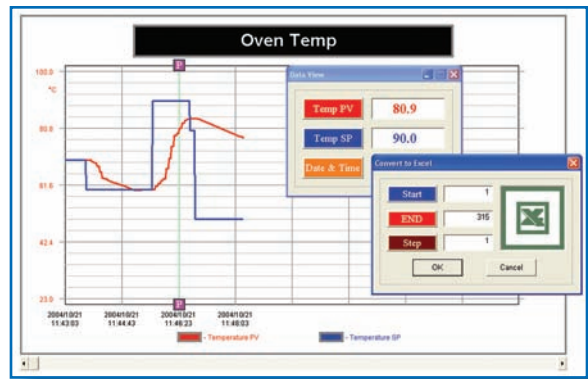

View Logged Data Graphs and Export Data

DIMENSIONS AND PANEL CUTOUTS

Units: inches (mm)

PD570

1/16 DIN (48 x 48)

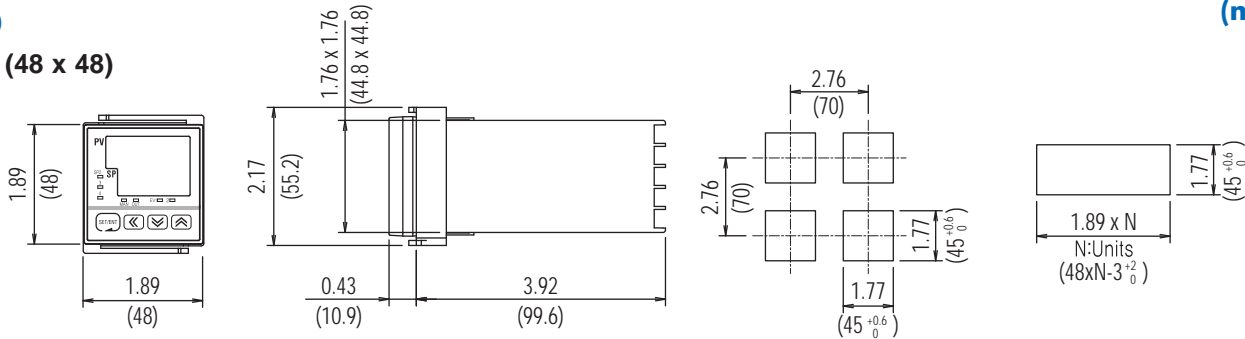

PD578

1/4 DIN (96 x 96)

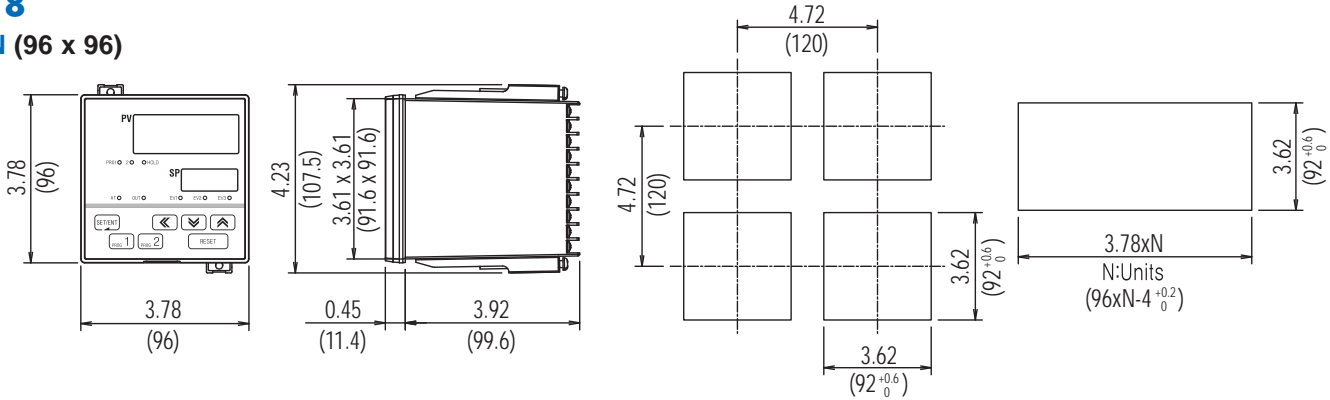

MODEL NUMBER GUIDE

The following guide describes the possible PD570 Series Nova Process & Temperature Limit Controller model numbers. Refer to the price list for the complete list of models and accessories.

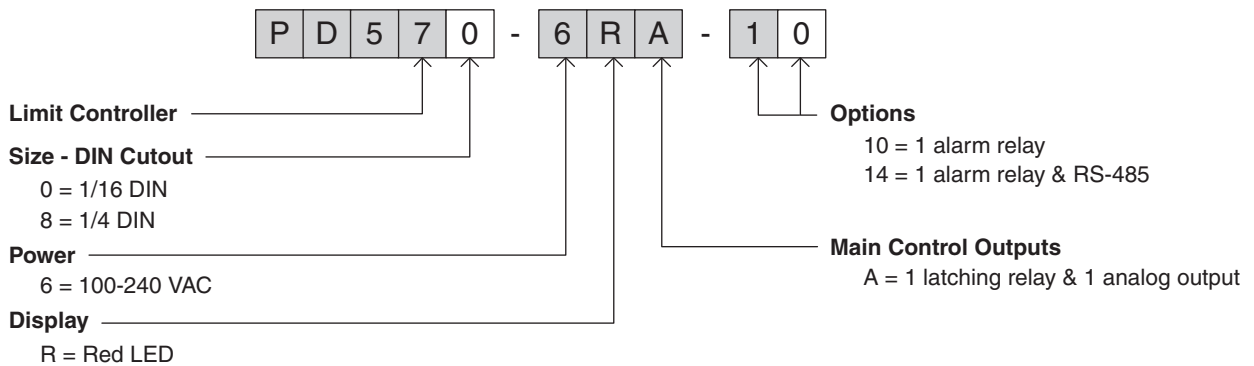

CONNECTIONS

PD570

: Options

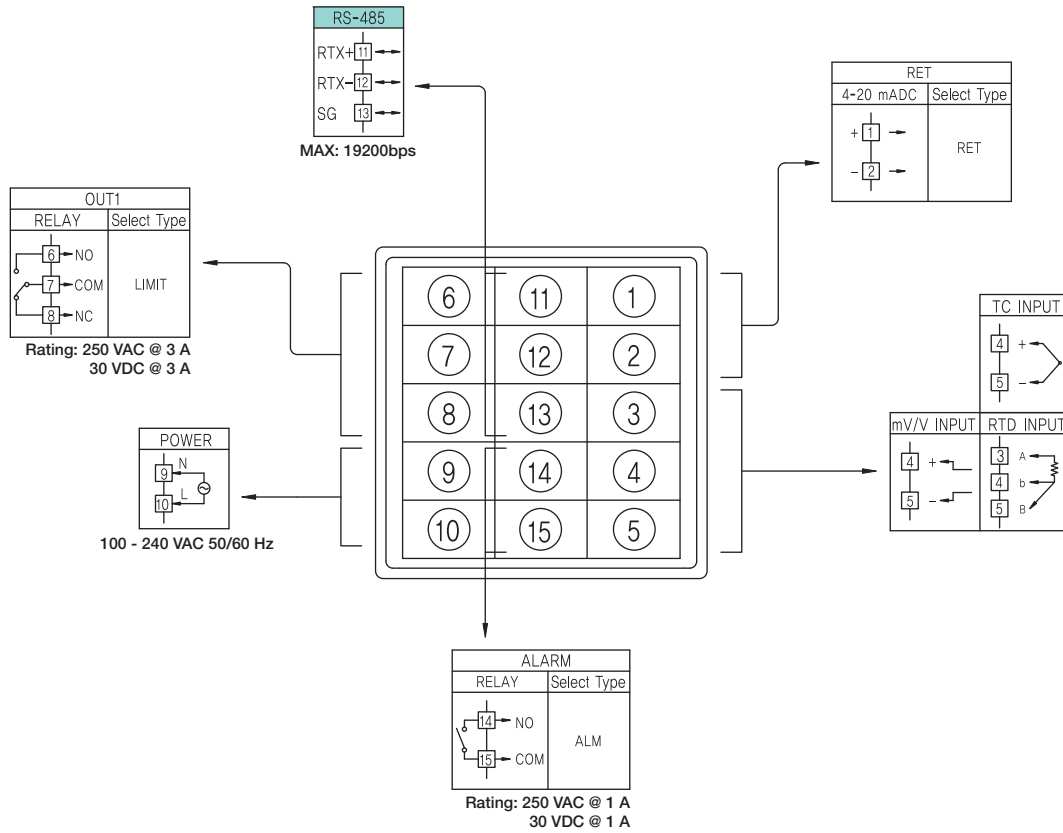

PD578

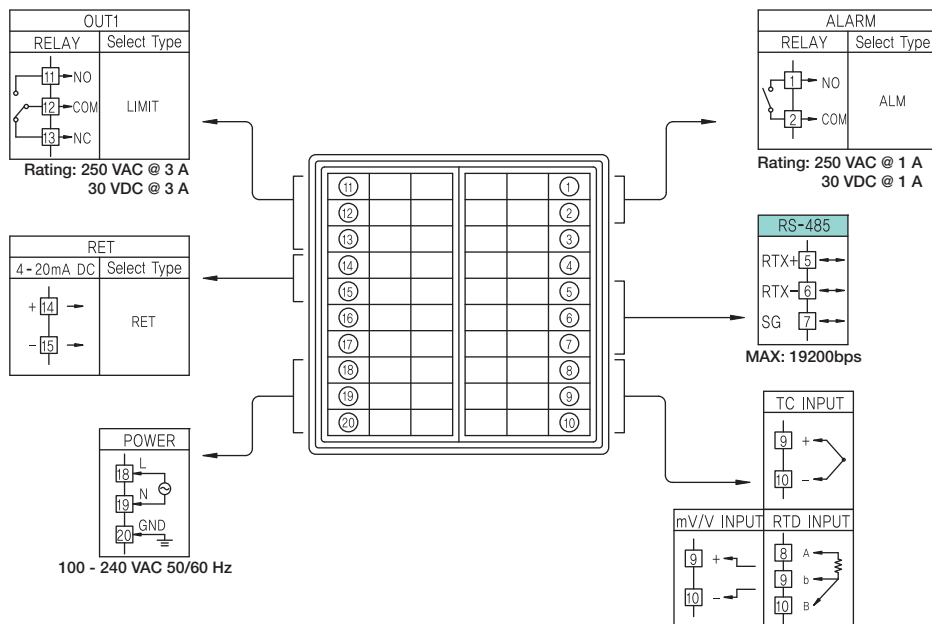

SPECIFICATIONS

Except where noted all specifications apply to operation at +25°C.

General

Display: Dual 4 digits, red LED, -1999 to 9999

DIN Sizes	PV Display Inch (mm)	SP Display Inch (mm)	Weight oz (g)
1/16	0.45 (11.3)	0.37 (9.5)	7.0 (198)
1/4	0.81 (20.5)	0.43 (11.0)	13.9 (394)

Front Panel: Panel gasket provided

1/16 DIN: IP65

1/4 DIN: IP55

Programming Methods: Four front panel buttons and Modbus

Number of Set Points: 1 limit control

Noise Filter: Programmable 1 to 120 seconds, or off

Display Update Rate: 4/second

Max/Min Display: Stored until reset by user or controller is turned off.

Password: Restricts modification of programmed settings.

Non-Volatile Memory: Settings stored for a minimum of 10 years.

Power: 100-240 VAC, 50/60 Hz, 10 W

Required Fuse: UL Recognized, 1 A, 250 V, slow-blow

Isolation: 2300 V input/output-to-power line; 4 kV relay output-to-input/output/power line.

Operating Temperature: 10 to 50°C

Storage Temperature: -40 to 85°C

Relative Humidity: 20 to 90% non-condensing

Enclosure: 1/16, & 1/4 DIN available; impact-resistant plastic; color: black

Approvals: UL & C-UL Recognized, CE Compliant

UL File Number: E244207; Process Control Equipment

Warranty: 3 years parts & labor

Extended Warranty: 1 or 2 years, refer to Price List for details.

Temperature Inputs

Inputs: Factory calibrated, field selectable: J, K, T, E, B, R, S, L, U, N, W, and Platinel II thermocouples and 100 Ω platinum RTD (0.00385 or 0.00392 curve)

Cold Junction Reference: Automatic or off

Offset Adjustment: Four programmable input bias zones

Sensor Break: Up or down scale, user selectable; display reads S.OPN;

Type	Range (°C)	Range (°F)	Accuracy*	
Thermocouple	K1	-200 to 1370	-300 to 2500	
	K2	-199.9 to 999.9	0 to 2300	
	J	-199.9 to 999.9	-300 to 2300	>0°C: ±0.1% FS ±1 count <0°C: ±0.2% FS ±1 count
	T	-199.9 to 400.0	-300 to 750	
	E	-199.9 to 999.9	-300 to 1800	
	B	0 to 1800	32 to 3300	>400°C: ±0.15% FS ±1 count <400°C: ±5% FS ±1 count
	R	0 to 1700	32 to 3100	±0.15% FS ±1 count
	S	0 to 1700	32 to 3100	±0.15% FS ±1 count
	L	-199.9 to 900.0	-300 to 1600	>0°C: ±0.1% FS ±1 count <0°C: ±0.2% FS ±1 count
	U	-199.9 to 400.0	-300 to 750	>0°C: ±0.1% FS ±1 count <0°C: ±0.25% FS ±1 count
RTD	N	-200 to 1300	-300 to 2400	>0°C: ±0.1% FS ±1 count <0°C: ±0.25% FS ±1 count
	W	0 to 2300	32 to 4200	±0.2% FS ±1 count
	Platinel II	0 to 1390	32 to 2500	±0.1% FS ±1 count
	PtA	-199.9 to 850.0	-300 to 1560	±0.1% FS ±1 count
	PtB	-199.9 to 500.0	-199.9 to 999.9	±0.1% FS ±1 count
	PtC	-19.99 to 99.99	-4.0 to 212.0	±0.2% FS ±1 count
JPtA	-199.9 to 500.0	-199.9 to 999.9	±0.1% FS ±1 count	
JPtB	-150.0 to 150.0	-199.9 to 300.0	±0.1% FS ±1 count	

*Performance within recommended operating conditions (10 to 50 °C, 20 to 90% RH)

Process Inputs

Inputs: Field selectable: 0.4 to 2.0 V, 1 to 5 V, 0 to 10 V, -10 to 20 mV, 0 to 100 mV. 4-20 mA input requires 100 Ω resistor connected across input terminals (order P/N: PDX-RES1).

Accuracy: ±0.1% FS ±1 count

Decimal Point: Up to 3 decimals: 9.999, 99.99, 999.9, or 9999

Calibration: All inputs are calibrated at the factory

Scale Range: User programmable over entire range

Transmitter Supply: 14 to 18 VDC @ 20 mA; available instead of retransmitting analog output; selection is made through the front panel.

Limit Control Relay and Indicators

Ratings: Latching, 1 Form C (SPDT); rated 3 A @ 30 VDC or 3 A @ 250 VAC resistive load

Relay Operation: User may select high or low limit operation, forward or reverse (fail-safe) mode.

Reverse Operation (Fail-Safe): Programmable; relay coil is energized in non-alarm condition. In case of power failure, relay will go to alarm state.

Forward Operation: Relay coil is energized in alarm condition. In case of power failure, relay will go to non-alarm state.

Hysteresis: 0-10% FS, user selectable; manual reset allowed after condition has been corrected.

Out LED: Relay status indicator. LED is on when relay is de-energized (during over limit conditions in reverse operation).

Over Limit LED: Over LED is on when system is in over limit condition. LED will go off once system returns to normal condition.

Over Limit Timer Display: Time stored since last occurrence of over limit condition or until controller is turned off.

Alarm Relay

Ratings: 1 Form A (SPST); rated 1 A @ 30 VDC or 1 A @ 250 VAC resistive load

High/Low Alarm: User may program alarm for absolute value, high or low operation, forward or reverse (fail-safe) mode.

Deviation Alarm: User may program relay for high, low, or high/low range deviation alarm, forward or reverse (fail-safe) mode.

Alarm Deadband: 0-100% FS, user selectable

Alarm Delay: 0 to 99 minutes and 59 seconds

Reverse Operation (Fail-Safe): Programmable; relay coil is energized in non-alarm condition. In case of power failure, relay will go to alarm state.

Forward Operation: Relay coil is energized in alarm condition. In case of power failure, relay will go to non-alarm state.

Auto Alarm Initialization: Normal and standby operation. Normal alarm will reflect the state of the input to the controller at all times. Standby alarm will not trigger if the change to alarm state is a result of power up cycle, set point change, or alarm configuration change.

4-20 mA Retransmitting Output

Scaling Range: 4-20 mA output can be scaled for any display

Accuracy: ±0.1% FS

Power: Internally powered 4-20 mA output

Isolation: 500 V input-to-output

Output Loop Resistance: 600 Ω max

Serial Communications

Compatibility: EIA-485

Protocols: PC, Modbus (ASCII, RTU)

Address: 1 to 99 (Max 31 units connected)

Baud Rate: 600 to 19,200 bps

Transmit Time Delay: 0 to 100 ms

Data: 7 or 8 bit, automatic when using Modbus protocol

Stop Bit: 1 or 2

Parity: None, even, or odd